



Sorensen
SG Series
IEEE 488.2/RS232 and
Ethernet Options
Programming Manual

About AMETEK

AMETEK Programmable Power, Inc., a Division of AMETEK, Inc., is a global leader in the design and manufacture of precision, programmable power supplies for R&D, test and measurement, process control, power bus simulation and power conditioning applications across diverse industrial segments. From bench top supplies to rack-mounted industrial power subsystems, AMETEK Programmable Power is the proud manufacturer of Elgar, Sorensen, California Instruments and Power Ten brand power supplies.

AMETEK, Inc. is a leading global manufacturer of electronic instruments and electromechanical devices with annualized sales of \$2.5 billion. The Company has over 11,000 colleagues working at more than 80 manufacturing facilities and more than 80 sales and service centers in the United States and around the world.

Trademarks

AMETEK is a registered trademark of AMETEK, Inc. Sorensen is a trademark owned by AMETEK, Inc. Other trademarks, registered trademarks, and product names are the property of their respective owners and are used herein for identification purposes only.

Notice of Copyright

SG Series IEEE 488.2/RS232 and Ethernet Options Programming Manual © 2004-2008 AMETEK Programmable Power, Inc. All rights reserved.

Exclusion for Documentation

UNLESS SPECIFICALLY AGREED TO IN WRITING, AMETEK PROGRAMMABLE POWER, INC. ("AMETEK"):

- (a) MAKES NO WARRANTY AS TO THE ACCURACY, SUFFICIENCY OR SUITABILITY OF ANY TECHNICAL OR OTHER INFORMATION PROVIDED IN ITS MANUALS OR OTHER DOCUMENTATION.
- (b) ASSUMES NO RESPONSIBILITY OR LIABILITY FOR LOSSES, DAMAGES, COSTS OR EXPENSES, WHETHER SPECIAL, DIRECT, INDIRECT, CONSEQUENTIAL OR INCIDENTAL, WHICH MIGHT ARISE OUT OF THE USE OF SUCH INFORMATION. THE USE OF ANY SUCH INFORMATION WILL BE ENTIRELY AT THE USER'S RISK, AND
- (c) REMINDS YOU THAT IF THIS MANUAL IS IN ANY LANGUAGE OTHER THAN ENGLISH, ALTHOUGH STEPS HAVE BEEN TAKEN TO MAINTAIN THE ACCURACY OF THE TRANSLATION, THE ACCURACY CANNOT BE GUARANTEED. APPROVED AMETEK CONTENT IS CONTAINED WITH THE ENGLISH LANGUAGE VERSION, WHICH IS POSTED AT WWW.PROGRAMMABLEPOWER.COM.

Date and Revision

December 2008 Revision F

Part Number

M550129-03



Contact Information

Telephone: 800 733 5427 (toll free in North America)
858 450 0085 (direct)
Fax: 858 458 0267
Email: sales@programmablepower.com
service@programmablepower.com
Web: www.programmablepower.com

This page intentionally left blank.

Important Safety Instructions

Before applying power to the system, verify that your product is configured properly for your particular application.

	Hazardous voltages may be present when covers are removed. Qualified personnel must use extreme caution when servicing this equipment. Circuit boards, test points, and output voltages also may be floating above (below) chassis ground.
	The equipment used contains ESD sensitive parts. When installing equipment, follow ESD Safety Procedures. Electrostatic discharges might cause damage to the equipment.

Only *qualified personnel* who deal with attendant hazards in power supplies, are allowed to perform installation and servicing.

Ensure that the AC power line ground is connected properly to the Power Rack input connector or chassis. Similarly, other power ground lines including those to application and maintenance equipment *must* be grounded properly for both personnel and equipment safety.

Always ensure that facility AC input power is de-energized prior to connecting or disconnecting any cable.

In normal operation, the operator does not have access to hazardous voltages within the chassis. However, depending on the user's application configuration, **HIGH VOLTAGES HAZARDOUS TO HUMAN SAFETY** may be normally generated on the output terminals. The customer/user must ensure that the output power lines are labeled properly as to the safety hazards and that any inadvertent contact with hazardous voltages is eliminated.

Guard against risks of electrical shock during open cover checks by not touching any portion of the electrical circuits. Even when power is off, capacitors may retain an electrical charge. Use safety glasses during open cover checks to avoid personal injury by any sudden component failure.

Neither AMETEK Programmable Power Inc., San Diego, California, USA, nor any of the subsidiary sales organizations can accept any responsibility for personnel, material or inconsequential injury, loss or damage that results from improper use of the equipment and accessories.

SAFETY SYMBOLS

 **WARNING**
Risk of Electrical Shock

 **CAUTION**
Refer to Accompanying Documents

 Off (Supply)

 Direct Current (DC)

 Standby (Supply)

 Alternating Current (AC)

 On (Supply)

 Three-Phase Alternating Current

 Protective Conductor Terminal

 Earth (Ground) Terminal

 Fuse

 Chassis Ground

This page intentionally left blank.

Product Family: SG Series IEEE 488.2/RS232 and Ethernet Options

Warranty Period: Five Years

WARRANTY TERMS

AMETEK Programmable Power, Inc. ("AMETEK"), provides this written warranty covering the Product stated above, and if the Buyer discovers and notifies AMETEK in writing of any defect in material or workmanship within the applicable warranty period stated above, then AMETEK may, at its option: repair or replace the Product; or issue a credit note for the defective Product; or provide the Buyer with replacement parts for the Product.

The Buyer will, at its expense, return the defective Product or parts thereof to AMETEK in accordance with the return procedure specified below. AMETEK will, at its expense, deliver the repaired or replaced Product or parts to the Buyer. Any warranty of AMETEK will not apply if the Buyer is in default under the Purchase Order Agreement or where the Product or any part thereof:

- is damaged by misuse, accident, negligence or failure to maintain the same as specified or required by AMETEK;
- is damaged by modifications, alterations or attachments thereto which are not authorized by AMETEK;
- is installed or operated contrary to the instructions of AMETEK;
- is opened, modified or disassembled in any way without AMETEK's consent; or
- is used in combination with items, articles or materials not authorized by AMETEK.

The Buyer may not assert any claim that the Products are not in conformity with any warranty until the Buyer has made all payments to AMETEK provided for in the Purchase Order Agreement.

PRODUCT RETURN PROCEDURE

1. Request a Return Material Authorization (RMA) number from the repair facility (**must be done in the country in which it was purchased**):
 - **In the USA**, contact the AMETEK Repair Department prior to the return of the product to AMETEK for repair:
Telephone: 800-733-5427, ext. 2295 or ext. 2463 (toll free North America)
858-450-0085, ext. 2295 or ext. 2463 (direct)
 - **Outside the United States**, contact the nearest Authorized Service Center (ASC). A full listing can be found either through your local distributor or our website, www.programmablepower.com, by clicking Support and going to the Service Centers tab.
2. When requesting an RMA, have the following information ready:
 - Model number
 - Serial number
 - Description of the problem

NOTE: Unauthorized returns will not be accepted and will be returned at the shipper's expense.

NOTE: A returned product found upon inspection by AMETEK, to be in specification is subject to an evaluation fee and applicable freight charges.

This page intentionally left blank.

CONTENTS

SECTION 1 OVERVIEW	1-1
1.1 Introduction.....	1-1
1.2 IEEE 488.2 GPIB and RS232 Options.....	1-1
1.3 Ethernet Option.....	1-1
SECTION 2 IEEE 488.2 GPIB/RS232 FEATURES, FUNCTIONS AND SPECIFICATIONS.....	2-1
2.1 Introduction.....	2-1
2.2 Features.....	2-1
2.3 Programmable Functions.....	2-1
2.4 Readback Functions	2-2
2.5 Specifications.....	2-2
2.5.1 Programming Resolution	2-2
2.5.2 Programming Accuracy	2-2
2.5.3 Readback Resolution	2-2
2.5.4 Readback Accuracy.....	2-2
SECTION 3 IEEE 488.2 GPIB/ RS232 CONFIGURATIONS AND REMOTE PROGRAMMING	3-1
3.1 Rear Panel.....	3-1
3.2 RS232 Setup Procedure.....	3-3
3.3 GPIB/IEEE 488.2 Setup Procedure	3-4
3.3.1 Configuration Switch.....	3-5
3.3.2 Remote/Local Selection.....	3-6
3.3.3 Power-On GPIB Service Request (PON SRQ) Selection.....	3-8
3.3.4 Shield Ground.....	3-8
3.3.5 Address Selection.....	3-8
3.4 Remote Programming Via RS232	3-9

SECTION 4 ETHERNET INTERFACE FEATURES, FUNCTIONS AND SPECIFICATIONS 4-1

- 4.1 Introduction4-1
 - 4.1.1 Minimum System Requirements4-1
- 4.2 Features and Functions4-2
 - 4.2.1 Features4-2
 - 4.2.2 Programmable Functions4-3
 - 4.2.3 Readback Functions4-3
- 4.3 Specifications4-3
 - 4.3.1 Ethernet/LAN Configuration4-3
 - 4.3.2 Ethernet Configuration Factory Defaults4-4
 - 4.3.3 Programming Resolution4-4
 - 4.3.4 Programming Accuracy4-4
 - 4.3.5 Readback Resolution4-5
 - 4.3.6 Readback Accuracy4-5

SECTION 5 ETHERNET CONFIGURATION AND REMOTE PROGRAMMING 5-1

- 5.1 Rear Panel5-1
- 5.2 Ethernet Setup Procedure.....5-3
 - 5.2.1 Network Setup Using DHCP5-4
 - 5.2.2 Network Setup Using Auto-IP5-5
 - 5.2.3 Network Setup Using the Serial COM Port5-6
 - 5.2.4 Network Setup Using Web Browser.....5-7
 - 5.2.5 Configuration Switch5-8
 - 5.2.6 Remote/Local Selection5-9
- 5.3 External User Control Signal Connector5-10
- 5.4 Programming/Communication Via Ethernet.....5-13
 - 5.4.1 Raw Socket Interface5-13
 - 5.4.2 VXI-11 Protocol5-13
 - 5.4.3 Web Server5-13
- 5.5 Ethernet Web Pages, Overview5-14
 - 5.5.1 HOME5-16
 - 5.5.2 IP CONFIGURATION.....5-17
 - 5.5.3 SETTINGS5-21
 - 5.5.4 STATUS5-24
 - 5.5.5 POWER5-26
 - 5.5.6 PRESETS5-28
 - 5.5.7 SECURITY5-30

SECTION 6 IEEE 488.2 GPIB/RS232/ETHERNET AND SCPI	
COMMAND OPERATION	6-1
6.1 Introduction	6-1
6.2 Register Definitions	6-1
6.2.1 SCPI Status Byte	6-1
6.2.2 Standard Event Status Register (ESR)	6-3
6.2.3 Protection Condition and Protection Event Status Register	6-3
6.2.4 Operation Status and Questionable Status Registers	6-5
6.2.5 Error/Event Queue	6-5
6.2.6 Serial Poll Operation	6-8
6.3 Ethernet LXI™, VXI-11, and SCPI Conformance Information	6-8
6.3.1 Parameter Definitions	6-8
6.3.2 Units	6-9
6.3.3 Conventions	6-9
6.3.4 Queries	6-9
6.4 IEEE 488.2 Common Command Subsystem	6-10
6.5 SOURCE SCPI Command Subsystem	6-12
6.5.1 SOURCE SCPI Command Summary	6-12
6.5.2 SOURCE SCPI Command Reference	6-13
6.5.3 RAMP FUNCTION	6-16
6.6 MEASURE SCPI Command Subsystem	6-17
6.6.1 MEASURE SCPI Command Summary	6-17
6.6.2 MEASURE SCPI Command Reference	6-17
6.7 OUTPUT SCPI Command Subsystem	6-18
6.7.1 OUTPUT SCPI Command Summary	6-18
6.7.2 OUTPUT SCPI Command Reference	6-18
6.8 STATUS SCPI Command Subsystem	6-19
6.8.1 STATUS SCPI Command Summary	6-19
6.8.2 STATUS SCPI Command Reference	6-20
6.9 SYSTEM SCPI Command Subsystem	6-21
6.9.1 SYSTEM SCPI Command Summary	6-21
6.9.2 SYSTEM SCPI Command Reference	6-22
6.10 HTRIGGER SCPI Command Subsystem	6-25
6.10.1 HTRIGGER SCPI Command Summary	6-25
6.10.2 HTRIGGER SCPI Command Reference	6-25
6.11 TRIGGER SCPI Command Subsystem	6-26
6.11.1 TRIGGER SCPI Command Summary	6-26
6.11.2 TRIGGER SCPI Command Reference	6-26
6.12 CALIBRATION SCPI Command Subsystem	6-27
6.12.1 CALIBRATION SCPI Command Summary	6-27

6.12.2	CALIBRATION SCPI Command Reference	6-29
6.13	SGI-Unique Commands	6-32
6.13.1	Restrictions on Sequence Programming:.....	6-32
6.13.2	SGI SOURCE SCPI Command Subsystem	6-33
6.13.3	SGI PROGRAM SCPI Command Subsystem	6-34
6.13.4	SGI MEASURE SCPI Command Subsystem.....	6-41
6.13.5	SGI HTRIGGER SCPI Command Subsystem	6-41
6.14	Examples of Using the SCPI Commands	6-42
6.14.1	VI Mode Example	6-42
6.14.2	OVP Setup Example	6-42
6.14.3	Trigger Example	6-43
6.14.4	Hardware Trigger Example	6-44
6.14.5	Ramp V Example	6-44
6.14.6	Ramp I Example.....	6-44
6.14.7	Ramp V Example 2	6-45
6.14.8	Power On INIT Example	6-45
6.14.9	Sequence Creation and Execution Examples.....	6-46
 SECTION 7 CALIBRATION		 7-1
7.1	Introduction	7-1
7.2	Setup for Calibration	7-2
7.3	Voltage Programming Calibration (Ethernet)	7-3
7.4	Voltage Program Gain/Offset and Measurement Readback Calibration (Ethernet, GPIB) 7-5	
7.5	Overvoltage Protection Programming Calibration (Ethernet, GPIB)	7-6
7.6	Current Programming Calibration (Ethernet)	7-7
7.7	Current Programing gain/offset and Measurement Readback Calibration (Ethernet, GPIB).....	7-9
7.8	ANALOG PROGRAM ADJUSTMENT.....	7-11
7.8.1	Adjustment for Current Mode.....	7-13
7.8.2	Adjustment for Voltage Mode.....	7-14
 SECTION 8 SCPI STATUS IMPLEMENTATION		 8-1
 List of Tables		
Table 3-1.	Remote/Local Switch	3-6
Table 3-2.	Remote Power-on Conditions.....	3-7
Table 5-1.	Remote/Local Switch	5-9
Table 5-2.	Remote Mode Power-on Conditions.....	5-10
Table 5-3.	External User Control Signal Connector Pinout – Ethernet only	5-11

Table 6-1. SCPI Status Byte.....	6-2
Table 6-2. Standard Event Status Register.....	6-3
Table 6-3. Protection Condition and Event Status Registers.....	6-4
Table 6-4. SCPI Error Codes.....	6-5
Table 6-5. System Fault Registers.....	6-24

List of Figures

Figure 3-1. SG Unit with GPIB/RS232 option.....	3-1
Figure 3-3. SG Unit with RS232 only.....	3-2
Figure 3-5. SGA Configuration Switch for GPIB.....	3-5
Figure 3-6. SGI 8-pin Configuration Switch for GPIB or Ethernet.....	3-5
Figure 3-7. SGI 4-pin Configuration Switch for Ethernet.....	3-5
Figure 5-1. SG Rear Panel with Ethernet/RS232 Options.....	5-1
Figure 5-2. SG Rear Panel with Ethernet/RS232 Options.....	5-2
Figure 5-3. SGI Rear Panel with Ethernet/RS232 Options (4-pin Config Switch shown).....	5-3
Figure 5-4. Power Supply's Home Page (SGI shown here).....	5-5
Figure 5-5. SG 8-pin Configuration Switch for the Ethernet Option.....	5-8
Figure 5-6. SG 4-pin Configuration Switch for the Ethernet Option.....	5-8
Figure 5-7. External User Connector (rear panel view) Designation (10-pin Molex).....	5-11
Figure 5-9. SGI Banner and Tabs.....	5-14
Figure 5-15. Alert Message for Save Settings.....	5-23
Figure 5-16. Status Page.....	5-24
Figure 5-20. Add New User Window from Security Page.....	5-31
Figure 5-21. Edit Existing User Window from Security Page.....	5-32
Figure 6-1. Power Supply Output for Example 1.....	6-47
Figure 6-3. Power Supply Output for Example 2.....	6-48
Figure 6-5. Power Supply Output for Example 3.....	6-50
Figure 6-7. End-of-Sequence Pause for Example 4.....	6-51
Figure 6-9. Power Supply Output for Example 5.....	6-55
Figure 6-11. Power Supply Output for Example 6.....	6-56
Figure 6-13. Power Supply Output for Example 7.....	6-59
Figure 7-1. Potentiometer Locations.....	7-12
Figure 7-2. Precision Current Shunt.....	7-13
Figure 7-3. Remote Current Programming Using 0-5 VDC or 0-10 VDC Voltage Source.....	7-13
Figure 7-4. SGI Front Panel.....	7-14
Figure 7-5. Remote Voltage Programming Using 0-5 VDC or 0-10 VDC Voltage Source.....	7-15
Figure 7-6. Analog Control Connector (J1).....	7-15

This page intentionally left blank.

SECTION 1 OVERVIEW

1.1 INTRODUCTION

This manual provides instructions for full remote programming control and monitoring from a computer, for your SG series high power DC power supply. For easy navigation to the applicable instructions, this manual separates GPIB and RS232 setup instructions from Ethernet setup instructions. The instructions then converge where they are common to all three interface options. See Sections 1.2 and 1.3 for orientation. Use this programming manual in conjunction with your SGA or SGI Operation manual.

1.2 IEEE 488.2 GPIB AND RS232 OPTIONS

If you are using the IEEE 488.2 GPIB or RS232 interface, go to:

- Section 2 for features, functions and specifications,
- Section 3 for configuration and remote programming setup
- Section 6 for SCPI commands and definitions
- Section 7 for calibration procedures
- Section 8 for SCPI Status Implementation

1.3 ETHERNET OPTION

If you are using an Ethernet interface, go to:

- Section 4 for features, functions, and specifications
- Section 5 for configuration and for programming setup of your SG power supply via the Ethernet
- Section 6 for SCPI commands and definitions
- Section 7 for calibration procedures
- Section 8 for SCPI Status Implementation

This page intentionally left blank.

SECTION 2

IEEE 488.2 GPIB/RS232 FEATURES, FUNCTIONS AND SPECIFICATIONS

2.1 INTRODUCTION

This section introduces the features, functions and specifications for IEEE 488.2 GPIB and RS232.

2.2 FEATURES

- 16-bit programming and 16-bit readback of voltage and current
- Programmable overvoltage protection with reset
- IEEE 488.2 and SCPI compliant command set
- User selectable Constant-Voltage/Constant-Current or Foldback mode, with reset
- Voltage Ramp and Current Ramp functions
- Field-upgradable firmware via RS232
- Soft calibration
- Rear panel IEEE 488.2 and RS232 control interface
- Rear panel configuration switch

2.3 PROGRAMMABLE FUNCTIONS

- Output voltage and current
- Soft limits for voltage and current
- Overvoltage protection
- Output enable/disable
- Maskable fault interrupt
- Hold and trigger
- Full calibration

2.4 READBACK FUNCTIONS

- Actual measured voltage and current
- Voltage and current settings
- Soft voltage and current limits
- Overvoltage protection setting
- Status and Accumulated Status registers
- Programming error codes
- Fault codes
- Manufacturer, power supply model, and firmware version identification

2.5 SPECIFICATIONS

Specifications are subject to change without notice. Refer to your SGA or SGI power supply operation manual for effects of line regulation, load regulation, and temperature on accuracy specifications.

2.5.1 Programming Resolution

Voltage: 0.002% of full scale

Current: 0.002% of full scale

Overvoltage Protection: 0.002% of full scale (full scale is 110% of max output voltage.)

2.5.2 Programming Accuracy

Voltage: \pm (0.1% of maximum output voltage)

Current: \pm (0.4% of maximum output current)*

Overvoltage Protection: \pm (1.0% of max output voltage)

* After 30 minutes operation with fixed line, load, and temperature.

2.5.3 Readback Resolution

Voltage: \pm 0.002% of full scale

Current: \pm 0.002% of full scale

2.5.4 Readback Accuracy

Voltage: \pm (0.15% of full scale output voltage)

Current: \pm (0.4% of full scale output current)*

* After 30 minutes operation with fixed line, load, and temperature.

SECTION 3

IEEE 488.2 GPIB/ RS232 CONFIGURATIONS AND REMOTE PROGRAMMING

3.1 REAR PANEL

This section provides illustrations of the SG power supply's rear panel layout, which differs among the SG models. Figure 3-1, Figure 3-2 and Figure 3-3 are examples. Regardless of the layout, the component functions are common across all models, and those that are pertinent to the RS232 and IEEE 488.2 GPIB options are described here.

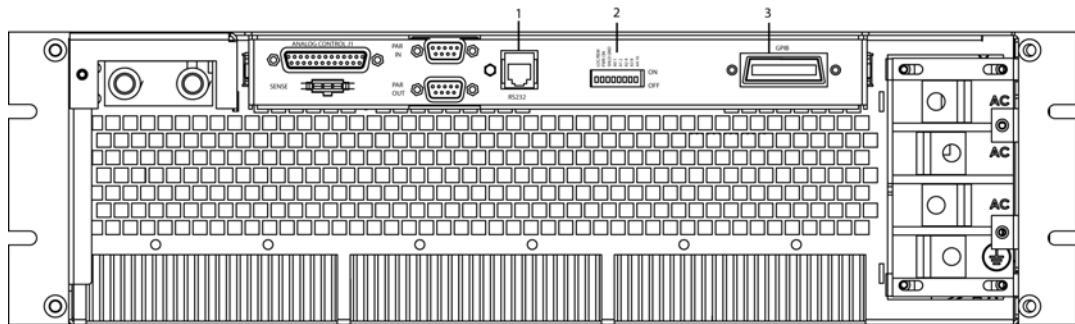

Figure 3-1. SG Unit with GPIB/RS232 Option

- 1 – RS232 (RJ-11) connector
- 2 – Configuration Switch (may be 8-pin or 4-pin) - for correct settings see Section 3.3.1.
- 3 – IEEE 488.2 GPIB connector

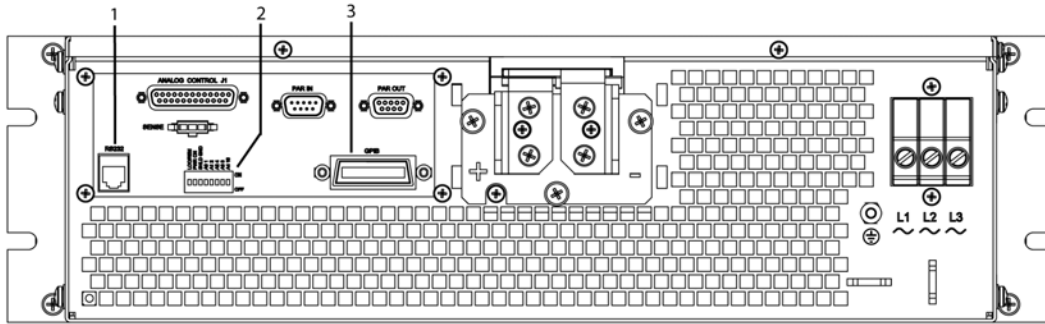

Figure 3-2. SG Unit with GPIB/RS232 Option

- 1 – RS232 (RJ-11) connector
- 2 – Configuration Switch (may be 8-pin or 4-pin) - for correct settings see Section 3.3.1
- 3 – IEEE 488.2 GPIB connector

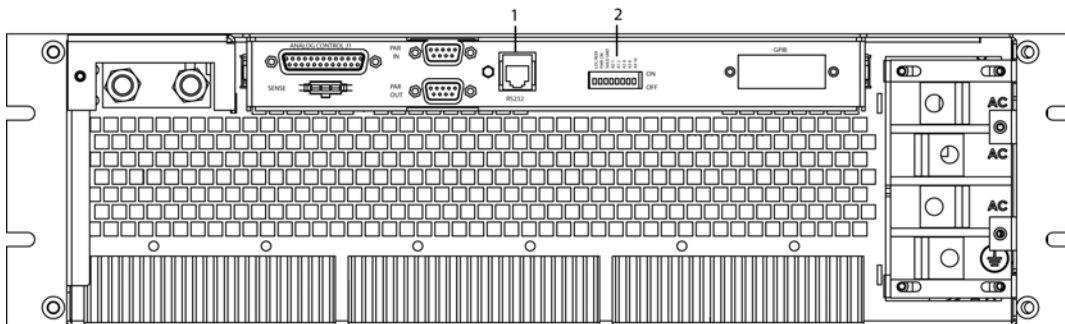

Figure 3-3. SG Unit with RS232 only

- 1 – RS232 (RJ-11) connector
- 2 – Configuration Switch (may be 8-pin or 4-pin). For correct settings see Section 3.3.1

3.2 RS232 SETUP PROCEDURE

This procedure is a quick reference for the configuration requirements for RS232. Refer to Section 3.3.1 for detailed information on the rear panel configuration switches.

1. Build an RS232 comm cable per the following pinout description, which is illustrated in Figure 3-4:

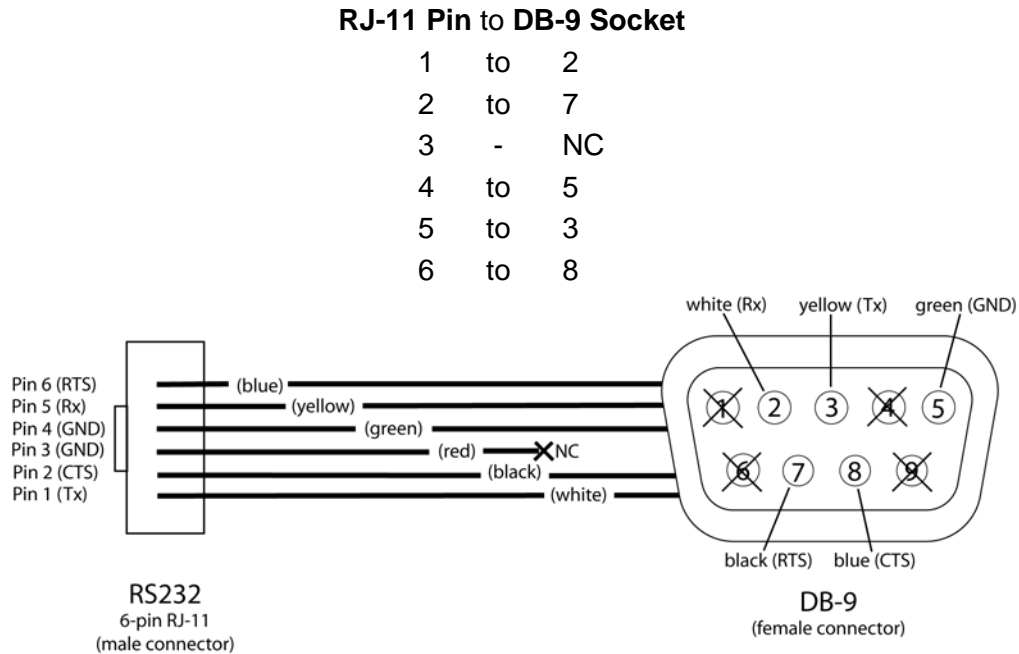

Figure 3-4. RS232 Comm Cable Wiring

2. Set the rear panel Remote/Local switch to Remote (On or 1).
3. Connect power to the unit and turn on the unit.
4. **SGA:** skip this step and go to the next step.
SGI: From the Home menu page 3, press (F1) to enter the Remote menu. Using the up-down arrows of the NAVPAD (see SGI Operation Manual) change the baud rate for RS232 to 19200.
5. Use one of the available programs for serial communication, such as MS HyperTerminal™, and set the RS232 baud rate to 19200, 8 data bits, no parity, 1 stop bit, and no flow control.

If you choose to use MS HyperTerminal™:

- a. After inputting the above parameters, in the HyperTerminal™ window click the disconnect icon and then the properties icon.
- b. In the properties window select the Settings tab.
- c. In the Settings window click the ASCII Setup button.
- d. In the ASCII Setup window in the ASCII Sending section, check “Echo typed characters locally” and in the ASCII Receiving section, check “Append line feeds to incoming line ends.” Leave all other check boxes in their default state.

6. Establish communication.
7. Test the communication interface by issuing the *IDN? Command. This returns the supply's model and serial numbers, and software version(s), as well as the last calibration date, and does not affect the output of the supply. (If using SGI, navigate to the INFO page of the SGI unit's front panel display to verify).

3.3 IEEE 488.2 GPIB SETUP PROCEDURE

1. Set the rear panel Local/Remote switch to Remote (On or 1).
2. **SGA:** select the GPIB address using the rear panel DIP switches.
SGI: set the GPIB address via the front panel menu (Refer to SGI Operation manual).
3. Connect GPIB cable from the controlling computer to the power supply.
NOTE: If operating in an inherently noisy environment, e.g., high RF or other radiated emissions, a double-shielded GPIB cable is recommended.
4. Connect power to the unit and turn on the unit.
5. Using a GPIB communication software, test the communication interface by issuing the *IDN? Command. This returns the supply's model and serial numbers, and software version(s), as well as the last calibration date, and does not affect the output of the supply. (If using SGI, navigate to the INFO page of the SGI unit's front panel display to verify).

3.3.1 Configuration Switch

The DIP switch (may be 8-pin or 4-pin) is accessible from the rear panel to configure the supply for your particular system and application. The following figures show the configuration, as set up in Section 3.2, and with GPIB address set to five (5) for the SGA. In the SGI only Remote/Local position is used, addressing is done through the front panel menu (See SGI operation manual).

Note: There is one of two types of DIP switches: toggle or rocker. For **toggle** switches, the shading indicates the position of the toggle switch. For **rocker** switches, the shading indicates the depressed side.

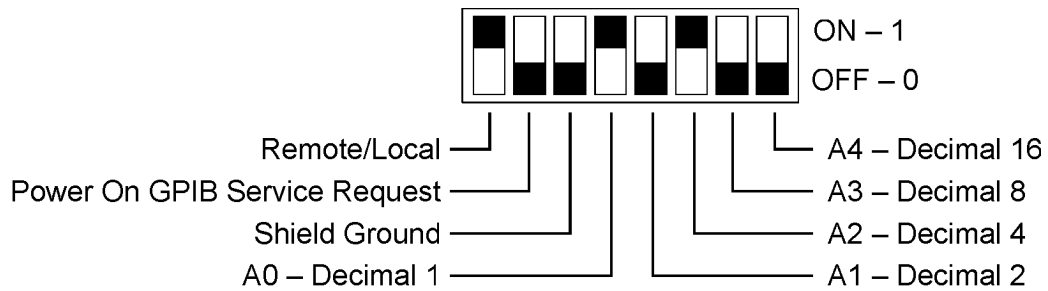

Figure 3-5. SGA Configuration Switch for GPIB

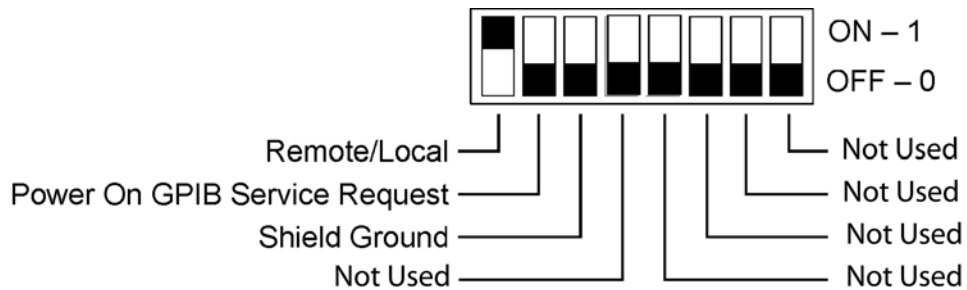

Figure 3-6. SGI 8-pin Configuration Switch for GPIB or Ethernet



Figure 3-7. SGI 4-pin Configuration Switch for Ethernet

3.3.2 Remote/Local Selection

Set the rear panel Remote/Local switch to select remote or local operation.

Remote ON switch (rocker) is top depressed.

Table 3-1. Remote/Local Switch

Switch Position	Description
ON	Remote operation selected. *
OFF	Local operation selected, and front panel control is enabled. NOTE: Unit will switch to remote operation upon issuing the first GPIB or RS232 non-query command.

* In the ON position, the power hardware and GPIB card initialize to the remote state at power-on.

When in remote operation, the front panel control remains disabled regardless of the state of the GPIB interface REN (Remote ENable) line or the GTL (Go To Local) command.

To revert to front panel control, use the special command **SYST:LOCAL** <on/off>.

Powering up in remote mode will result in the operating conditions described in Table 3-2.

Table 3-2. Remote Power-on Conditions

Condition	Default
Voltage	0 Volts (initial from factory power-on voltage); otherwise, last value saved by SCPI command. See CAL:INIT:VOLT
Current	0 Amps (initial from factory power-on current); otherwise, last value saved by SCPI command. See CAL:INIT:CURR
Soft Voltage Limit	Model maximum voltage *
Soft Current Limit	Model maximum current *
OVP Trip Voltage	Model maximum voltage +10% (initial from factory power-on OVP); otherwise, last value saved by SCPI command. See CAL:INIT:VOLT:PROT
Delay	0.5 seconds
Foldback Protection	OFF (non-configurable)
Output	ON ** See CAL:MOD:POWERON
Hold	OFF
Unmask	NONE
Service Request Capability	OFF

* User-programmable temporary limit (reverts to power-on defaults after power cycle or Reset command is issued).

** User-selectable.

3.3.3 Power-On GPIB Service Request (PON SRQ) Selection

Set the rear panel PON SRQ switch to ON to cause a GPIB service request to be sent to the computer controller when the supply is turned on.

POWER-ON GPIB SERVICE REQUEST (PON SRQ) SWITCH

Switch Position	Description
ON	Power-On SRQ selected
OFF	No Power-On SRQ selected

Refer to your specific GPIB controller card manual for further details on serial polling.

3.3.4 Shield Ground

Connects GPIB cable shield to chassis ground.

3.3.5 Address Selection

The address selection for a unit is the GPIB address of that device (1-30). SCPI reserves channel 0 as the global channel to address all channels.

The **SGA** address selection is binary with switch A0 as the LSB, and with switch A4 as the MSB. The rear panel switch illustration in Section 3.3.1 shows the address selection 00101 in binary (5 decimal).

The **SGL** address is selected and enabled from a list in the Remote menu. See SGL Operation manual for more details on Remote menu, Navigation and Editing.

ADDRESS SWITCHES

Switch Position	Description
ON	1
OFF	0

3.4 REMOTE PROGRAMMING VIA RS232

The RS232 interface operates at fixed 19.2K baud for **SGA** and is selectable from 2400 to 19.2K baud for the **SGI**, with 8 data bits, no parity, and 1 stop bit.

All commands are supported at the RS232 interface with the exception of the Service Request (SRQ) function, which is a GPIB-specific function requiring the dedicated Service Request line of the IEEE 488.2 interface. In this case, the SRQ function has no effect. The RS232 interface is accessible through the rear panel 6-pin RJ-11 connector (Figure 3-8), labeled RS232 on the power supply's rear panel (see Figure 3-1, Figure 3-2 and Figure 3-3).

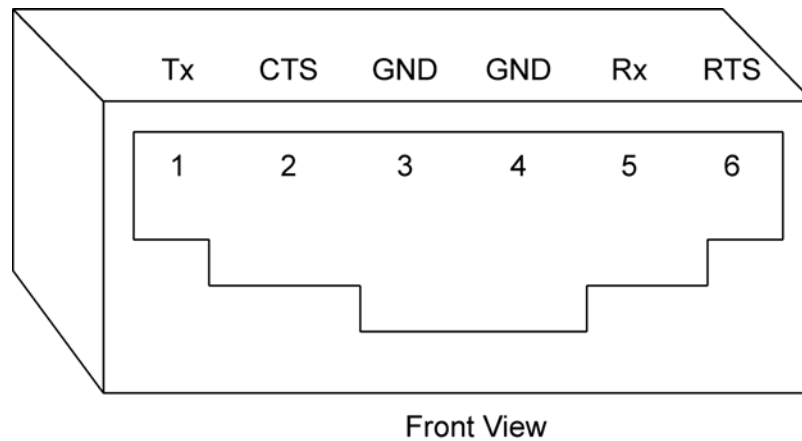

Figure 3-8. RS232 Rear Panel RJ-11 Connector Pinout

This page intentionally left blank.

SECTION 4

ETHERNET INTERFACE FEATURES, FUNCTIONS AND SPECIFICATIONS

4.1 INTRODUCTION

This section covers the Remote Programming Ethernet Interface Option for the SG series power supplies. This optional configuration enables you to operate your Sorensen power supply from a computer via Ethernet IEEE-802.3 or RS232 communication protocols, or with SCPI-compatible language, allowing full remote programming control and monitoring of your power supply.

An important point is that this Ethernet option is **LXI™** (LAN eXtensions for Instrumentation) class C compliant. LXI™ is an instrumentation platform based on industry-standard Ethernet technology designed to provide ease of integration by modularity, flexibility and performance.

4.1.1 Minimum System Requirements

The minimum software and equipment requirements to operate your Sorensen Ethernet product depend on whether it is connected directly to your PC or connected to the Internet or to a Local Area Network (LAN).

PC CONNECTION

To operate your Sorensen product with Ethernet option connected directly to a PC (no Internet or LAN connection), you will need:

- Pentium-based laptop or desktop computer running Microsoft Windows XP (or better)
- Ethernet based Network Interface Card (NIC) or built-in port capable of 10/100 MBit operation
- CAT 5 cable Ethernet crossover cable
- Microsoft Internet Explorer version 6.0 or later
- Sun Microsystems Java Runtime Environment

INTERNET OR LAN CONNECTION

To operate your Sorensen Ethernet product connected to the Internet or a LAN you will need:

- Pentium-based laptop or desktop computer running Microsoft Windows XP (or better)
- Ethernet based Network Interface Card (NIC) or built-in port capable of 10/100 MBit operation
- Appropriate Ethernet modem for Internet connection, or
- Switch or hub (Linksys brand strongly recommended) for LAN connection
- Standard CAT 5 Ethernet interconnect cable
- Microsoft Internet Explorer version 6.0 or later
- Sun Microsystems Java Runtime Environment

4.2 FEATURES AND FUNCTIONS

4.2.1 Features

- Ethernet/LAN connectivity, 10/100base-T compatible
- Fully **LXI**[™] (LAN eXtensions for Instrumentation) class C compliant
- Built-in Web Server for direct control using Internet Explorer 6.0 or higher
- 16-bit programming and 16-bit readback of voltage and current
- Programmable overvoltage protection with reset
- SCPI compliant command set
- User-programmable signals including Local/Remote Sense relay drive, External Polarity relay drive, and Disconnect (Isolate) Relay Drive
- User selectable Constant-Voltage/Constant-Current or Foldback mode, with reset
- Voltage Ramp and Current Ramp functions
- Field-upgradeable firmware via RS232
- Full calibration through software control
- Rear panel Ethernet/IEEE-802.3 and RS232 control interface
- Rear panel External User Control Signal Interface (Includes optically isolated external hardware trigger input)
- Rear panel configuration switch

4.2.2 Programmable Functions

- Output voltage and current
- Soft limits for voltage and current
- Overvoltage protection
- Output enable/disable
- Maskable fault interrupt
- Hold and trigger
- External relay control
- Full calibration

4.2.3 Readback Functions

- Measured voltage and current
- Voltage and current settings
- Soft voltage and current limits
- Overvoltage protection setting
- Status and Accumulated Status registers
- Programming error codes
- Fault codes
- Manufacturer, power supply model, and firmware version identification

4.3 SPECIFICATIONS (SUBJECT TO CHANGE WITHOUT NOTICE)

4.3.1 Ethernet/LAN Configuration

- Ethernet: IEEE-802.3 compliant
- Medium: 10/100 base-T
- Connection Monitoring: Media Sense supported
- Protocol: TCP/IP, IPV4
- ICMP (ping server): Enable (default)/Disable
- IP Address Assignment: Automatic via DHCP (Primary default), Static, or Automatic Private IP Addressing (Auto-IP, Secondary default)
- VXI-11 Discovery: Supported
- Security: Password protected access, and selective permissions for each user

4.3.2 Ethernet Configuration Factory Defaults

PARAMETER	DEFAULT
Host Name	SGx<base model>-<last four digits of serial number>
Description	Sorensen Power Supply SGx<base model>
IP Address	DHCP-acquired (Primary default*) If DHCP absent, assigned via Auto-IP (Secondary default*)
IP Addressing mode	DHCP-acquired (Primary default*)
Subnet Mask	DHCP-acquired (Primary default*) If DHCP absent, assigned via Auto-IP (Secondary default*)
Gateway	0.0.0.0
DNS Server	0.0.0.0
Listening Port	9221
User ID	admin
Password	password
Ping Echo	On

*** Primary/Secondary defaults:**

The Ethernet interface provides the opportunity to set both a Primary and a Secondary IP configuration in the IP Configuration page (Section 5.5.2). If the Primary fails, the system defaults to the Secondary configuration. However, both setting “DHCP-acquired” *and* selecting “Auto IP Enabled” together in the Primary configuration, prevents the power supply from trying the Secondary configuration. Please see “TCP/IP Configuration” and “Auto IP Enabled” under IP Configuration, Section 5.5.2 for more detail.

4.3.3 Programming Resolution

	SGA	SGI
Voltage	0.002% of full scale	0.002% of full scale
Current	0.002% of full scale	0.002% of full scale
Overvoltage Protection	0.002% of full scale (full scale is 110% of max output voltage.)	0.002% of full scale (full scale is 110% of max output voltage.)

4.3.4 Programming Accuracy

	SGA	SGI
Voltage	± (0.1% of maximum output voltage)	± (0.1% + 0.1% of full scale)
Current	± (0.25% of full scale output current)	± (0.1% + 0.4% of full scale)
Overvoltage Protection	± (0.5% of max output voltage)	± (0.5% + 0.5% of full scale) (full scale 110% of max. output voltage)

4.3.5 Readback Resolution

	SGA	SIG
Voltage	0.002% of full scale	0.02% of full scale
Current	0.002% of full scale	0.02% of full scale

4.3.6 Readback Accuracy

	SGA	SIG
Voltage	\pm (0.1% of full scale output voltage)	\pm (0.1% + 0.15% of maximum output voltage)
Current*	\pm (0.25% of full scale output current)*	\pm (0.1% + 0.4% of maximum output current)

* After 30 minutes operation with fixed line, load, and temperature.

Note: Refer to the applicable power supply manual (SGA or SIG) for effects of line regulation, load regulation, and temperature on accuracy specifications.

This page intentionally left blank.

SECTION 5

ETHERNET CONFIGURATION AND REMOTE PROGRAMMING

5.1 REAR PANEL

This section provides illustrations of the SG power supply's rear panel layout, which differs among the SG models. Figure 5-1, Figure 5-2 and Figure 5-3 are examples. Regardless of the layout, the component functions are common across all models, and those that are pertinent to the Ethernet option are described here.

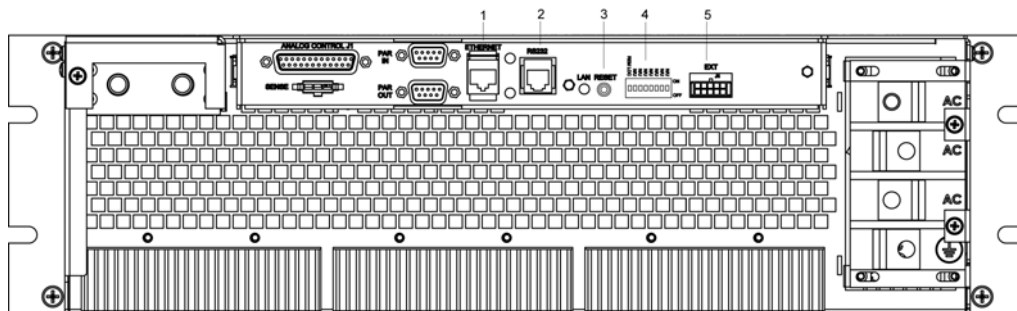

Figure 5-1. SG Rear Panel with Ethernet/RS232 Options

- 1** – Ethernet (RJ-45) connector. Adjacent to the RJ-45 connector are two green LEDs. If one of the LEDs is lit, the link is connected either to a hub switch or to another host. If both are lit, the connection speed is 100MB.
- 2** – RS232 (RJ-11) connector.
- 3** – Reset switch and green dual-purpose NET LED.
Reset switch (must be depressed until NET LED begins blinking, which could take five or more seconds) returns configuration parameters to factory default settings (see Section 4.3.2).
NET LED: when solid-lit, indicates Network Connectivity; blinking indicates Instrument ID (See “Instrument ID” in **Settings**, Section 5.5.3). If the LED is off, there is no Ethernet connection found by the power supply.
- 4** – Configuration Switch (may be 8-pin or 4-pin). For correct settings see Section 5.2.5)
- 5** – External User Control Signal Connector (see Section 5.3)

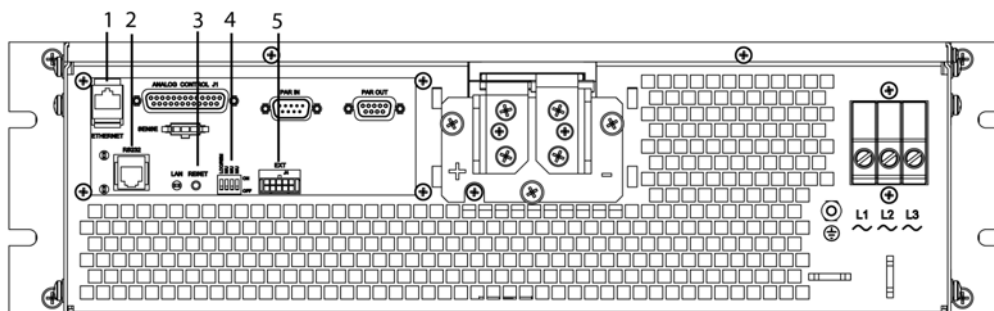

Figure 5-2. SG Rear Panel with Ethernet/RS232 Options

- 1 – Ethernet (RJ-45) connector. Adjacent to the RJ-45 connector are two green LEDs. If one of the LEDs is lit, the link is connected either to a hub switch or to another host. If both are lit, the connection speed is 100MB.
- 2 – RS232 (RJ-11) connector.
- 3 – Reset switch and green dual-purpose NET LED.
Reset switch (must be depressed until NET LED begins blinking, which could take five or more seconds) returns configuration parameters to factory default settings (see Section 4.3.2).
NET LED: when solid-lit, indicates Network Connectivity; blinking indicates Instrument ID (See “Instrument ID” in **Settings**, Section 5.5.3). If the LED is off, there is no Ethernet connection found by the power supply.
- 4 – Configuration Switch (may be 8-pin or 4-pin). For correct settings see Section 5.2.5)
- 5 –External User Control Signal Connector (see Section 5.3)

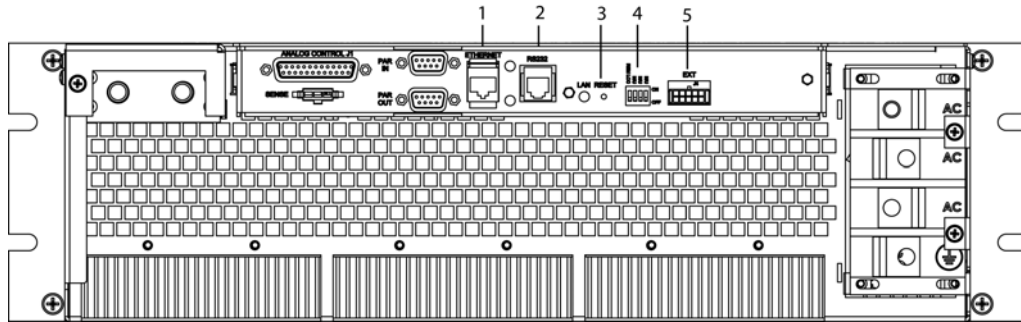

Figure 5-3. SGI Rear Panel with Ethernet/RS232 Options (4-pin Config Switch shown)

- 1 – Ethernet (RJ-45) connector. Adjacent to the RJ-45 connector are two green LEDs. If one of the LEDs is lit, the link is connected either to a hub switch or to another host. If both are lit, the connection speed is 100MB.
- 2 – RS232 (RJ-11) connector.
- 3 – Reset switch and green dual-purpose NET LED.
Reset switch (must be depressed until NET LED begins blinking, which could take five or more seconds) returns configuration parameters to factory default settings (see Section 4.3.2).
NET LED: when solid-lit, indicates Network Connectivity; blinking indicates Instrument ID (See “Instrument ID” in **Settings**, Section 5.5.3). If the LED is off, there is no Ethernet connection found by the power supply.
- 4 – Configuration Switch (may be 8-pin or 4-pin). For correct settings see Section 5.2.5)
- 5 – External User Control Signal Connector (see Section 5.3)

5.2 ETHERNET SETUP PROCEDURE

The Ethernet option is installed into the supply at the factory. Use the Setup Procedure that applies to your system and application to configure the Ethernet.

There are four methods of setting the IP address of the unit, each of which is described in the subsections that follow:

- Set an IP address through DHCP (Primary default).
- If DHCP is not available, the unit can assign itself an IP address in the Auto-IP (dynamic link local addressing) range (Secondary default).
- Use the serial communications port to manually assign an IP address. (IP address can be set via the front panel on SGI units.)
- Set the IP address through the Web page interface.

NOTE: The SG Ethernet Option has been designed and tested to be fully compatible with Microsoft Internet Explorer 6.0. This is the only browser supported by Elgar Electronics Corporation (EEC) in its Ethernet-based products. Earlier versions of Explorer (or browsers by other companies) may or may not work correctly, and as such, are not supported by EEC.

5.2.1 Network Setup Using DHCP

Before beginning this procedure, get access to the DHCP server or see your network administrator to get the IP address assigned to the power supply.

NOTE: The power supply is VXI-11 compliant, so even without access to the DHCP server, it is still possible to discover the IP address assigned to the power supply with programs such as National Instrument's NI-VISA.

1. Start with the power supply in the power-off state.
2. Connect a RJ-45 network cable from the power supply to the network with the DHCP server.
3. Power on the power supply and allow the power supply to perform its initialization.
4. Identify the IP address assigned to the power supply by accessing the DHCP server, by any of three ways:
 - asking your network administrator
 - discovering it with a VXI-11 compliant discover program
 - connect using a computer serial communications program such as HyperTerminal™ set for 19200 baud, no parity, 8 data bits, 1 stop bit and request the IP address with the command, **SYST:NET:IP?**<Enter>. You will receive a response that includes two IP addresses in the form of four sets of octets separated by a dot: e.g., 192.168.4.3 and 92.168.4.3 or 0.0.0.0 and 72.32.3.5

If you choose to use MS HyperTerminal™ to identify the IP address:

- a. After inputting the above parameters (baud rate, etc.), in the HyperTerminal™ window click the disconnect icon and then the properties icon.
 - b. In the properties window select the Settings tab.
 - c. In the Settings window click the ASCII Setup button.
 - d. In the ASCII Setup window in the ASCII Sending section, check "Echo typed characters locally" and in the ASCII Receiving section, check "Append line feeds to incoming line ends." Leave all other check boxes in their default state.
5. The SG Ethernet hardware is now configured. Open Internet Explorer 6 or higher, or compatible Web browser and enter the IP address of the power supply to view the Home page of the power supply. Figure 5-4 shows the SGI Power Supply Home page; the SGA Power Supply

Interface differs in that its banner shows “SGA” and it does not come with the POWER or PRESETS pages.

Model: SGI160/94C-2GAA
Manufacturer: Elgar Electronics Corporation
Serial Number: DVTSGE0408
Firmware Revision: 1.06
Boot Monitor Revision: 1.00
VISA Resource: TCPIP0::172.16.21.174::9221::SOCKET
LXI Compliance: Class C, Version 1.0
Host Name: S-SGI160/94C-2G
Description: Sorensen Power Supply SGI160/94C-2GA
MAC Address: 00-06-D0-00-03-4E
TCP/IP Address: 172.16.21.174
Subnet Mask: 255.255.0.0
Gateway: 172.16.1.57
DNS Server: 172.16.1.61
Listening Port: 9221

Figure 5-4. Power Supply's Home Page (SGI shown here)

5.2.2 Network Setup Using Auto-IP

For this method, use a VXI-11 compliant discovery program such as National Instrument's NI-VISA to discover the IP address assigned to the power supply. The power supply will assign itself an IP address in the IP address range from 169.254.0.1 to 169.254.255.254 with a subnet mask of 255.255.0.0.

NOTE: When connecting your Sorensen unit to a network, Elgar strongly recommends using Linksys® hubs or switches, which have undergone extensive compatibility testing with the Ethernet interface.

1. Start with the power supply in the power-off state.
2. Connect a crossover cable from the power supply directly to your PC.
3. If the PC is already configured to obtain an IP address automatically, skip to Step 4. Otherwise:
 - a. In Windows click **Start, Settings, Control Panel.**

- b. Click open **Network Connections**. (For XP, if in the Category View, click Network and Internet Connections, and then Network Connections).
 - c. In the Network Connections window, right click the icon for the network adapter used to connect to the power supply, and click **Properties**.
 - d. Find the TCP/IP protocol item under the **Configuration** tab (for XP: find the item under the **General** tab), and click **Properties**. Select **Obtain an IP Address Automatically**.
 - e. Click **OK** to save the change.
 - f. Click **OK** again to apply the settings to the network adapter.
4. In Windows, click **Start**, and then **Run...**
 5. In the Run window, type "ipconfig /release" and click **OK**.
 6. Again click **Start**, and then **Run...**
 7. In the Run window, type "ipconfig /renew" and click **OK**. Your PC will assign itself an IP address in the Auto-IP range.
 8. Power on the power supply and allow the power supply to perform its initialization.
 9. Identify the IP address assigned to the power supply by discovering it with a VXI-11 compliant discover program.
 10. Continue by following the procedure in Section 5.2.4.

NOTE: When Auto-IP assigns an IP address, Web page connections will time out after 5 minutes of inactivity, which requires logging in again.

5.2.3 Network Setup Using the Serial COM Port

1. Connect from the PC COM1 port to the power supply's RS232 port (see Figure 5-1 for port location) using a straight-through DB91 to RJ-1 connector.
2. Have ready the IP address (e.g. 192.168.0.200) and subnet mask (e.g., 255.255.255.0) to be assigned to the power supply.
3. Run a serial terminal program, such as MS HyperTerminal™. Set the baud rate (bits per second) to 19200, data bits to 8, parity to none, stop bits to 1, flow control to none. Establish the connection.

If you choose to use MS HyperTerminal™:

- a. After inputting the above parameters, in the HyperTerminal™ window click the disconnect icon and then the properties icon.
- b. In the properties window select the Settings tab.
- c. In the Settings window click the ASCII Setup button.

- d. In the ASCII Setup window in the ASCII Sending section, check “Echo typed characters locally” and in the ASCII Receiving section, check “Append line feeds to incoming line ends.” Leave all other check boxes in their default state.
4. Power on the power supply and allow the power supply to perform its initialization. In HyperTerminal™, tap the ENTER key a couple of times to clear the input buffer
NOTE: tapping the ENTER key is also required to clear any errors when using HyperTerminal™, rather than tapping the BACKSPACE or DELETE keys.
5. Set the IP address by typing **SYST:NET:IP “xxx.xxx.xxx.xxx”** <enter> (where xxx.xxx.xxx.xxx is the new IP address). For example, to set 192.168.0.200 as the IP address, type SYST:NET:IP “192.168.0.200” <enter>
NOTE: the format requires a single space after SYST:NET:IP and double quotes around the IP address numbers.
6. Set the subnet mask with **SYST:NET:MASK xxx.xxx.xxx.xxx** <enter>.
7. After configuring all settings, verify with the queries, **SYST:NET:IP?** <enter> and **SYST:NET:MASK?** <enter>.
8. Type ***RST**<enter> to perform a power–on reset of the power supply.
9. The SG Ethernet hardware is now configured. Open your Web browser and enter the assigned IP address of the power supply to view the power supply web page.
10. The power supply is now ready to be plugged into the network.

5.2.4 Network Setup Using Web Browser

Note: This requires that the PC’s IP address be in the same network as the IP address assigned to the power supply. It also requires your Web browser to open the power supply’s Home page.

Note: For proper functionality on the Web browser, ensure that Sun Microsystems’ *Java Runtime Environment* is installed on the PC. Visit www.java.com to download, after setting the Web browser’s Security to enable scripting of Java applets:

1. In the Tools menu, select Internet Options... and click the Security tab.
2. At the bottom of the Security window click Custom level...
3. In the Reset custom settings drop-down, select Medium and click Reset and then OK).
4. Now use your Web browser for Network Setup:
In the Web browser’s Address: field, type xxx.xxx.x.xxx where xxx.xxx.x.xxx is the power supply’s IP address. (See Section 5.4.3 for description and operation information).

5.2.5 Configuration Switch

Use the DIP switch (will have either four or eight switches and is accessible from the rear panel) to configure the power supply with the installed Ethernet interface adapter. The following figures show the DIP switch configuration for the Ethernet connection. On the Ethernet master, set the rear panel switch to Remote On, and disregard all remaining switches.

Note: There is one of two types of DIP switches: toggle or rocker. For **toggle** switches, the shading indicates the position of the toggle switch. For **rocker** switches, the shading indicates the depressed side.

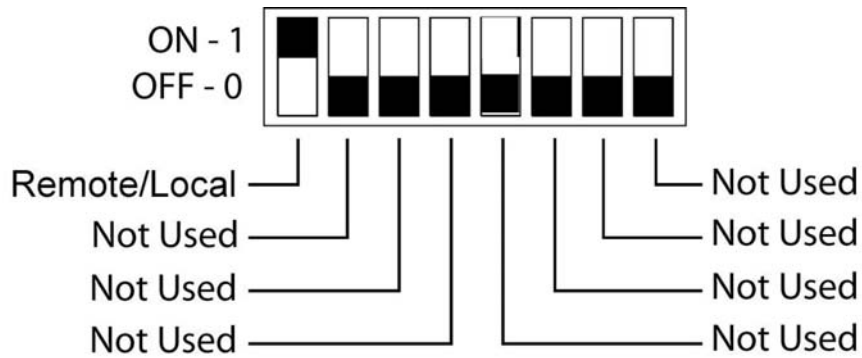

Figure 5-5. SG 8-pin Configuration Switch for the Ethernet Option

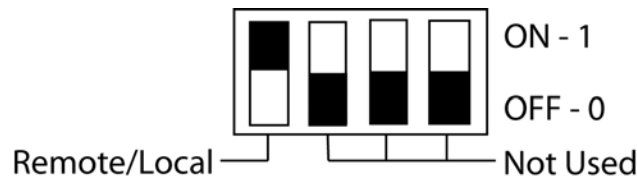

Figure 5-6. SG 4-pin Configuration Switch for the Ethernet Option

5.2.6 Remote/Local Selection

Set the rear panel Remote/Local switch to select remote or local operation.

Remote ON switch (rocker) is top depressed.

Table 5-1. Remote/Local Switch

Switch Position	Description
ON	Remote operation selected.*
OFF	Local operation selected, and front panel control is enabled. NOTE: Unit will switch to remote operation upon issuing the first Ethernet or RS232 non-query command.

- * In the ON position, the power hardware and Ethernet card initialize to the remote state at power-on.

When in remote operation, the front panel control remains disabled regardless of the state of the REN (Remote ENable) line, or the GTL (Go To Local) command.

To revert to front panel control, use the special command **SYST:LOCAL** <on/off>.

Powering up in remote mode will result in the operating conditions described in Table 5-2.

Table 5-2. Remote Mode Power-on Conditions

Condition	Default
Voltage	0 Volts (initial from factory power-on voltage); otherwise, last value saved by SCPI command or by the SAVE SETTINGS button in the Web Settings page. See CAL:INIT:VOLT to change.
Current	0 Amps (initial from factory power-on current); otherwise, last value saved by SCPI command or by the SAVE SETTINGS button in the Web Settings page. See CAL:INIT:CURR to change.
Soft Voltage Limit	Model maximum voltage *
Soft Current Limit	Model maximum current *
OVP Trip Voltage	Model maximum voltage +10% (initial from factory power-on OVP); otherwise, last value saved by SCPI command or by the SAVE SETTINGS button in the Web Settings page. See CAL:INIT:VOLT:PROT to change.
Delay	0.5 seconds
Foldback Protection	OFF (non-configurable)
Output	ON ** See CAL:MOD:POWERON
Hold	OFF
Unmask	NONE
Service Request Capability	OFF

* User-programmable temporary limit (reverts to power-on defaults after power cycle or Reset command is issued).

** User-selectable

5.3 EXTERNAL USER CONTROL SIGNAL CONNECTOR

A10-pin Molex connector (Figure 5-7) located at the rear panel provides external auxiliary control signals to increase the user's operating control of the supply. The mating receptacle is Molex 43025-1000 with 10 female terminals. The Molex terminals accommodate wire sizes from #20 - #24.

The relay outputs, when active, connect the POLARITY, ISOLATION and SENSE pins (Pins 6, 7 and 8) of the connector to the relay COMMON pin (Pin 5). The relays are rated at 120VAC/125VDC @ 1A. Any change in output (voltage, current, etc.) initiated by the user from the RS232, GPIB, or Ethernet interface, will generate a 10ms synchronization pulse at the rear panel User Control Signal Connector of the unit (TRIGGER OUT).

Table 5-3. External User Control Signal Connector Pinout – Ethernet only

Designator (Pin)	Schematic Symbol	Functional Description	Electrical Characteristics
1	FOLDBACK	Output signal, open collector, active-low. Asserted when in foldback mode. Emitter is on pin 9. (See OUTPUT:PROT:FOLD command in the Output SCPI Command Subsystem, Section 6.7 of this manual).	Max 60 VDC Max 4 mA DC
2	SHUTDOWN	Open anode (1k resistor on-board) input signal. Allows the user to immediately shutdown the unit by presenting a 10-20 mA input signal. Cathode on pin 9.	Max 12 VDC Max 6 VDC reverse voltage
3	FAULT	Output signal, open collector, active-low. Asserted when a fault is recorded in the fault register. Emitter is on pin 9.	Max 60 VDC Max 4 mA DC
4	TRIGGER OUT	Synchronize output signal, open collector, active-low. Pulsed for 10 ms when a change in the output occurs. Emitter is on pin 9.	Max 60 VDC Max 7 mA DC
5	COMMON	For all relay contacts. Optionally connected to pin 9 by internal jumper	
6	POLARITY	Output signal, relay contacts. Asserted (contacts close to COMMON) when a negative voltage is programmed. (e.g., SOURCE:VOLTage -5.0)	Max 2 ADC Max 30 VDC Max 60 W
7	ISOLATION	Output signal, relay contacts. Asserted (contacts close to COMMON) when the output relay is programmed OFF. (e.g., OUTPUT:ISOLation OFF)	Max 2 ADC Max 30 VDC Max 60 W
8	SENSE	Output signal, relay contacts. Asserted (contacts close to COMMON) when the sense relay is programmed OFF. (e.g., OUTPUT:SENSe OFF)	Max 2 ADC Max 30 VDC Max 60 W
9	ISO COMMON	Opto-isolator common line.	
10	TRIGGER IN	Hardware - Open Anode (1k resistor on-board) of opto-isolator. Cathode on pin 9. This signal is provided for external hardware triggering of sequence functions and of voltage and current ramp functions.	Max 12 VDC Max 6 VDC reverse voltage

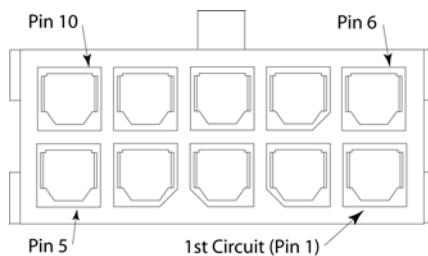

Figure 5-7. External User Connector (rear panel view) Designation (10-pin Molex)

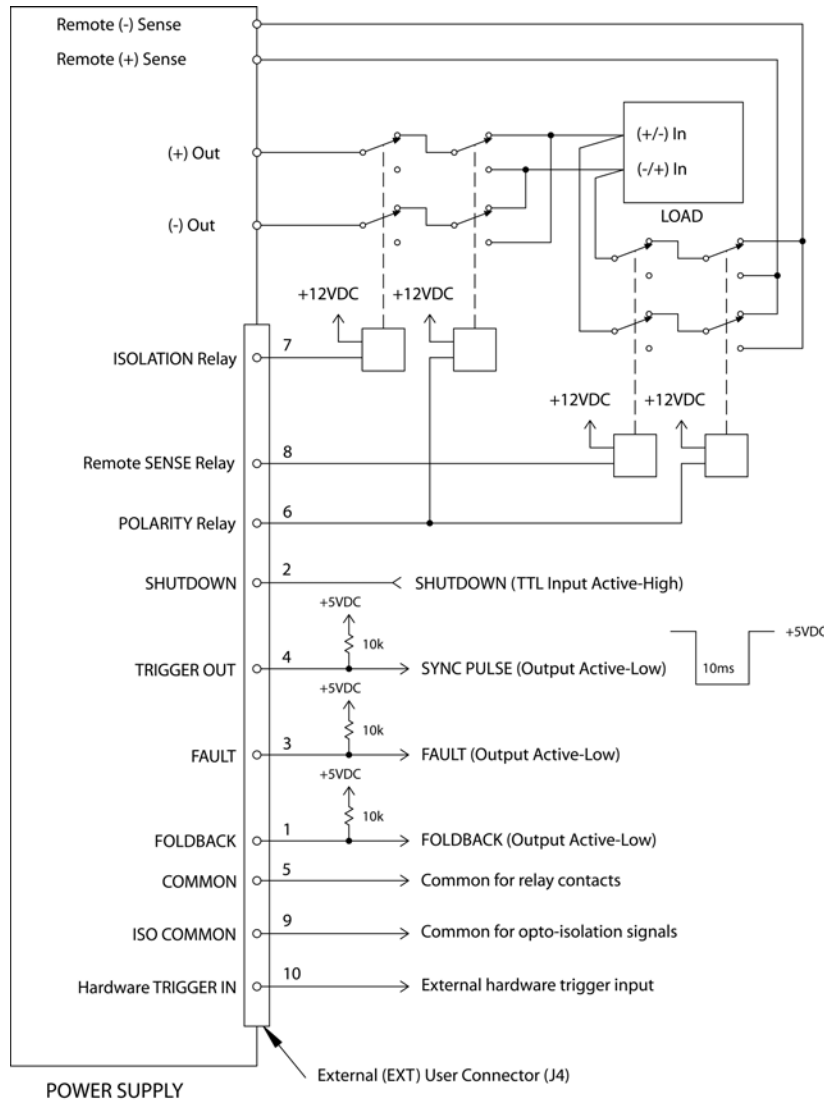

Figure 5-8. Example of Open Collector, TTL Input, and Relay Output Circuits



CAUTION

External relays must not be hot-switched; ensure that the voltage across the relay contacts and the current through them is zero prior to changing the relay states.

5.4 PROGRAMMING/COMMUNICATION VIA ETHERNET

With the Ethernet option, there are four basic methods to communicate with the power supply from a PC:

- raw socket interface, sending delimited strings (default delimiter is <LineFeed>)
- application program that utilizes VXI-11 Discovery protocol
- Web browser (Internet Explorer 6 or higher or compatible) and the internal Web server, with scripting of Java applets enabled
- RS232C serial interface

5.4.1 Raw Socket Interface

The essential components of communicating via a raw socket interface are the socket number, IP address and command delimiter. The default values are: socket = 9221, IP address = 192.168.0.200 (when static IP is enabled), and delimiter = line feed <LF>. All of these items may be changed via either the Web browser (see IP CONFIGURATION, Section 5.5.2) or the RS232C interface (see System SCPI command, Section 6.9).

For convenience and to comply with the proposed LXI™ standard, the VISA resource name is available on the home page of the power supply's Web server.

5.4.2 VXI-11 Protocol

With programs such as National Instrument's NI-VISA, the VXI-11 protocol allows the power supply to be easily configured in a test system.

5.4.3 Web Server

To communicate with the power supply via the built-in Web server, open a supported Web browser (Internet Explorer 6.0 or higher or compatible) and type the IP address of the power supply in the "Address" field. Tap the ENTER key to launch the power supply's Ethernet Web page interface.

Note: *To ensure proper functionality on your Web browser, Sun Microsystems' Java Runtime Environment must be installed on your PC. Visit www.java.com to download. Also, set your Web browser's Security to enable scripting of Java applets. (In the Tools menu, select Internet Options... and click the Security tab. At the bottom of the Security window click Custom level...; in the Reset custom settings drop-down, select Medium and click Reset and then OK).*

5.5 ETHERNET WEB PAGES, OVERVIEW

The layout of each of the Web pages includes the banner with the heading, “Sorensen SGI (or SGA) Power Supply Interface” along with the device name below and a LOGIN button to the right. Below the SGI banner are eight tabs (six tabs in the SGA banner), each linked to its corresponding page. On each page is a title line (title matches tab name). In the title line is an area that frequently displays informational messages (when warranted) as you use the Web interface, such as a confirmation message or an error message.



Figure 5-9. SGI Banner and Tabs



Figure 5-10. SGA Banner and Tabs

Note: There are few differences between the SGA interface and the SGI interface: their titles and device names in the banner, their specifics in the Home page, and SGI has two pages that are not included in the SGA: Power and Presets. Unless SGA and SGI interfaces are both shown, most illustrations use only the SGI interface.

When navigating to the Ethernet Web pages by clicking their tabs, you will find that only the HOME page (default) may be accessed without logging in. You must log in (click LOGIN) before tabbing to the other pages, which allow access by permission only: FULL (Administrator), RW (Read\Write), or R (Read).

- **FULL** permissions users have access to all pages and all channels and may configure the interface, set and change security settings, allocate channels, control the output of the power supply, send commands, etc.
- **RW** permissions users may access all pages except SECURITY, and may read and control the output of the power supply for only the channels allocated to them. They are not authorized to make changes on the IP CONFIGURATION page.
- **R** permission users may read information related only to the channels allocated them, and cannot make any changes or control the output.



The screenshot shows a web-based login interface for a Sorensen SGI Power Supply. At the top left is the 'epec' logo with 'Elgar Electronics Corp.' underneath. To the right of the logo, the text reads 'Sorensen SGI Power Supply Interface' in a large, bold font, followed by 'DEVICE:LXI-Sorensen-SGI330/45C-1CAAM130' in a smaller font. Below this, the word 'LOGIN:' is displayed above a horizontal line. In the center of the page, there are two input fields: 'User ID:' followed by a text box, and 'Password:' followed by a text box. Below these fields are two buttons: 'SUBMIT' and 'CANCEL'. At the bottom left of the interface, there is a small copyright notice: '© 2005 Elgar Electronics Corporation'.

Figure 5-11. Login Window

Once you have logged in, the LOGIN button becomes a LOGOUT button.

5.5.1 HOME

This is the default, information-only page. It displays all of the current information about the supply that you are connected to:

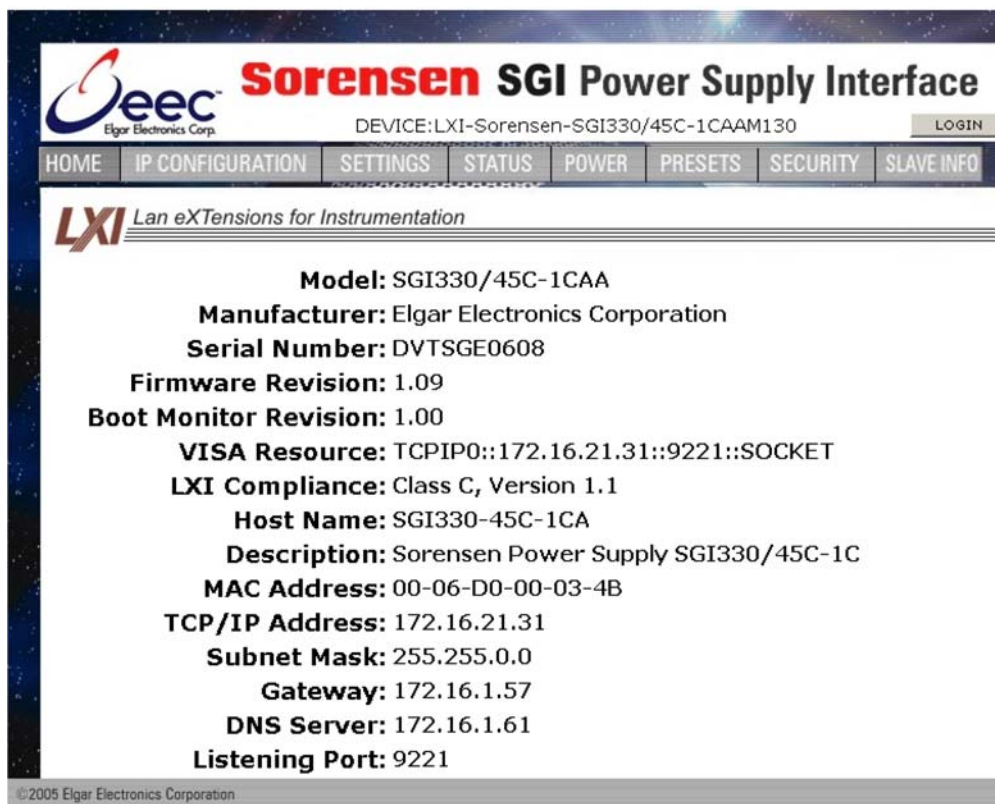

The screenshot shows the Sorenson SGI Power Supply Interface web page. At the top, there is a header with the 'epec' logo (Elgar Electronics Corp.) and the title 'Sorenson SGI Power Supply Interface'. Below the title, the device ID is 'LXI-Sorenson-SGI330/45C-1CAAM130' and there is a 'LOGIN' button. A navigation menu contains links for HOME, IP CONFIGURATION, SETTINGS, STATUS, POWER, PRESETS, SECURITY, and SLAVE INFO. The main content area features the LXI logo and the tagline 'Lan eXTensions for Instrumentation'. Below this, a list of system parameters is displayed:

- Model:** SGI330/45C-1CAA
- Manufacturer:** Elgar Electronics Corporation
- Serial Number:** DVTSGE0608
- Firmware Revision:** 1.09
- Boot Monitor Revision:** 1.00
- VISA Resource:** TCPIP0::172.16.21.31::9221::SOCKET
- LXI Compliance:** Class C, Version 1.1
- Host Name:** SGI330-45C-1CA
- Description:** Sorenson Power Supply SGI330/45C-1C
- MAC Address:** 00-06-D0-00-03-4B
- TCP/IP Address:** 172.16.21.31
- Subnet Mask:** 255.255.0.0
- Gateway:** 172.16.1.57
- DNS Server:** 172.16.1.61
- Listening Port:** 9221

At the bottom left of the page, there is a copyright notice: '© 2005 Elgar Electronics Corporation'.

Figure 5-12. SGI Home Page

- The **Model** number, the **Manufacturer**, and the **Serial Number** of your Ethernet power supply
- **Firmware Revision:** the version of the Ethernet firmware that is currently installed.
- **VISA Resource** identifies the specific resource name used to communicate via VISA (Virtual Instrument Software Architecture)
- **LXI™ Compliance:** the version and instrument class of the LXI™ standard with which your power supply is compliant
- **Host Name:** either the default or user-defined, network-unique identity (Must be limited to 15 characters or less for LXI compliance).
- **Description:** either the default or user-defined description of the power supply in use (you can change the description to suit your needs, in the CONFIGURATION page, but it must be limited to 36 characters)
- **MAC Address:** the power supply Ethernet's unique hardware address

- **IP Address:** your power supply's address actually in use at start-up; can be statically configured, DHCP acquired (default), or Auto-IP assigned (see description for CONFIGURATION page)
- **Subnet Mask:** network segment your power supply is on
- **Gateway:** IP address through which the instrument communicates with systems that are not on the local subnet
- **DNS Server:** IP address of the Domain Name System (DNS) server
- **Listening Port:** port number for the embedded Web server

5.5.2 IP CONFIGURATION

Only users with FULL permissions shall have access to this Web page and be allowed to configure the interface. You are only required to complete the information for the parameters that you wish to change; all previously entered and saved information remains by default.

The screenshot displays the 'IP CONFIGURATION' page of the Sorensen SGI Power Supply Interface. At the top, there is a navigation bar with buttons for HOME, IP CONFIGURATION, SETTINGS, STATUS, POWER, PRESETS, SECURITY, and SLAVE INFO. The page title is 'Sorensen SGI Power Supply Interface' and the device ID is 'LXI-Sorensen-SGI330/45C-1CAAM130'. The 'IP CONFIGURATION' section includes the following fields and options:

- Host Name:** SGI330-45C-1CA
- Description:** Sorensen Power Supply SGI330/45C
- TCP/IP Primary Configuration:**
 - Use a Static IP Address
 - Obtain an IP Address Automatically
 - Auto IP Enabled
- TCP/IP Secondary Configuration:**
 - Use a Static IP Address
 - Obtain an IP Address Automatically
 - Auto IP Enabled
- IP Address:** 192 . 168 . 0 . 200
- Subnet Mask:** 255 . 255 . 255 . 0
- Gateway:** 0 . 0 . 0 . 0
- DNS Server:** 0 . 0 . 0 . 0
- Listening Port:** 9221

An 'APPLY' button is located at the bottom of the configuration section. The footer of the page reads '©2005 Elgar Electronics Corporation'.

Figure 5-13. SGI IP Configuration Page

Host Name: the default name includes the base model number of your power supply, with the last four digits of the serial number. You may change this name as long as it is unique (Host Name must be limited to 15 characters for LXI compliance) so that VXI-11 Discovery and any other IP Discovery program can identify your specific device on your network.

To change: Type the new name (15 characters maximum) in the blank field provided and click **Apply** to update (or make all desired changes before clicking **Apply**).

Description: you may change the default factory setting to something more meaningful to your current setup.

To change: Type your customized description, up to 36 characters, in the blank field provided, and click **Apply** to update (or make all desired changes before clicking **Apply**).

TCP/IP Configuration: the power supply has two TCP/IP configurations that can be set, Primary and Secondary. If the Primary Configuration is not valid on your network, the power supply will attempt to try the Secondary Configuration.

NOTE: The power supply will NOT try the Secondary Configuration if you have selected the Primary Configuration options, **Obtain an IP Address Automatically** and **Auto IP Enabled**.

You may statically assign an IP address as well as configure other Ethernet/LAN parameters, or you may keep/return to its default setting for automatic assignment of an IP address.

To assign: Click the radio button next to **Use a Static IP Address** to manually configure some or all of the following the Ethernet/LAN parameters:

IP Address – input any standard IP address. (Factory setting is 192.168.0.200). After clicking **Apply**, you also must reset the power supply and then exit and restart the Web browser to effect this change. If you have changed the network portion of the IP address, it may be necessary to alter the network settings of your attached computer to reconnect to the power supply.

Subnet Mask – input a value that identifies which network segment your power supply is on, consisting of 4 whole numbers, each ranging from 0 through 255, separated by periods. (Factory setting is 255.255.255.0, a class-C network subnet mask). Click **Apply** to update (or make all desired changes before clicking **Apply**).

Gateway – input the IP Address of any gateway that stands between the instrument and any other network entities that communicate with the power supply. (No factory setting). Click **Apply** to update (or make all desired changes before clicking **Apply**).

DNS Server – input an IP address for the Domain Name System (DNS) server. Click **Apply** to

update (or make all desired changes before clicking **Apply**). This field has no factory setting.

Listening Port – input a port number for the embedded Web server, ranging in value from 1025 – 65535. Click **Apply** to update (or make all desired changes before clicking **Apply**). The factory default port number is 9221.

To automate: (To return to the default setting): Click the radio button next to **Obtain an IP Address Automatically** for dynamic address acquisition from the DHCP server.

Auto IP Enabled: allows the power supply to assign itself an IP address in the range from 169.254.0.1 to 169.254.255.254 with a subnet mask of 255.255.0.0. If it is enabled, when there is no DHCP server available, the power supply will assign itself an IP address. However, please keep in mind that when you select **Obtain an IP Address Automatically** and you check **Auto IP Enabled** in **TCP/IP Primary Configuration**, the system will not try the Secondary Configuration.

To enable: Click in the box to check; click again to uncheck so that it is no longer enabled.

Example TCP/IP Configurations:

Primary: Use a Static IP Address

Secondary: Obtain an IP Address Automatically (DHCP)

At power-up the power supply will assign itself the configured static IP address. If no other device is using the IP address, the power supply continues with that static IP address. If some other device is using that address, the power supply will move to Secondary and attempt to acquire an IP address from a DHCP server repeatedly until it gets an address.

Primary: Use a Static IP Address

Secondary: Obtain an IP Address Automatically (DHCP) and AutoIP Enabled

At power-up the power supply will assign itself the static IP address. If no other device is using the IP address, the power supply continues with that static IP address. If some other device is using that address, the power supply will move to secondary and attempt to acquire an IP address from a DHCP server. If it cannot find a DHCP server to assign an address, it will assign itself a link-local address. If no other device is using that link-local address it will use it for 5 minutes minimum. At that time, if it is already in communication with some other device, it will hold onto that link-local address until the communication is finished and then retry DHCP. Then, if DHCP is not available, the power supply will revert to the last successful link-local address for another 5 minutes minimum.

Primary: Obtain an IP Address Automatically (DHCP) and AutoIP Enabled**Secondary:** no matter the setting, will never be attempted

At power-up the power supply will attempt to acquire an IP address from a DHCP server. If it cannot find a DHCP server to assign an address, it will assign itself a link-local address. If no other device is using that link-local address, it will use it for 5 minutes minimum. At that time, if it is already in communication with some other device, it will hold onto the link-local address until the communication is finished and then retry DHCP. If DHCP is not available, the power supply will revert to the last successful link-local address for another 5 minutes minimum.

Primary: Obtain an IP Address Automatically (DHCP)**Secondary: Use a Static IP Address**

At power-up the power supply will attempt to acquire an IP address from a DHCP server. If it cannot find a DHCP server to assign an address, the power supply will move to Secondary and assign itself the static IP address. If no other device is using the IP address, the power supply continues with that static IP address. If some other device is using the static IP address, the power supply will move back to Primary and start the entire operation again.

5.5.3 SETTINGS

The Settings page is available to users who have FULL, Read/Write or Read Only access to at least one power supply (Read Only users can make no changes to the settings). In this page you will see continuous updates (2-5 times per second) of the actual voltage output (value displayed on the left) and the actual live current output (value displayed to the right).

The screenshot displays the 'SETTINGS' page of the Sorensen SGI Power Supply Interface. At the top, the Elgar Electronics Corp. logo and 'Sorensen SGI Power Supply Interface' title are visible, along with the device ID 'LXI-Sorensen-SGI160/94C-1CAAM130' and a 'LOGOUT' button. A navigation bar contains links for HOME, IP CONFIGURATION, SETTINGS (active), STATUS, POWER, PRESETS, SECURITY, and SLAVE INFO. The main content area is titled 'SETTINGS:' and features a large 'LXI' logo on the right. On the left, three large green digital displays show '0.000' (Voltage), '0.018' (Current), and '0.00' (OVP). Below these are input fields for 'Set V' (50.00), 'Set I' (0.00), and 'Set OVP' (176.00), with an 'APPLY' button. To the right, radio buttons indicate the operating mode: 'CV' (checked) and 'OUTPUT'. Further right, a 'Output' section contains buttons for 'CLEAR OVP', 'CLEAR FAULT', 'OUTPUT', 'FRONT PANEL LOCKOUT', and 'INSTRUMENT ID'. At the bottom of the settings section are 'RECALL SETTINGS' and 'SAVE SETTINGS' buttons. Below this is a 'SCPI Command History' section with a text input field, 'SEND COMMAND', 'SEND AND READ', and 'CLEAR RESPONSES' buttons. The footer shows '©2005 Elgar Electronics Corporation'.

Figure 5-14. Settings Page

Voltage: value above is updated with actual voltage output of the power supply

Current: value above is updated with actual live current output

Set V: the programmed voltage setting

Set I: the programmed current setting

Set OVP: the programmed over voltage protection setting

APPLY: puts into effect the newly input settings

CC and CV indicators: presently operating output mode of the power supply, either constant voltage or constant current.

OVP indicator: highlighted red if over voltage protection is activated

FAULT indicator: highlighted red if fault has occurred

OUTPUT indicator: solid-lit shows power output status is On

If you have **Read/Write** access, you can change the following settings (after inputting desired settings, click **APPLY**):

- **Set V** – click in the Set V field and input a new value for voltage.
- **Set I:** click in the Set I field and input a new value for current.

Set OVP: click in the Set OVP field and input a new value for over voltage protection.

Output – click the applicable button(s) as follows:

CLEAR OVP: to clear the OVP indication/condition after clearing the cause of the event. The power supply will revert to the last saved values for Voltage, Current, and OVP. Be sure to reset these values, if desired, before clearing an OVP condition.

CLEAR FAULT: to clear the hardware fault indication/condition after clearing the cause of the event.

OUTPUT: to turn on or off the power output (see Output indicator)

FRONT PANEL LOCKOUT: to prevent or enable changes being made via the front panel (LED to the left is lit when Lockout is in effect).

- **INSTRUMENT ID:** click to identify which power supply (instrument) in a rack of equipment corresponds to the Channel selected. The LED to the left of this button indicates whether or not this function is turned on (ON causes the instrument's rear panel NET LED to flash; the flashing continues until you click **INSTRUMENT ID** again).

Power-on Default: click the applicable button(s) as follows:

- **RECALL SETTINGS:** click to restore the programmed Power-on defaults into the Set V, Set I and Set OVP settings, and to the power supply output (these defaults are those that were last saved prior to this Power-on).
- **SAVE SETTINGS:** after clicking **APPLY**, click **SAVE SETTINGS** to save the presently set values displayed in the Set V, Set I and Set OVP fields into non-volatile flash. (If only one new setting had been input, the other previously saved values remain the same).
Be aware that these then become the new power-on settings that will be applied at power-up time and after OVP reset as described in “Clear OVP” above.

NOTE: When you click **SAVE SETTINGS**, you will get a pop-up alert (Figure 5-15) telling you that saving a non-zero voltage may cause the power supply to power-on with a voltage on its output terminals after a restart or power cycle.



Figure 5-15. Alert Message for Save Settings

SCPI COMMAND SECTION:

SEND COMMAND: (not to be used with any command that provides a response) input a properly formatted SCPI command (Section 6) in the upper of the two windows and click this button to send the command.

SEND AND READ: for queries, input a properly formatted SCPI query command in the upper of the two windows, and click this button to send the command and read the response in the lower of the two windows.

SCPI Command History: a history of the last few commands sent to the power supply are remembered by the system and listed in this area. You can click on a command to have it be pasted in the command window.

CLEAR RESPONSES: click this button to clear the response window of previous responses.

5.5.4 STATUS

The Status page displays updated information for the following parameters:

Deec Sorensen SGI Power Supply Interface
Elgar Electronics Corp. DEVICE: LXI-Sorensen-SGI330/45C-1CAAM130 LOGOUT

HOME IP CONFIGURATION SETTINGS STATUS POWER PRESETS SECURITY SLAVE INFO

STATUS: LXI

Output: OFF **OVP:** OK
Trigger: OFF **Fault:** OK

Command Error:

Last Calibration Date: 07/26/2006
Next Calibration Date: 07/26/2007
Ping Echo: ON OFF

Ping Remote IP Address:

Response:

©2005 Elgar Electronics Corporation

Figure 5-16. Status Page

Output: displays the power output status, ON or OFF

Trigger: set up by SCPI commands, displays whether the Trigger state is OFF, ARMED, or TRIGGERED.

OVP: displays Read Only status of over voltage protection, either OK (normal) or TRIPPED.

FAULT: displays Read Only status of over temperature condition, either OK (normal) or TRIPPED.

Command Error: displays command and syntax errors that are queued in the supply.

READ NEXT ERROR: each click brings the next error into the Command Error display, until no other errors are in the queue.

CLEAR MESSAGES: click this button to clear the Command Error message window of past messages.

Last Calibration Date: displays the date that the power supply (instrument) was last calibrated; configurable with SCPI commands, normally at the time of calibration.

Next Calibration Date: displays the date that the power supply should be calibrated next; also configurable with SCPI commands, normally calculated at time of calibration.

Ping Echo: except for Read Only users, allows turning echo ability On or Off, depending on whether or not you want the supply to respond to a Ping command from another device on the network. The default setting for Ping Echo is response enabled. Click the OFF radio button if you do not want the supply to respond to a ping.

Ping Remote IP Address: allows you to input an IP address of another device in the system

Ping: click this button to ping the device at the address that you entered in the **Ping Remote IP Address** field.

Response: displays the result of your ping. For Example, if the Ping Address were 69.36.230.190, the Response window would display:

Pinging :69.36.230.190 Response Took 0 ticks

Or

Ping Failed (if the host specified is not in the network)

CLEAR RESPONSES: click this button to clear the Response window of past ping responses.

5.5.5 POWER

The Power page (only in SGI) displays updated information for the following parameters:

The screenshot displays the Sorenson SGI Power Supply Interface. At the top, it shows the 'eegc' logo and 'Sorenson SGI Power Supply Interface'. The device ID is 'LXI-Sorenson-SGI160/94C-1CAAM130'. A navigation bar includes 'HOME', 'IP CONFIGURATION', 'SETTINGS', 'STATUS', 'POWER', 'PRESETS', 'SECURITY', and 'SLAVE INFO'. The 'POWER' section shows real-time values: 0.000 Volts, 0.018 Current, and 0.00 Power (kW). Status indicators include CC, OVP, FAULT, CV, and OUTPUT. A control panel allows setting Max Volts (50.00), Max Current (0.00), Max Watts (0.0), Stop Volts (0.00), Stop Current (0.00), and Stop OVolt (176.00). Buttons for 'EXECUTE/UPDATE' and 'STOP' are present.

Figure 5-17. SGI Power Page (not in SGA)

Volts: value above is updated with actual voltage output of the power supply

Current: value above is updated with actual live current output of the power supply

Power (kW): value above is updated with actual power output of the power supply

Max Volts: the programmed voltage setting limit

Max Current: the programmed current setting limit

Max Watts: the programmed power setting limit

EXECUTE/UPDATE: puts into effect the newly programmed limits

Stop Volts: the programmed voltage setting when you exit power mode

Stop Current: the programmed current setting when you exit power mode

Stop OVolt: the programmed overvoltage setting when you exit power mode

STOP: puts into effect the newly programmed settings and exits power mode

CC and CV indicators: presently operating output mode of the power supply, either constant voltage or constant current.

OVP indicator: highlighted red if over voltage protection is activated

FAULT indicator: highlighted red if fault has occurred

OUTPUT indicator: solid-lit shows power output status is On

If you have Read/Write access, you can change the following settings (after inputting desired settings, click **EXECUTE/UPDATE**):

- **Max Volts:** click in the Max Volts field and input a new value for voltage.
- **Max Current:** click in the Max Current field and input a new value for current.
- **Max Watts:** click in the Max Watts field and input a new value for power.

If you have Read/Write access, you can change the following settings (after inputting desired settings, click **STOP**):

- **Stop Volts:** click in the Stop Volts field and input a new value for voltage.
- **Stop Current:** click in the Stop Current field and input a new value for current.
- **Stop OVolt:** click in the Stop OVolt field and input a new value for overvoltage protection.

5.5.6 PRESETS

The Presets page (only in SGI) displays stored values, which can be edited, saved and/or recalled. The parameters for this page are:

Index	Volts	Current	Over Volt	Output State		
POWER ON	0.00	0.00	0.00	○	SAVE	EXECUTE
1	0.00	0.00	363.00	○	SAVE	EXECUTE
2	0.00	0.00	0.00	○	SAVE	EXECUTE
3	0.00	0.00	0.00	○	SAVE	EXECUTE
4	0.00	0.00	0.00	○	SAVE	EXECUTE
5	0.00	0.00	0.00	○	SAVE	EXECUTE
6	0.00	0.00	0.00	○	SAVE	EXECUTE
7	0.00	0.00	0.00	○	SAVE	EXECUTE
8	0.00	0.00	0.00	○	SAVE	EXECUTE
9	0.00	0.00	0.00	○	SAVE	EXECUTE

Figure 5-18. SGI Presets Page (not in SGA)

Index: Displays memory locations named POWER ON (default power on settings) and 1 through 9

Volts: value presently stored in memory location name

Current: value presently stored in memory location name

Over Volt: value presently stored in memory location name

Output State: displays state of the output condition presently stored in memory location name (indicator is an open circle for OFF or a solid circle for ON)

SAVE: saves the input values into their respective location name memory (Must have Read/Write access)

EXECUTE: recalls the following settings into operation from its respective memory location name (Must have Read/Write access)

If you have Read/Write access, you can save the following settings into its respective memory location name (after inputting desired settings, click **SAVE**):

- **Volts:** click in the Volts field and input a new value for voltage.
- **Current:** click in the Current field and input a new value for current.

- **Over Volt:** click in the Over Volt field and input a new value for overvoltage protection.
- **Output State:** click in the Output State field to change the state of the output condition indicator. (indicator is an open circle for OFF or a solid circle for ON)

5.5.7 SECURITY

Accessible only if you have Administrative (Full) rights, this page allows you to set up new user accounts for access to the power supply(s). It displays all of the currently set up users and respective permission levels.

- FULL = full rights/Administrator
- RW = read and write to power supply(s)
- R = Read Only
- -L = identifies user currently logged onto a power supply session.

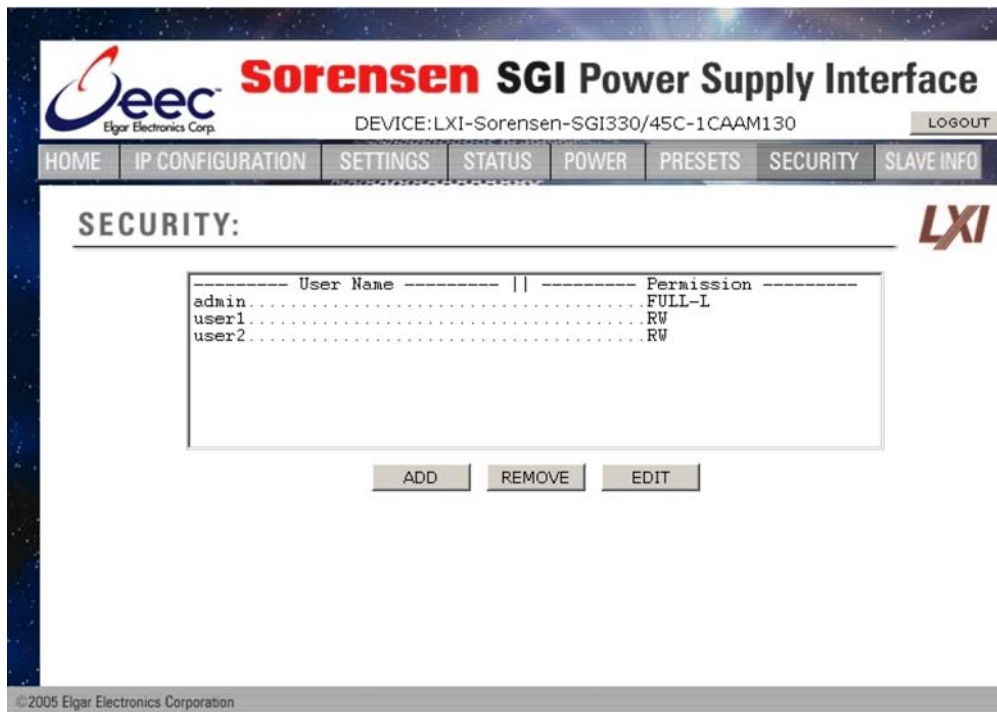

Figure 5-19. Security Page

ADD: Click to pull up a separate page in which to input new users with passwords and permission levels. (See Figure 5-20).

REMOVE: Click to delete selected user after first highlighting their User Name row. The Admin user cannot be removed.

EDIT: Click to change settings (name/permissions) for selected user after first highlighting their User Name row. This brings up the Edit Existing User window (Figure 5-21).

ADD NEW USER

Accessible from the Security Page by clicking the ADD button, this page allows you (a Full permissions user) to add new users with their passwords and permission levels.

Figure 5-20. Add New User Window from Security Page

- To add:
1. Input appropriate information in **User ID** (case-sensitive, limited to 14 characters), in **Password** (case sensitive, limited to 9 characters), and in **Re-enter Password** fields.
 2. Select permission level from the **Permission** dropdown.
 3. To accept into the system, click **SUBMIT** or tap the ENTER key.

In the ADD NEW USER: line, you will see a message that [new user name] was added successfully, or a message that it was unsuccessful and the reason.

RESET: click to clear the fields where you input information.

CANCEL: click to return to the Security page; a message displays verifying that the Add New User was cancelled. This button does NOT “undo” previous successful submit operations.

EDIT EXISTING USER

Accessible from the Security Page by clicking the EDIT button after first selecting the user's name, this page allows you (a Full permissions user) to edit the parameters for an existing user.

The screenshot shows the 'EDIT EXISTING USER' window in the Sorensen SGI Power Supply Interface. The window title is 'EDIT EXISTING USER:'. Below the title, there are three input fields: 'User ID' with the value 'user1', 'Password' with masked characters '....', and 'Re-enter Password' with masked characters '....'. To the right of these fields is a 'Permission' dropdown menu currently set to 'R'. At the bottom of the form are three buttons: 'SUBMIT', 'CANCEL', and 'RESET'. The interface also features a top navigation bar with buttons for 'HOME', 'IP CONFIGURATION', 'SETTINGS', 'STATUS', 'POWER', 'PRESETS', 'SECURITY', and 'SLAVE INFO'. The device information 'DEVICE:LXI-Sorensen-SGI330/45C-1CAAM130' and a 'LOGOUT' button are visible in the top right corner.

Figure 5-21. Edit Existing User Window from Security Page

When this page appears, the fields are populated with the selected user's existing parameters.

- To edit:
1. Input appropriate information, as desired, in **User ID** (case-sensitive, limited to 14 characters), in **Password** (case sensitive, limited to 9 characters), and/or in **Re-enter Password** fields.
 2. Select permission level from the **Permission** dropdown.
 3. To accept into the system, click **SUBMIT** or tap the ENTER key.

If your edit was successful, you will return to the Security page with a message to that effect.

If there is an error in the editing process, you will stay in the Edit Existing User page, and you will see a message in the EDIT EXISTING USER: line, describing the reason for the error.

- **RESET**: click to clear the fields where you input information.
- **CANCEL**: click to return to the Security page; a message displays verifying that the User Edit was cancelled. This button does NOT “undo” previous successfully submitted operations.

SECTION 6

IEEE 488.2 GPIB/RS232/ETHERNET AND SCPI COMMAND OPERATION

6.1 INTRODUCTION

This section describes the operation of the Digital Interface Adapter (DIA) for both GPIB and Ethernet, by using the IEEE 488.2, Ethernet and SCPI command sets, which provide programming, query, and status commands that facilitate remote control of the power supply.

6.2 REGISTER DEFINITIONS

The applicable DIA (for either GPIB or Ethernet) supports the IEEE 488.2 GPIB, Ethernet and SCPI 1995.0 status reporting data structures. These structures are comprised of status registers and status register enable mask pairs. The following sections describe these pairs.

6.2.1 SCPI Status Byte

The SCPI Status Byte registers the status of the instrument, in one of seven bits described in Table 6-1. Read the SCPI Status Byte status register by issuing either the *STB? command or a serial poll. Clear the Status Byte status register by issuing the *CLS command.

Configure the DIA to request service from either the GPIB or Ethernet controller, by setting the appropriate bits in the Service Request Enable Register (SRE), which has the same bit pattern as the Status Byte. Modify the SRE register by issuing the *SRE <mask> command, and read the SRE register by issuing the *SRE? command. For example, if the SRE register is set to 0x10 (MAV), when the DIA unit has a message available, the Status Byte register will contain 0x50 (RQS and MAV) and the SRQ (SRQ is supported only on GPIB; not Ethernet or RS232) line will be asserted to indicate a request for service. See Table 6-1 and refer to **SCPI Status Implementation**, page 8-1, for further information.

Table 6-1. SCPI Status Byte

Bit	Hex Value	Description
0	0x01	Not used.
1	0x02	Protection Event Status flag. Indicates the selected protection event occurred.
2	0x04	Error/event queue message available. Set when any error/event is entered in the System Error Queue. It is read using the SYSTem:ERRor? query.
3	0x08	Questionable Status flag. Indicates the quality of the current data being acquired. This bit is not used.
4	0x10	Message available (MAV). Indicates a message is available to read via serial or Ethernet.
5	0x20	Standard Event Status Register (ESR). Summary bit for the ESR. Set when any of the ESR bits are set and cleared when the ESR is read.
6	0x40	Request Service flag (RQS) for serial polling or Master Summary Status (MSS) in response to *STB? If service requests are enabled (with the *SRE command), this bit represents the RQS and will be sent in response to a serial poll, then cleared. If RQS is not enabled, the bit represents the MSS bit and indicates the device has at least one reason to request service. Even though the device sends the MSS bit in response to a status query (*STB?), it is not sent in response to a serial poll. It is not considered part of the IEEE-488.1 Status Byte.
7	0x80	Operation Status flag. Indicates the current operational state of the unit. This bit is not used.

6.2.2 Standard Event Status Register (ESR)

Read the Standard Event Status Register (ESR) by issuing the *ESR? command. Reading this register or issuing a *CLS command will clear the ESR. Use the *ESE (Standard Event Status Enable Register) to enable corresponding ESR bits to be summarized in the summary bit of the SCPI Status byte. To configure the Digital Interface Adapter (DIA) to generate service requests based on the ESR, both the Standard Event Status Enable Register and the Service Request Enable Register must be programmed. See , and refer to Section 5 for further information.

Table 6-2. Standard Event Status Register

Bit	Hex Value	Description
0	0x01	Operation Complete
1	0x02	Request Control - not used
2	0x04	Query Error
3	0x08	Device Dependent Error
4	0x10	Execution Error (e.g., range error)
5	0x20	Command Error (e.g., syntax error)
6	0x40	User Request - not used
7	0x80	Power On

6.2.3 Protection Condition and Protection Event Status Register

These two registers have the same bit meanings, but they differ in function.

Read the **Protection Condition Register** by issuing the STAT:PROT:COND? command. This command gives the *present* status *condition* of the power hardware, so the data is not latched. It is meant to be used as a polling register.

Read the **Protection Event Status Register** by issuing the STATus:PROTEction:EVENT? command. Reading this register clears the Protection Event Status Register. Or clear the Protection Event Status Register by issuing a *CLS command or a *RST command. Bits in the Protection Event Status Register will be set only when the corresponding bit in the Protection Event Status Enable Register is set and the corresponding event occurs. The status is then latched and will remain in that state until it is read or cleared due to some command action. (Set the Enable Register with the STATus:PROTEction:ENABLE <mask> command, and query the Enable Register with the STATus:PROTEction:ENABLE? query).

To configure the Digital Interface Adapter (DIA) to generate service

requests based on the Protection Event Status Register, program both the Protection Event Status Enable Register and the Service Request Enable Register (*SRE). For further information, refer to the table below, and to **SCPI Status Implementation** page 8-1.

Table 6-3. Protection Condition and Event Status Registers

Bit	Hex Value	Description
0	0x01	Constant voltage operation
1	0x02	Constant current operation
2	0x04	Not used
3	0x08	Overvoltage protection tripped
4	0x10	Overtemperature protection tripped
5	0x20	Supply external shutdown active
6	0x40	Foldback mode operation
7	0x80	Remote programming error

6.2.4 Operation Status and Questionable Status Registers

The Operation Status and Questionable Status Registers will always return 0 when queried. The Operation Status Enable and Questionable Status Enable Registers can be programmed and queried to allow SCPI compatibility but have no effect on the Operation Status and Questionable Status Registers.

6.2.5 Error/Event Queue

The Digital Interface Adapter (DIA) maintains an Error/Event Queue as defined by SCPI. The queue holds up to 10 error events. It is queried using the SYSTem:ERRor? command which reads in a First In/First Out (FIFO) manner. The read operation removes the entry from the queue. The *CLS command will clear all entries from the queue.

The following error codes are defined in the SCPI 1995.0 specification and are supported by the DIA. Error codes are in the range of [-32768, 32767]. SCPI reserves the negative error codes and 0, while error codes greater than 0 are device specific errors.

Table 6-4. SCPI Error Codes

Error Code	Description
206	No channels setup to trigger This means that an attempt was made to trigger the DIA using the TRIG:TYPE <1 2 3> command when there are no armed trigger settings. This error is <i>not</i> generated when the GET is received, even when there are no armed trigger settings.
205	GPIB GET not allowed during message This error means that the GPIB G(roup) E(xecute) T(ripper) multiline command was errantly generated by the system computer while or very shortly after a message is or was sent. Give a few milliseconds after a message was sent before attempting a GET; and never send a GET during the midst of a message transfer over the GPIB.
204	GPIB IFC caused warm boot This error relates to the GPIB IFC signal, and is available only in association with a proprietary command.
203	Hardware watchdog warm boot This error is caused by a hardware fault either in the power supply proper, or on the DIA. One possible explanation might be that the mains power to the supply was interrupted for a short but sufficient time to cause the DIA processor to reset and re-boot. Also, it might be possible to generate this error by a very momentary off action of the front panel power switch.
202	Foreground watchdog warm boot This error means that the internal firmware on the DIA found an internal error condition that halted processing; to force resumption of processing, a warm boot was required.

Error Code	Description
201	Unexpected warm boot This error means that the DIA processor experienced a warm boot that was unexpected, and it may indicate an internal crash of the DIA processor.
102	Incompatible unit type This error is not used. It cannot occur.
100	Incompatibility error This error is not used. It cannot occur.
0	No error The error queue is empty.
-102	Syntax error An unrecognized command or data type was encountered.
-108	Parameter not allowed More arguments than expected were received.
-151	Invalid string data Incorrect password. Manufacturer, model, or serial number string was more than 16 characters. Invalid mnemonic.
-161	Invalid block data The expected number of data values was not received.
-200	Execution error An error/event number in the range [-299,-200] indicates that an error has been detected by the instruments execution control block. The occurrence of any error in this class shall cause the execution error bit (bit 4) in the Event Status Register to be set. An execution error can be the result of: <ul style="list-style-type: none"> • A <program data> element out of range, such as programming 35 volts in a 33 volt device. • A command could not be executed due to the current condition of the device.
-203	Command protected Attempted to store calibration values to EEPROM without unlocking.
-221	Settings conflict Attempted to set output greater than soft limits or to set soft limits less than output.
-222	Data out of range Parameter exceeded range of valid values.
-225	Out of memory There is not enough memory to perform the requested operation.
-241	Hardware missing A legal command or query could not be executed because of a hardware fault.
-284	Program currently running A legal command or query could not be executed because a function is currently running.
-292	Referenced name does not exist
-293	Referenced name already exists
-316	Checksum error

Error Code	Description
-330	Self-test failed A self-test failure has occurred.
-340	Calibration failed Error during calculation of calibration values occurred.
-350	Queue overflow The error queue can contain up to 10 entries. If more than 10 error/event conditions are logged before the SYSTem:ERRor? query, an overflow will occur; the last queue entry will be overwritten with error -350. When the queue overflows, the least recent error/events remain in the queue and the most recent error/events are discarded.
-360	Communication error Communications to a channel was disrupted.

6.2.6 Serial Poll Operation

Performing a serial poll will not modify the Status Byte other than to clear the RQS (bit 6) for a Digital Interface Adapter (DIA) requesting service. Queries affecting the Status Registers and subsequent serial poll are described below:

- *STB? clears the Status Byte
- *ESR? clears the ESR and bit 5 of the Status Register
- SYSTem:ERRor? clears bit 2 of the Status Register if the queue is empty

6.3 ETHERNET LXI™, VXI-11, AND SCPI CONFORMANCE INFORMATION

The Digital Interface Adapter (DIA) for the Ethernet is IEEE-802.3 and LXI™ class C compliant. The syntax of all SCPI commands implemented by the SG power supplies and documented in this manual, are either SCPI confirmed in the SCPI 1995 Specification, Volume 2: Command Reference, or they are customized commands not part of the SCPI definition. None of the commands implemented by the SG power supplies are classified as SCPI approved commands (approved by the SCPI Consortium but not contained in the SCPI version to which the SG power supplies conform).

To document whether the syntax of each command is SCPI compliant or not, this manual provides a column, labeled “SCPI”, in each command reference table. A “C” in the “SCPI” column means that the command syntax is SCPI compliant; an “N” in the “SCPI” column means that the command syntax is not part of the SCPI definition.

6.3.1 Parameter Definitions

The following table describes the format of the command arguments, when applicable.

PARAMETER DEFINITIONS	
Type	Valid Arguments
<boolean>	“ON” or 1. “OFF” or 0.
<NR1>	The data format <NR1> is defined in IEEE 488.2 for integers. Zero, positive and negative integer numeric values are valid data.
<NRf>	The data format <NRf> is defined in IEEE 488.2 for flexible Numeric Representation. Zero, positive and negative floating point numeric values are some examples of valid data.
<string>	Characters enclosed by single or double quotes.

6.3.2 Units

The SGA/SGI power supplies will accept the following units as suffixes to numeric values:

UNITS	
Type of Unit	Valid Suffix
Voltage	"VOLTS" or "volts", "V" or "v", "MV" or "mv" or "mV"
Current	"AMPS" or "amps", "A" or "a", "MA" or "ma" or "mA"
Time	"SEC" or "sec", "S" or "s", "MS" or "ms", "MIN" or "min"
Frequency	"HZ" or "hz"

The default units are VOLTS, AMPS, SEC, and HZ.
 For example, "SOUR:VOLT 1" programs 1 volt.
 To program in units of millivolts, type "SOUR:VOLT 1mV".

6.3.3 Conventions

SCPI uses the conventions where optional commands and parameters are enclosed by "[]". Additionally the shorthand version of a command is indicated by capital letters.

For example,

```
SOURce:VOLTage[:LEVel][:IMMediate][:AMPLitude] 120.0
```

can be written as

```
SOURce:VOLTage 120.0
```

or

```
SOUR:VOLT 120.0
```

6.3.4 Queries

The query syntax is identical to the command syntax with a "?" appended. For example, to query the programmed voltage, send the string: SOURce:VOLTage?. A subsequent device read will return a value such as "33.000". All queries are terminated with a carriage return and line feed (0x0D 0x0A). When the power supply has nothing to report, its output buffer will contain two ASCII characters: a carriage return and linefeed (in decimal the values are: <13><10>).

6.4 IEEE 488.2 COMMON COMMAND SUBSYSTEM

The following commands are common to all SCPI instruments and declared mandatory by IEEE 488.2. In the following table, the Digital Interface Adapter (DIA) is defined as the “device” on the GPIB bus.

Command	Description
*CLS	Clears all status reporting data structures including the Status Byte, Standard Event Status Register, and Error Queue. The STAT:PROT:ENAB (protection event enable register) is cleared by this command; other enable registers are not cleared by this command.
*ESE <0+NR1>	Sets the value of the Standard Event Status Enable Register that determines which bits can be set in the Standard Event Status Register. See section 6.2.2 for valid values.
*ESE?	Returns the integer value of the Standard Event Status Enable Register. See section 6.2.2 for valid values. Response: <0+NR1>
*ESR?	Returns the integer value of the Standard Event Status Register. The ESR and the Status Byte ESR bit are cleared. See section 6.2.2 for valid values. Response: <0+NR1>
*IDN?	Returns the device identification as an ASCII string. Response: <Manufacturer>, <model>, <serial number>, <DCI firmware version> <AI firmware version> Example: Sorensen, SGA100/150C-1AAA, 0622A00111, 1.00,1.00
*OPC	Enables the Operation Complete bit of the Standard Event Status Register to be set when all pending operations are complete. See section 6.2.2.
C*OPC?	Returns the integer value “1” when all pending operations are complete. See section 6.2.2. Response: <0+NR1>
*RCL <integer>	SGI ONLY - Specifies the preset storage location (0 through 9) from which to load into the supply's Voltage, Current, Overvoltage Protection, and Output State settings. Preset location 0 stores the supply's power on default.
*RST	Resets the supply to its Power ON (PON) state. Clears all status reporting data structures including the Status Byte, Standard Event Status Register, and Error Queue. The STAT:PROT:ENAB (protection event enable register) is cleared by this command; other enable registers are not cleared by this command.
*SAV <integer>	Specifies the preset storage location (0 through 9) to store the supply's existing Voltage, Current, Overvoltage Protection, and Output State settings. Preset location 0 stores the supply's power up default.

Command	Description
*SRE <0+NR1>	Sets the value of the Service Request Enable Register, which determines which bits in the Status Byte will cause a service request from the device. See section on Status Byte for valid values.
*SRE?	Returns the integer value of the Service Request Enable Register. See section on Status Byte for valid values. Values range from 0-63 or 128-191. Response: <0+NR1>
*STB?	Returns the integer value of the Status Byte with bit 6 representing the Master Summary Status (MSS) instead of RQS. The MSS bit acts as a summary bit for the Status Byte and indicates whether the device has at least one reason to request service based on the MAV and the ESR bits. The Status Byte is cleared. See section on Status Byte for valid values. Values range from 0-255. Response: <0+NR1>
*TST?	Sets the device to execute an internal self-test and return the integer value of the results. Value of "0" indicates no errors. Response: <0+NR1>
*WAI	Sets the device to wait until all previous commands and queries are complete before executing commands following the *WAI command.

6.5 SOURCE SCPI COMMAND SUBSYSTEM

This section first presents a tree summary of the SOURce commands and then provides a tabular description.

6.5.1 SOURCE SCPI Command Summary

SOURce

```

:CURRent
:CURRent?
  [:LEVel]
  [:LEVel?]
    [:IMMediate]
    [:IMMediate?]
      [:AMPLitude] <NRf>
      [:AMPLitude?]
:LIMit
:LIMit?
  [:AMPLitude] <NRf>
  [:AMPLitude?]
:RAMP <NRf> <NRf>
:RAMP?
  :ABORt
  :ALL?
  :HTRIGgered <NRf>
  :HTRIGgered?
  :TRIGgered <NRf> <NRf>
  :TRIGgered?
:TRIGgered
:TRIGgered?
  :CLEar
  :AMPLitude <NRf>
  :AMPLitude?
:POWer (Available only with SGI power supplies – see Section 6.13.)
:POWer? (Available only with SGI power supplies – see Section 6.13.)
  :LEVel
  :LEVel?
    :IMMediate
    :IMMediate?
      :AMPLitude <NRf>
      :AMPLitude?
:TIMEout?
:VOLTagE
:VOLTagE?
  [:LEVel]
  [:LEVel?]
    [:IMMediate]
    [:IMMediate?]
      [:AMPLitude] <NRf>
      [:AMPLitude?]
:LIMit
:LIMit?
  [:AMPLitude] <NRf>
  [:AMPLitude?]
:PROTection

```

```

:PROTection?
  [:LEVel] <NRf>
  [:LEVel?]
:TRIPped?
:STATe?
:CLEar
:RAMP <NRf> <NRf>
:RAMP?
  :ABORt
  :ALL?
  :HTRIGgered <NRf> <NRf>
  :HTRIGgered?
  :TRIGgered <NRf> <NRf>
  :TRIGgered?
:TRIGgered
:TRIGgered?
  :CLEar
  :AMPLitude <NRf>
  :AMPLitude?

```

6.5.2 SOURCE SCPI Command Reference

The letter “C” in the “SCPI” column means that the command syntax is SCPI compliant; an “N” in the “SCPI” column means that the command syntax is not part of the SCPI definition.

Command	Description	SCPI
SOURce	Source subsystem.	C
:CURRent	Sets the output current in amps (default) or in milliamps.	C
:CURRent?	Returns the output current in amps or in milliamps	C
[:LEVel]	Sets the output current in amps (default) or in milliamps.	C
[:LEVel?]	Returns the output current in amps or in milliamps.	C
[:IMMediate]	Sets the output current in amps (default) or in milliamps.	C
[:IMMediate?]	Returns the output current in amps or in milliamps	C
[:AMPLitude]	Sets the output current in amps (default) or in milliamps.	C
<NRf>		
[:AMPLitude?]	Returns the output current in amps or in milliamps	C
:LIMit	Sets an upper soft limit on the programmed output current for the supply. The soft limit prevents the supply from being inadvertently programmed above the soft limit, thus providing a method for protecting the load against damaging currents.	C
:LIMit?	Returns the upper soft limit on the programmed output current for the supply.	C
[:AMPLitude]	Sets an upper soft limit on the programmed output current for the supply.	C
<NRf>		
[:AMPLitude?]	Returns the upper soft limit on the programmed output current for the supply.	C
:RAMP <NRf> <NRf>	Sets the output current to ramp from the present value to the specified value (first argument) in the specified time (second argument). See Ramp Function description below.	N
:RAMP?	Returns 1 if the ramp is in progress, and 0 if the ramp is completed.	N
:ABORt	Aborts ramping and clears trigger mode.	N

Command	Description	SCPI
:ALL?	Returns the ramping status of all channels.	N
:HTRIGgered <NRf>	Sets the value of the output current to ramp to be implemented when the hardware trigger is received.	N
:HTRIGgered?	Returns the value of the output current to ramp to be implemented when the hardware trigger is received.	N
:TRIGgered <NRf> <NRf>	Sets the output current to ramp from the present value to the specified value (first argument) in the specified time (second argument) upon the trigger command. See Ramp description below.	C
:TRIGgered?	Returns the value that the output current is to ramp to (first value) and the time that it is to ramp (second value) upon the trigger command.	C
:TRIGgered	Sets the output voltage to the values stored by the SOURce: CURRent:TRIGger:AMPLitude command.	C
:TRIGgered?	Returns the current level that will be set upon receipt of the trigger.	C
:CLEar	Clears the value stored by the SOURce:CURRent:TRIGger:AMPLitudecommand.	C
:AMPLitude <NRf>	Stores the value of the output current to be set when the SOURce: CURRent:TRIGGered command is sent.	C
:AMPLitude?	Returns the stored value of the output current to be set when the SOURce: CURRent:TRIGGered command is sent.	C
:POWER (in SGI only)	See Section 6.13.2.	
:POWER? (in SGI only)		
:TIMEout?	Returns the integer value 1 (timeout since last query) or 0 (no timeout) of the timeout status of the channel.	N
:VOLTage	Sets the output voltage of the supply in volts (default) or in millivolts.	C
:VOLTage?	Returns the output voltage of the supply in volts or in millivolts.	C
[:LEVel]	Sets the output voltage of the supply in volts (default) or in millivolts.	C
[:LEVel?]	Returns the output voltage of the supply in volts or in millivolts.	C
[:IMMediate]	Sets the output voltage of the supply in volts (default) or in millivolts.	C
[:IMMediate?]	Returns the output voltage of the supply in volts or in millivolts.	C
[:AMPLitude] <NRf>	Sets the output voltage of the supply in amps (default) or in milliamps.	C
[:AMPLitude?]	Returns the output voltage of the supply in amps or in milliamps.	C
:LIMit	Sets the upper soft limit on the programmed output voltage. The soft limit prevents the supply from being inadvertently programmed above the soft limit, thus providing a method for protecting the load against damaging voltages.	C
:LIMit?	Returns the upper soft limit set on the programmed output voltage.	C
[:AMPLitude] <NRf>	Sets the upper soft limit on the programmed output voltage.	C
[:AMPLitude?]	Returns the upper soft limit on the programmed output voltage.	C
:PROTection	Sets the overvoltage protection trip point in volts (default) or	C

Command	Description	SCPI
	in millivolts.	
:PROTection?	Returns the set overvoltage protection trip point in volts (default) or in millivolts.	C
[:LEVel] <NRf>	Sets the overvoltage protection trip point in volts (default) or in millivolts.	C
[:LEVel?]	Returns the set overvoltage protection trip point in volts or in millivolts.	C
:TRIPped?	Returns 1 (TRIPPED) or 0 (UNTRIPPED) state of the overvoltage protection CIRCUIT.	C
:STATe?	Returns the state 1 (ON) or 0 (OFF) If the overvoltage protection is enabled.	C
:CLEAr	Clears the overvoltage protection CIRCUIT.	C
:RAMP <NRf> <NRf>	Sets the output voltage to ramp from the present value to the specified value (first argument) in the specified time (second argument). See Ramp Function description Section 6.5.3.	N
:RAMP?	Returns 1 if the ramp is in progress, and 0 if the ramp is completed.	N
:ABORT	Aborts ramping and clears trigger mode.	N
:ALL?	Returns the ramping status of all channels.	N
:HTRIGgered <NRf>	Sets the value of the output voltage ramp to be implemented when the hardware trigger is received.	N
:HTRIGgered?	Returns the value of the output voltage ramp to be implemented when the hardware trigger is received.	N

Command	Description	SCPI
<NRf> :TRIGgered <NRf>	Sets the output voltage to ramp from the present value to the specified value (first argument) in the specified time (second argument) upon the trigger command. See description of the Ramp Function below.	N
:TRIGgered?	Returns the output voltage to ramp	N
:TRIGgered	Sets the output voltage to the values stored by the SOURce:VOLTage:TRIGger:AMPLitude command.	C
:TRIGgered?	Returns the voltage level that will be set upon receipt of the trigger.	C
:CLEar	Clears the value stored by the SOURce:VOLTage:TRIGger:AMPLitude command.	C
:AMPLitude <NRf>	Stores the value of the output current to be set when the SOURce:VOLTage:TRIGgered command is sent.	C
:AMPLitude?	Returns the stored value of the output current to be set when the SOURce:VOLTage:TRIGgered command is sent.	C

6.5.3 RAMP FUNCTION

The ramp function allows the user to transition from one voltage or current to another linearly in a specified time period (100 ms - 99 sec with 100 ms programming resolution). A unit may ramp only voltage or current, not both at a given time.

For example, SOUR:VOLT:RAMP:TRIG 1 1 followed by SOUR:CURR:RAMP:TRIG 2 2 will cause the unit to ramp only the output current to 2 amps in 2 seconds upon the TRIG:RAMP command.

VOLTAGE RAMPING TO A HIGHER VOLTAGE

Requires a programmed current of at least 20% of the full scale value. Settings less than 20% will significantly lengthen the ramp time due to charging of the large capacitance in the output section of the power supply.

VOLTAGE RAMPING TO A LOWER VOLTAGE

Requires an appropriate resistive load. The discharge rate of the large capacitance in the output section of the power supply, plus other user capacitance, significantly lengthens the ramp time.

CURRENT RAMPING

Requires an appropriate resistive load.

6.6 MEASURE SCPI COMMAND SUBSYSTEM

This section first presents a tree summary of the MEASure commands and then provides a tabular description.

6.6.1 MEASURE SCPI Command Summary

MEASure

```

:CURRent
:CURRent?
    :AVERage <value>
    :AVERage?
:POWer? (Available only with SGI power supplies – see Section 6.13.)
:VOLTagE
:VOLTagE?
    :AVERage <value>
    :AVERage?

```

6.6.2 MEASURE SCPI Command Reference

The letter “C” in the “SCPI” column means that the command syntax is SCPI compliant; an “N” in the “SCPI” column means that the command syntax is not part of the SCPI definition.

Command	Description	SCPI
MEASure	Measure subsystem.	C
:CURRent?	Returns the floating point value of the DC output current in amps.	C
:CURRent	Measure Current subsystem.	N
:AVERage <NR1>	Enter a value of 1 to 5 to set the number of readings to average together when returning the current value from the MEAS:CURR? command. This function reduces noise in the readback readings. The (default) value of 1 provides the fastest response time, but the noisiest readings.	N
:AVERage?	Returns the number 1 to 5 to indicate the last set number of readings to average together when taking a current reading.	N
:POWer? (SGI only)	see Section 6.13	
:VOLTagE?	Returns the floating point value of the DC output voltage in volts.	C
:VOLTagE	Measure Voltage subsystem.	N
:AVERage <NR1>	Enter a value of 1 to 5 to set the number of readings to average together when returning the voltage value from the MEAS:VOLT? command. This function reduces noise in the readback readings. The (default) value of 1 provides the fastest response time, but the noisiest readings.	N
:AVERage?	Returns the number 1 to 5 to indicate the last set number of readings to average together when taking a voltage reading.	N

6.7 OUTPUT SCPI COMMAND SUBSYSTEM

This section first presents a tree summary of the OUTPut commands and then provides a tabular description.

6.7.1 OUTPUT SCPI Command Summary

OUTPut

```

:ISOLation <boolean>
:ISOLation?
:POLarity <string>
:POLarity?
:PROTection
    :DElay <NRf>
    :DElay?
    :FOLD <0|1|2>
    :FOLD?
:SENSE <boolean>
:SENSE?
:STATe <boolean>
:STATe?
:TRIPped?
    
```

6.7.2 OUTPUT SCPI Command Reference

The letter “C” in the “SCPI” column means that the command syntax is SCPI compliant; an “N” in the “SCPI” column means that the command syntax is not part of the SCPI definition.

Command	Description	SCPI
OUTPut	Output subsystem.	C
:ISOLation <boolean>	Sets the rear panel isolation relay control signal ON or OFF. Valid arguments are 1/ON or 0/OFF.	N
:ISOLation?	Returns the state of the rear panel isolation relay control signal: 1 = ON 0 = OFF	N
:POLarity <NORM/0/OFF INV/1/ON>	Changes the state of the polarity relay. This command requires that the isolation relay be open beforehand. If the isolation relay is closed when this command is attempted, the state of the polarity relay will not change, and an error message will be generated.	C
:POLarity?	Returns the state of the polarity relay: <NORM/0/OFF INV/1/ON>	C
:PROTection	Output Protection subsystem.	N
:DElay <NRf>	Sets the programmable time delay executed by the supply before reporting output protection conditions after a new output voltage or current is specified. Functional granularity of +/- 0.5 seconds	N
:DElay?	Returns the time delay to be executed by the supply.	N

Command	Description	SCPI
:FOLD <0 1 2>	Sets the foldback (program down) mode of the supply. Valid arguments are 0 (OFF or do nothing, do not program down to zero), 1 (program down to zero upon entering constant-voltage mode), or 2 (program down to zero upon entering constant-current mode).	N
:FOLD?	Returns the set foldback (program down) mode of the supply. 0 = OFF; will not program down. 1 = will program down to zero upon entering constant-voltage mode. 2 = will program down to zero upon entering constant current mode	N
:SENSe <boolean>	Sets the sense relay signal open or close. Valid arguments are 1/ON or 0/OFF.	N
:SENSe?	Returns the setting of the sense relay signal: 1 = ON 0 = OFF	N
:STATe <boolean>	Sets the output to zero or the programmed value; opens or closes the isolation relay. Valid arguments are 1/ON or 0/OFF. *RST state value is ON.	C
:STATe?	Returns the state of the output: 1 = ON 0 = OFF	C
:TRIPped?	Returns the integer value 1 (TRIPPED) or 0 (UNTRIPPED) state of the output.	N

6.8 STATUS SCPI COMMAND SUBSYSTEM

This section first presents a tree summary of the STATus commands and then provides a tabular description.

Note: See Section 5 for further information.

6.8.1 STATUS SCPI Command Summary

STATus

```

:OPERation
  :CONDition?
  :ENABle <NR1>
  :ENABle?
  :EVENT?
:PRESet
:PROTection
  :CONDition?
  :ENABle <NR1>
  :ENABle?
  :EVENT?
  :SELEct <NR1>
  :SELEct?
:QUEStionable
  :CONDition?
  :ENABle <NR1>
  :ENABle?
  :EVENT?

```

6.8.2 STATUS SCPI Command Reference

The letter “C” in the “SCPI” column means that the command syntax is SCPI compliant; an “N” in the “SCPI” column means that the command syntax is not part of the SCPI definition.

Command	Description	SCPI
STATus	Status subsystem.	C
:OPERation	Status Operation subsystem.	C
:CONDition?	Returns the integer value of the Operation Condition Register. The query is supported but will always return “0” indicating operational condition.	C
:ENABle <NR1>	Sets the enable mask of the Operation Event Register allowing true conditions to be reported in the summary bit of the Operation Condition Register. Values are written and queried but have no effect on the Operation Condition Register.	C
:ENABle?	Returns the value of the current mask if the Operation Event Register.	C
:EVENT?	Returns the integer value of the Operation Event Register. This query is supported but always returns a value of “0” indicating operational condition.	C
:PRESet	Sets the enable mask of the Operation Event Register and the Questionable Event Register to all 1’s.	C
:PROTEction	Status Protection subsystem.	C
:CONDition?	Returns the integer value of the Protection Condition Register. Used to read the status of the power hardware. See section 6.2.3 for a detailed table of the various bits that make up this register.	C
:ENABle <NR1>	Sets the enable mask of the Protection Event Register, which allows true conditions to be reported in the summary bit of the Protection Condition Register.	C
:ENABle?	Returns the value of the current mask of the Protection Event Register.	C
:EVENT?	Returns the integer value of the Protection Event Register.	C
:SELEct <NR1>	This command provides a means for selecting which fault bits from the protection event register (also called the fault register and can be read using the STAT:PROT:EVEN? command) are able to set the protection event flag bit in the SCPI status byte (readable using the *STB? command). It defaults to value 255 at power-on time, and never changes unless intentionally programmed to a new value.	N
:SELEct?	Returns the last selection value programmed.	N
:QUEStionable	Status Questionable subsystem.	C
:CONDition?	Returns the integer value of the Questionable Condition Register. The query is supported but will always return “0” indicating operational condition.	C
:ENABle <NR1>	Sets the enable mask of the Questionable Event Register allowing true conditions to be reported in the summary bit of the Questionable Condition Register. Values are written and queried but have no effect on the Questionable Condition Register.	C
:ENABle?	Returns the value of the current mask of the Questionable Event Register.	C
:EVENT?	Returns the integer value of the Questionable Event Register. This query is supported but always returns a value of “0”, indicating operational condition.	C

6.9 SYSTEM SCPI COMMAND SUBSYSTEM

This section first presents a tree summary of the SYSTEM commands and then provides a tabular description.

6.9.1 SYSTEM SCPI Command Summary

SYSTEM

- :ERRor?
- :FAULt?
- :LOCAL <boolean>
- :LOCAL?
 - :LOCKOUT <boolean>
 - :LOCKout?
- :NET
 - :AUTOIP <boolean>
 - :AUTOIP?
 - :DESC <string>
 - :DESC?
 - :DHCPMODE <boolean>
 - :DHCPMODE?
 - :DNS <string>
 - :DNS?
 - :GATE <string>
 - :GATE?
 - :HOST <string>
 - :HOST?
 - :IP <string>
 - :IP?
 - :LANLED <boolean>
 - :LANLED?
 - :MAC?
 - :MASK <string>
 - :MASK?
 - :NETBUTTON <string>
 - :PINGRESP <boolean>
 - :PINGRESP?
 - :PORT <NRf>
 - :PORT?
 - :PRICONF <NR1>
 - :PRICONF?
 - :SECCONF <NR1>
 - :SECCONF?
 - :TERM <NRf>
 - :TERM?
- :VERsion?

6.9.2 SYSTEM SCPI Command Reference

The letter “C” in the “SCPI” column means that the command syntax is SCPI compliant; an “N” in the “SCPI” column means that the command syntax is not part of the SCPI definition.

Command	Description	SCPI
SYSTem	System subsystem.	
:ERRor?	Queries Error Queue for next error/event entry (first in, first out). Entries contain an error number and descriptive text. A 0 return value indicates no error occurred; negative numbers are reserved by SCPI. The maximum return string length is 255 characters. The queue holds up to 10 error/entries. All entries are cleared by the *CLS command.	C
:FAULt?	Returns four numeric values separated by commas for the four system fault registers. See System Fault Registers (Table 6-5). Valid response is 128, 0, 0, 0 or 0, 0, 0, 0. Response: <Fault1–8>, <Fault9–16>, <Fault17–24>, <Fault25–31>	N
:LOCAL <boolean>	Forces the supply to local or remote state. <ON> or <1> sets operation to local mode. <OFF> or <0> sets the operation to remote mode. There are two noteworthy circumstances where this command may prove necessary. The first case involves using RS232 to communicate with the supply, since the normal GPIB mechanisms for transition between local and remote and back again do not exist when using RS232. The other case is when the REMOTE/LOCAL switch S1-1 is placed in the ON position—thereby disabling the GPIB mechanism for transition from remote to local.	N
:LOCAL?	Returns ON or 1 if in local mode. Returns OFF or 0 if in remote mode.	N
:LOCKout <boolean>	The SYST:LOCAL:LOCKOUT <0 1 OFF ON> command provides a means of controlling the local lockout functionality that is an alternative to the low level GPIB LLO command. In contrast, using the GPIB LLO low level command causes the supply to be placed into the local lockout state. To place the supply into the local lockout state, use the SYST:LOCAL:LOCKOUT command.	N
:LOCKOUT?	Returns 0 (off) or 1 (on)	N
SYST:NET	Network device	N
:AUTOIP <boolean>	Sets the network Auto IP mode in the Primary configuration without affecting the Secondary configuration.. 0 = disable AutoIP; 1 = enable AutoIP	N
:AUTOIP?	Returns 1 if AutoIP is enabled in the Primary configuration. Returns 0 if AutoIP is disabled in the Primary configuration.	N
:DESC <string>	Set the network Description, a 36 character alphanumeric string	N
:DESC?	Returns the network Description.	N
:DHCPMODE <boolean>	Sets the network DHCP Mode in the Primary configuration without affecting the Secondary configuration. 0 = disable DHCP; 1 = enable DHCP	N

Command	Description	SCPI
:DHCPMODE?	Returns 1 if DHCP Mode is enabled in the Primary configuration. Returns 0 if DHCP mode is disabled in the Primary configuration.	N
:DNS <string>	Sets the network DNS IP address for the device. String is in the format "NNN.NNN.NNN.NNN" where "NNN" = 0 through 255, inclusive.	N
:DNS?	Returns the network DNS address for the device.	N
:GATE <string>	Sets the network gateway IP address for the device. String is in the format "NNN.NNN.NNN.NNN" where "NNN" = 0 through 255, inclusive.	N
:GATE?	Returns the network gateway IP address for the device.	N
:HOST <string>	Set the network Host Name, a 15-character (maximum) alphanumeric string. (Must be limited to 15 characters for LXI compliance)	N
:HOST?	Returns the network Host Name	N
:IP <string>	Sets the Primary configuration to STATICIP mode and sets the network IP address for the device. String is in the format "NNN.NNN.NNN.NNN" where "NNN" = 0 through 255, inclusive.	N
:IP?	Returns two IP addresses: the first is the IP address set to be used when the system boots up; the second is the IP address presently in use by the power supply. (The first address will either be 0.0.0.0. if the Primary configuration is DHCP or DHCP+AUTOIP, or it will be the static IP last specified).	N
:LANLED <boolean>	1 causes LANLED to blink. (Used to identify a unit in a rack). 0 causes LANLED to stop blinking.	N
:LANLED?	Returns blink state of the LAN LED: 0 – not blinking; 1 – blinking.	N
:MAC?	Returns the network MAC address. xx:xx:xx:xx:xx:xx (Hexadecimal digit pairs)	N
:MASK <string>	Set the network Subnet Mask for the device. String is in the format "NNN.NNN.NNN.NNN" where "NNN" = 0 through 255, inclusive.	N
:MASK?	Returns the network Subnet Mask for the device.	N
:NETBUTTON <string>	Returns configuration parameters to factory default. (Software equivalent of pressing the Reset switch on the rear panel of the power supply). You must cycle the power to effect the change. The access string is "6867."	N
:PINGRESP <boolean>	Set ping response: 1 = unit responds to ping (response enabled). 0 = ping response is not enabled.	N
:PINGRESP?	Returns 1 if ping response is enabled. Returns 0 if ping response is not enabled.	N
:PORT <Nrf>	Set the network TCP/IP socket listening port. Valid values are 1025 to 65535.	N
:PORT?	Returns the network TCP/IP socket listening port.	N
:PRICONF <NR1>	Sets Primary IP configuration. 1 = DHCP; 2 = DHCPAUTOIP; 0 = STATICIP	N
:PRICONF?	Returns currently set Primary IP configuration 1 = DHCP; 2 = DHCPAUTOIP; 0 = STATICIP	N
:SECCONF <NR1>	Sets Secondary IP configuration. 1 = DHCP; 2 = DHCPAUTOIP; 0 = STATICIP	N
:SECCONF?	Returns currently set Secondary IP configuration. 1 = DHCP; 2 = DHCPAUTOIP; 0 = STATICIP	N

Command	Description	SCPI
<NRf> :TERM	Sets the return string terminators to be used by the device. Factory set to 3. The valid range is 1-4. Values indicate the following terminator(s): 1 = 0x0d only (CR), 2 = 0x0a only (LF), 3 = 0x0d 0x0a (CR LF), 4 = 0x0a 0x0d (LF CR)	N
:TERM?	Returns the string terminators to be used by the device.	N
:VERSION?	Returns a numeric value corresponding to the SCPI version number for which the instrument complies. The response is in the format YYYY.V where the Y's represent the year and V represents the approved version number for that year (e.g., 1995.0)	C

Table 6-5. System Fault Registers

Bit Position	Bit Weight	Fault1–8	Fault9–16	Fault17–24	Fault25–31
7	128	Channel 1	not used	not used	not used
6	64	not used	not used	not used	not used
5	32	not used	not used	not used	not used
4	16	not used	not used	not used	not used
3	8	not used	not used	not used	not used
2	4	not used	not used	not used	not used
1	2	not used	not used	not used	not used
0	1	not used	not used	not used	not used

The `SYSTEM:FAULT?` query returns 4 numeric values separated by commas. Each value is the decimal equivalent of the total bit weights for that System Fault Register as described in the table above.

6.10 HTRIGGER SCPI COMMAND SUBSYSTEM

This section applies only to units with the External User Interface (Currently only available on Ethernet versions).

The HTRIGGER function allows the user to apply an External User Interface input signal to initiate a sequence or a voltage or current ramp. Once a hardware trigger is run, Arm goes to 0 (not armed); however, the last loaded sequence remains in memory.

6.10.1 HTRIGGER SCPI Command Summary

HTRIGger

:ABORt

:RAMP

:SEQuence (Available only with SGI power supplies – see Section 6.13.)

:SEQuence? (Available only with SGI power supplies – see Section 6.13.)

:ARM (Available only with SGI power supplies – see Section 6.13.)

:ARM? (Available only with SGI power supplies – see Section 6.13.)

6.10.2 HTRIGGER SCPI Command Reference

Command	Description	SCPI
HTRIGger	Hardware trigger subsystem.	N
:ABORt	Stops the execution of a currently running hardware trigger function. In addition: For Ramp: Clears all settings of voltage and current. For Sequence: Sets the Arm function to 0 (not armed).	N
:RAMP	Executes voltage or current ramping function previously programmed by the SOURce command, i.e., SOURce:VOLTagE:RAMP SOURce:CURRent:RAMP	N
:SEQuence <string> (SGI only)	Loads a Sequence to be initialized by the external Hardware Trigger. This command must be followed by the HTRIG:ARM command before the Hardware Trigger becomes operational.	N
:SEQuence? (SGI only)	Returns the currently loaded sequence name	N
:ARM <boolean> (SGI only)	Readies the last loaded sequence to run when the external Hardware Trigger signal is issued. 1 = Ready to run sequence when Hardware trigger is engaged. 0 = Not Armed, Hardware trigger is ignored NOTE: To arm a different sequence, issue the HTRIG:SEQ command first.	N
:ARM? (SGI only)	Returns the ready status of the last loaded sequence. 1 = Ready to run sequence when Hardware trigger is engaged. 0 = Not Armed, Hardware trigger is ignored NOTE: To load a new sequence to be armed you must issue the HTRIG:SEQ command first.	N

6.11 TRIGGER SCPI COMMAND SUBSYSTEM

This section describes the programming soft trigger function.

6.11.1 TRIGGER SCPI Command Summary

TRIGger

:ABORt

:RAMP

:TYPE <1|2|3>

6.11.2 TRIGGER SCPI Command Reference

The letter “C” in the “SCPI” column means that the command syntax is SCPI compliant; an “N” in the “SCPI” column means that the command syntax is not part of the SCPI definition.

Command	Description	SCPI
TRIGger	Trigger subsystem.	C
:ABORt	Stops the execution of a currently running trigger function, and clears all settings of voltage and current.	N
:RAMP	Executes voltage or current ramping function previously programmed by the SOURce command, i.e., SOURce:VOLTagE:RAMP SOURce:CURREnt:RAMP	N
:TYPE<1 2 3>	Executes voltage and current values previously programmed by the SOURce command i.e., SOURce:VOLTagE:LEVel:TRIGger SOURce:CURREnt:LEVel:TRIGger Valid arguments are 1 (Voltage), 2 (Current), or 3 (Both).	N

6.12 CALIBRATION SCPI COMMAND SUBSYSTEM

Note: See Section 7 for calibration procedures.



Please refer to the power supply manual for further information before performing calibration procedures. Calibration must be performed by qualified personnel who appropriately deal with attendant hazards. If calibration is not performed properly, functional problems could arise, requiring that the supply be returned to the factory.

6.12.1 CALIBRATION SCPI Command Summary

CALibrate

```

:DATA <NRf><NRf><NRf><NRf><NRf><NRf><NRf><NRf><NRf><NRf>
:DATE <NRf> (applies to GPIB; for Ethernet, see CAL:MOD:LASTCALDATE and CAL:MOD:NEXTCALDATE)
:DATE? (applies to GPIB; for Ethernet, see CAL:MOD:LASTCALDATE and CAL:MOD:NEXTCALDATE)
:INITial
    :CURRent <NRf>
    :CURRent?
    :VOLTagE
    :VOLTagE?
        [:AMPLitude] <NRf>
        [:AMPLitude?]
    :PROTection <NRf>
    :PROTection?

:MEASure
    :CURRent
        :ADC?
        :CALCulate
        :GAIN <NRf>
        :GAIN?
        :OFFSet <NRf>
        :OFFSet?
        :POINT <1|2> <NRf>
    :VOLTagE
        :ADC?
        :CALCulate
        :GAIN <NRf>
        :GAIN?
        :OFFSet <NRf>
        :OFFSet?
        :POINT <1|2> <NRf>

:MODEl
    :LASTCALDATE (applies to Ethernet only; for GPIB, see CAL:DATE)
    :LASTCALDATE? (applies to Ethernet only; for GPIB, see CAL:DATE?)
    :NEXTCALDATE (applies to Ethernet only)
    :NEXTCALDATE? (applies to Ethernet only)
    :POWERON
    :POWERON?
    :RESET
    :RESET?

```

```
:OUTPut
  :CURRent
    :CALCulate
    :DAC <NR1>
    :FIVEPoint <1|2|3|4|5> (applies to Ethernet only)
    :FIVEPoint? (applies to Ethernet only)
    :GAIN <NRf>
    :GAIN?
    :OFFSet <NRf>
    :OFFSet?
    :POINT <1|2> <NRf>
  :VOLTagE
    :CALCulate
    :DAC <NR1>
    :FIVEPoint <1|2|3|4|5> (applies to Ethernet only)
    :FIVEPoint? (applies to Ethernet only)
    :GAIN <NRf>
    :GAIN?
    :OFFSet <NRf>
    :OFFSet?
    :POINT <1|2> <NRf>
    :PROTection
      :CALCulate
      :DAC <NR1>
      :GAIN <NRf>
      :GAIN?
      :OFFSet <NRf>
      :OFFSet?
  :UNLock <string>
:STORe
:LOCK
```

6.12.2 CALIBRATION SCPI Command Reference

The letter “C” in the “SCPI” column means that the command syntax is SCPI compliant; an “N” in the “SCPI” column means that the command syntax is not part of the SCPI definition.

Command	Description	SCPI
CALibrate	Calibration subsystem.	C
:DATA <NRf><NRf><NRf> <NRf><NRf><NRf> <NRf><NRf><NRf> <NRf>	Sets the values of the ten floating point calibration constants: 1) output voltage DAC gain 2) output voltage DAC offset 3) output current DAC gain 4) output current DAC offset 5) output voltage protection DAC gain 6) output voltage protection DAC offset 7) voltage measurement ADC gain 8) voltage measurement ADC offset 9) current measurement ADC gain 10) current measurement ADC offset Values are separated by space or comma.	N
:DATE <NRf>	(applies to GPIB; see CAL:MOD:LASTCALDATE for Ethernet) Sets the date last calibrated. (Should be changed at each calibration). Input format: YYYYMMDD	N
:DATE?	Returns the date last calibrated.	N
:INITial	Used to store next power up values.	N
:CURRent	Sets the power-on default value of current.	N
:CURRent?	Returns the default value of power-on current.	N
:VOLTagE	Sets the power-on default voltage.	N
:VOLTagE?	Returns the default value of power-on voltage	N
[:AMPLitude] <NRf>	Sets the power-on default voltage.	N
[:AMPLitude]?	Returns the power-on default voltage.	N
:PROTection <NRf>	Sets the power-on default value of the overvoltage protection.	N
:PROTection?	Returns the default value of the power-on overvoltage protection.	N
:MEASure	Calibrate Measure subsystem	N
:CURRent	Calibrate Measure Current subsystem	N
:ADC?	Returns the integer value of the A/D for the current measurement.	N
:CALCulate	Calculates the value of the gain and offset for current measurements.	N
:GAIN <NRf>	Sets the value of the gain for current measurements.	N
:GAIN?	Returns the value of the gain for current measurements.	N
:OFFSet <NRf>	Sets the value of the offset for current measurements.	N
:OFFSet?	Returns the value of the offset for current measurements.	N
:POINT <1 2> <NRf>	Sets the current measurement calibration point (1 or 2). The actual output current is measured with an external meter.	N
:VOLTagE	Calibrate Measure Voltage subsystem	N
:ADC?	Returns the integer value of the A/D for the voltage measurement.	N

Command	Description	SCPI
:CALCulate	Calculates the value of the gain and offset for voltage measurements.	N
:GAIN <Nrf>	Sets the value of the gain for voltage measurements.	N
:GAIN?	Returns the value of the gain for voltage measurements.	N
:OFFSet <Nrf>	Sets the value of the offset for voltage measurements.	N
:OFFSet?	Returns the value of the offset for the voltage measurements.	N
:POINT <1 2> <Nrf>	Sets the voltage measurement calibration point (1 or 2). The actual output voltage is measured with an external meter.	N
:MODEl	Calibrate Model subsystem	N
:LASTCALDATE<Nrf>	(Ethernet only) Sets the date last calibrated; format: MM DD YYYY (space after MM and DD required)	N
:LASTCALDATE?	(Ethernet only) Returns the date last calibrated.	N
:NEXTCALDATE<Nrf>	(Ethernet only) Sets the date next calibration is required; format: MM DD YYYY (space after MM and DD required)	N
:NEXTCALDATE?	(Ethernet only) Returns the date next calibration is required.	N
:POWERON <String>	Sets the default output enable condition at power on. Input format: "ON:INIT" enables the output at next power on "OFF:INIT" disables the output at next power on NOTE: Quotations are required in the command string.	N
:POWERON?	Returns the status of the output enable condition at power on	N
:RESET <String>	Sets the default output enable condition when the *RST command is issued. Input format: "ON:INIT" enables the default output "OFF:INIT" disables the default output NOTE: Quotations are required in the command string.	N
:RESET?	Returns the status of the default output enable condition when the *RST command is issued	N
:OUTPut	Calibrate Output subsystem	N
:CURRent	Calibrate Output Current subsystem	N
:CALCulate	Calculates the value of the gain and offset for output current.	N
:DAC <NR1>	Sets the output of the output current D/A converter.	N
:FIVEPOINT <1 2 3 4 5>	(Ethernet only) Sets output current value for each calibration point (1-5)	N
:FIVEPOINT?	(Ethernet only) Returns the entered values for 5-point calibration.	N
:GAIN <Nrf>	Sets the value of the gain for the output current.	N
:GAIN?	Returns the value of the gain for the output current.	N
:OFFSet <Nrf>	Sets the value of the offset for the output current.	N
:OFFSet?	Returns the value of the offset for the output current.	N
:POINT <1 2> <Nrf>	Sets the current output calibration point (1 or 2). The actual output current is measured with an external meter.	N

Command	Description	SCPI
:VOLTage	Calibrate Output Voltage subsystem	N
:CALCulate	Calculates the value of the gain and offset for output voltage.	N
:DAC <NR1>	Sets the output of the output voltage D/A converter.	N
:FIVEPOINT <1 2 3 4 5>	(Ethernet only) Sets output voltage value for each calibration point (1-5)	N
:FIVEPOINT?	(Ethernet only) Returns the entered values for 5-point calibration.	N
:GAIN <NRf>	Sets the value of the gain for the output voltage.	N
:GAIN?	Returns the value of the gain for the output voltage.	N
:OFFSet <NRf>	Sets the value of the offset for the output voltage.	N
:OFFSet?	Returns the value of the offset for the output voltage.	N
:POINT <1 2> <NRf>	Sets the voltage output calibration point (1 or 2). The actual output voltage is measured with an external meter.	N
:PROTection	Calibrate Output Voltage Protection subsystem	N
:CALCulate	Calculates the value of the gain and offset for output overvoltage protection. This takes more than 30 seconds to complete. Use *ESE 1 and a serial poll to detect the completed operation.	N
:DAC <NR1>	Sets the output of the output overvoltage protection D/A converter.	N
:GAIN <NRf>	Sets the value of the gain for the output overvoltage protection.	N
:GAIN?	Returns the value of the gain for the output overvoltage protection.	N
:OFFSet <NRf>	Sets the value of the offset for the output overvoltage protection.	N
:OFFSet?	Returns the value of the offset for the output overvoltage protection.	N
:UNLock <string>	Sets the non-volatile memory available to store calibration constants. The access string is "6867".	
:STORe	Stores the calibration constants in non-volatile memory.	N
:LOCK	Disables access to the non-volatile memory. Prevents attempts to store calibration values. (Issue after CAL:UNLock and CAL:STORe commands)	N

6.13 SGI-UNIQUE COMMANDS

This section deals with the SGI power supply’s unique operation commands. These commands are for programming sequences and power mode operations, which do not function with SGA power supplies.

6.13.1 Restrictions on Sequence Programming:

Do NOT use non-sequence-related commands while performing sequences.

Do NOT use sequence commands as stand-alone commands outside a sequence.

In order to allow maximum flexibility for generating small incremental changes during a test sequence, the SGI allows 1ms time resolution on each step. With this capability, however, it is possible to create output changes that generate large, and potentially damaging, currents in the output capacitors of the unit.

 CAUTION	<p><i>When creating test sequences, please use the following guidelines to prevent damage to the unit (see Note below):</i></p>
---	---

- *Estimate the AC frequency and peak-to-peak voltage (Vp-p) of the desired test sequence.*
- *Convert the estimated Vp-p to a % of maximum output voltage (e.g. if Vp-p is 10V and maximum voltage of the supply is 100V, then %Vp-p – 10%)*
- *Verify that the frequency and %Vp-p does not exceed the values below:*

Frequency	% Vp-p
10Hz	25%
50Hz	5.0%
100Hz	2.5%
150Hz	1.67%
200Hz	1.25%

Another consideration is the actual rise and fall capabilities of the output of the supply. Although damage will not occur, the shape of the output waveform will be affected by these differences. These vary widely, depending on the load conditions; contact the factory for further information.

NOTE: *Contact the factory for detailed information if the desired waveform exceeds the recommended limits as discussed.*

6.13.2 SGI SOURCE SCPI Command Subsystem

The Power command and its corresponding query were added to the Source subsystem only in SGI for power regulation (Section 6.5 contains the Source commands that can be used in both SGA and SGI). The letter “C” in the “SCPI” column means that the command syntax is SCPI compliant; an “N” in the “SCPI” column means that the command syntax is not part of the SCPI definition.

NOTE: Must be preceded by commands to set maximum voltage, overvoltage protection and current (see Description in table below).

SOUR:POWer
:POWer?

Command	Description	SCPI
SOURce :POWer <NRf>	<p>Enter a value for power regulation. This command must be used in the following manner to avoid excess power to the load:</p> <ol style="list-style-type: none"> 1) Set the output state to off using OUTP:STAT OFF 2) Program a desired voltage maximum by programming SOUR:VOLT <voltmax> 3) Program a desired OVP maximum by programming SOUR:VOLT:PROT <ovpmax> 4) Program a desired current maximum by programming SOUR:CURR <currmax> 5) Then issue the power command for the desired number of watts SOUR:POW <watts> 6) Engage the output using OUTP:STAT ON <p>After the above actions the supply should be on and regulating at the desired power level or below. (Lower level is possible because the load may draw less than the given power setting if the voltage or current maximums programmed in the preceding steps cause such limitation). Subsequently the SOUR:POW <watts> command may be issued to adjust the power level up or down.</p> <p> <i>Power mode is easily exited unintentionally by re-programming a voltage or current value, or issuing certain other commands that have a material influence over the power control loop. This possibility would cause power regulation to cease and then expose the load to either the voltage maximum or the current maximum or both; THIS COULD CAUSE EXCESS POWER BEING DELIVERED TO THE LOAD.</i> Consequently, when using power regulation, the best practice is to restrict SCPI command traffic to queries until such a time power mode is to be exited altogether. The suggestion for exiting power mode intentionally is to program the output voltage and output current to zero using SOUR:VOLT 0.0 and SOUR:CURR 0.0 See the PROG:EXEC POWERSETTINGS <watts> <vlimit> <ilimit> <ovp> command for an alternate method for entering all the relevant settings on a single command line.</p>	<p>C</p>
:POWer?	<p>After a SOUR:POWer programming command has been issued, this query command returns all of the settings inherent in that command. The return takes the following format:</p> <p><watts>w @<vlimit>v max, <ilimit>a max, <ovp>v ovp</p>	<p>C</p>

6.13.3 SGI PROGRAM SCPI Command Subsystem

The PROGRAM subsystem, only available in SGI, provides a means to program sequences. Through *sequences* power supply output settings and duration for each of those individual settings, called sequence steps, can be programmed. A sequence step includes a voltage value *with* a current value *with* an over-voltage-protection value *with* a duration value. A single sequence is a program of up to 20 steps (21 steps if the RETURN or STOP or GOTO is counted), where one step consists of a setting for the power supply output. There may be up to 50 different named sequences (programs) with up to 20 steps in each. (The default name for a program is TEST[n], where [n] is a number 01 thru 50, but may be reprogrammed with a unique name up to 15 characters.)

NOTE: Do NOT use non-sequence-related commands while performing sequences. Also do NOT use sequence commands as stand-alone commands outside a sequence.

PROGRAM SCPI COMMAND SUMMARY

PROGram

```

:INITializing?
:CATalog?
:[SElected]
  :ARM
  :ARM?
  :DEFine <step#>,VIMODE,<volts>,<amps>,<ovp>,<sec>
  :DEFine
<step#>,RAMPTOV,<volts>,<volts>,<amps>,<ovp>,<sec>
  :DEFine
<step#>,RAMPTOC,<volts>,<amps>,<amps>,<ovp>,<sec>
  :DEFine <step#>,POWERSETTINGS,<watts>,<volts>,<amps>,<ovp>,<sec>
  :DEFine <step#>,REPEAT
  :DEFine <step#>,SUBCALL, "SEQNAME"
  :DEFine <step#>,RETURN
  :DEFine <step#>,LOOP,<count>
  :DEFine <step#>,NEXT
  :DEFine <step#>,STOP
  :DEFine <step#>,GOTO, "SEQNAME"
  :DEFine <step#>,PAUSE
  :DEFine <step#>,NOP
  :DEFine? <step#>
  :DElete
    :SElected
    :ALL
  :EXECute <value1>,<value2>,<value3>,...,<valueN>
  :EXECute VIMODE <NRf> <NRf> <NRf>
  :EXECute RAMPTOV <NRf> <NRf> <NRf> <NRf> <NRf>
  :EXECute RAMPTOC <NRf> <NRf> <NRf> <NRf> <NRf>
  :EXECute POWERSETTINGS <NRf> <NRf> <NRf> <NRf>
  :MALLocate DEFAULT
  :NAME "name"
  :NAME "name",<chan#>
  :NAME?

```

```

:SAVE
    :SElected
    :ALL
:STATe <value>
:STATe?

```

PROGRAM SCPI COMMAND REFERENCE

The letter “C” in the “SCPI” column means that the command syntax is SCPI compliant; an “N” in the “SCPI” column means that the command syntax is not part of the SCPI definition.

Following this command reference table, are some annotated examples showing how to create a sequence (program) in your power supply.

Command	Description	SCPI
PROGram	Program subsystem	C
:INITializing?	This query returns 1 after mains power-on, and continues to return 1 until the program/sequence functionality is fully initialized, after which point 0 is returned. <i>Do not attempt to use any of the other sequence related commands--i.e., commands in the SCPI PROG command tree --while program/sequence functionality is initializing. (Typical initialization time is approx. 15 seconds after power-on.)</i>	N
:CATalog?	Lists all the defined sequence names. The format for the response to the query is a list of comma-separated test names.	C
: [SElected]	Selected section of program subsystem	C
:ARM	Prepares the presently selected sequence for execution; this command may take a few seconds depending the length of the selected sequence and all subsequences that the selected sequence may depend upon. The command to use to execute an armed sequence is PROG:STAT RUN.	N
:ARM?	A return of 1 means the sequence is armed. A return of 0 means it is not.	N
:DEFine <step#>, VIMODE, <volts>, <amps>, <ovp>, <s>	Programs the VIMODE sequence command into the selected sequence (see PROG:SEL:NAME command) at <step#>. The following values set by this command: voltage <volts>, current <amps>, over voltage protection <ovp>, and a duration of <s> seconds. <s> may have a decimal value with a granularity of 0.001 seconds. This command is valid for steps 1 thru 20.	C
:DEFine <step#>, RAMPTOV, <start volts>, <end volts>, <amps>, <ovp>, <s>	Programs the RAMPTOV sequence command into the selected sequence at <step#>. The following values are programmed: starting and ending voltage ramp values <start volts> and <end volts>, current <amps>, over voltage protection value <ovp>, and voltage ramping duration in <s> seconds. <s> may have a decimal value with a granularity of 0.001 seconds. This command is valid for steps 1 thru 20.	C

Command	Description	SCPI
<pre>:DEFine <step#>, RAMPTOC, <volts>, <start amps>,<end amps>, <ovp>, <s></pre>	<p>Programs the RAMPTOC sequence command into the selected sequence at <step#>. The following values are programmed: the starting and ending current ramp values <start amps> and <end amps>, voltage <volts>, over voltage protection <ovp>,and current ramping duration in <s> seconds. <s> may have a decimal value with a granularity of 0.001 seconds. This command is valid for steps 1 thru 20.</p>	<p>C</p>
<pre>:DEFine <step#>, POWERSETTINGS, <watts>, <volts>, <amps>, <ovp>, <s></pre>	<p>Programs the constant power POWERSETTINGS sequence command into the selected sequence at <step#>. The following values define the power setting: constant power limit <watts>,voltage limit<volts>,current limit<amps>,over voltage protection <ovp>, and time duration in <s> seconds. <s> may have a decimal value with a granularity of 0.001 seconds. This command is valid for steps 1 thru 20. If a VIMODE, or a RAMPTOV, or a RAMPTOC command follows the POWERSETTINGS command, then when the POWERSETTINGS command has completed execution, the subsequent command will take control and the constant power mode regulation shall cease. However, if the POWERSETTINGS command is immediately followed by a PAUSE command, then as long as the PAUSE is in effect the constant power mode regulation will continue.</p>	<p>C</p>
<pre>:DEFine <step#>, REPEAT</pre>	<p>Programs the REPEAT sequence command into the selected sequence at <step#>. This sequence command causes sequence execution to jump back to the starting location where sequence execution began, resume execution from there, and continue repeating endlessly. To stop, issue the STOP command. This command is valid for steps 1 thru 20. (To program a finite number of steps to repeat, see the LOOP command).</p>	<p>C</p>
<pre>:DEFine <step#>, SUBCALL, "name"</pre>	<p>Programs the SUBCALL sequence command into the selected sequence at <step#>. The SUBCALL sequence command causes sequence execution to jump to the beginning of a sub-sequence named "name". If the sub-sequence has a RETURN command at its end, then when the RETURN command is encountered, execution will resume at the step immediately following the SUBCALL. This command is valid for steps 1 thru 20.</p>	<p>C</p>
<pre>:DEFine <step#>, RETURN</pre>	<p>Programs the RETURN sequence command into the selected sequence at <step#>. The RETURN sequence command, if it occurs in a sequence that was called with a SUBCALL command, causes execution to resume at the step immediately following the SUBCALL. If the RETURN command occurs in a sequence executed as the primary sequence (i.e., not a sub-sequence), then the RETURN shall be interpreted as though it were a STOP command. The RETURN command is valid for steps 1 thru 21.</p>	<p>C</p>

Command	Description	SCPI
:DEFine <step#>, LOOP,<count>	Programs the LOOP sequence command into the selected sequence at <step#>. The LOOP sequence command, together with its associated <count> value and the NEXT sequence command, provides a means of repeating a set of sequence steps for a defined number of times. All sequence steps that exist between the LOOP sequence command and the NEXT sequence command shall be executed for <count> number of times. It is recommended that the LOOP command and its corresponding NEXT command be in the same named sequence; nevertheless, they may be in different named sequences. The ability to place these two commands in different named sequences allows for the chaining of a number of named sequences together using the GOTO command, and then to put a loop around that entire chain to be repeated a number of times. The LOOP NEXT command pair does support nesting to 10 deep, and the count value must be between 0 and 65535.	C
:DEFine <step#>,NEXT	Programs the NEXT sequence command into the selected sequence at <step#>. The NEXT command must follow a matching LOOP command. The NEXT command causes sequence execution to resume at the matching LOOP command, with a count decreased by 1.	C
:DEFine <step#>,STOP	Programs the STOP sequence command into the selected sequence at <step#>. This sequence command causes sequence execution to stop while the unit remains at the state of the last command within the sequence. This command is valid for steps 1 thru 21. When the PROG:MALLOCATE DEFAULT command is used, a STOP command is automatically loaded into step 21 of that new sequence. This STOP may be overwritten to become a RETURN or GOTO command.	C
:DEFine <step#>,GOTO,"name"	Programs the GOTO sequence command into the selected sequence at <step#>. During sequence execution, the effect of this sequence command is to cause execution to transfer to the beginning of the sequence named "name". This step is valid for steps 1 thru 21. The name must be in double quotes. See the PROG:NAME "name" command for how sequences may be given user defined names.	C
:DEFine <step#>,PAUSE	Programs the PAUSE sequence command into the selected sequence at <step#>. During sequence execution the effect of this command is to cause execution to suspend until a RESUME command is issued to resume execution. This step is valid for steps 1 thru 20.	C
:DEFine? <step#>	Queries the selected sequence for the program contents at step <step#>. The response will read back the step type and defined parameters when programmed. The resolution is defined by the step type.	C
:DELeTe	Program Delete subsystem	C

Command	Description	SCPI
:SElected	Causes the presently selected sequence to be deleted from ram and non-volatile memory. Its previously allocated memory goes back into the memory pool. The memory pool is the memory from which the <code>MALLocate</code> command allocates memory.	C
:ALL	This command causes all defined sequences to be deleted from ram and non-volatile memory.	C
:SAVE	The sub tree for the <code>SAVE</code> commands.	N
:SElected	Saves the presently selected sequence to non-volatile memory for preservation while the power supply is off. Up to 50 sequences a maximum of 20 steps long may be saved.	N
:ALL	Saves all defines sequences to non-volatile memory.	N
:EXECute	The <code>EXECute</code> commands provide a means of explicitly programming the supply to perform a single action that would normally have been done in a sequence step. This in turn provides a means of simulating a sequence. However, each step is significantly slowed by the need to parse the command defining the sequence of actions.	C
:EXECute VIMODE, <volts>, <amps>, <ovp>	Allows setting of active voltage, current, and ovp.	C
:EXECute RAMPTOV, <start volts>,<end volts >, <amps>, <ovp>,<s>	Sets the voltage ramp starting from <start volts> to <end volts> over time period <s> with Values <amps> and <ovp> being set at the beginning of the ramp.	C
:EXECute RAMPTOC, <volts>, <start amps>,<end amps>, <ovp>, <s>	Sets the current ramp starting from <start amps> and going to <end amps> over time period <s> with values <volts> and <ovp> being set at the beginning of the ramp.	C
:EXECute POWERSETTINGS, <watts>, <volts>, <amps>, <ovp>	Command directs the supply to regulate in a constant power mode to a value of <watts> , with a voltage limit of <volts>, current limit of <amps> and with voltage protection setting of <ovp>.	C
:MALLocate DEFAULT	Allocates program memory for a newly named sequence. This command has <i>no</i> effect on already existing sequences, and shall generate an error message if an attempt is made to allocate memory to an already existing sequence. After allocating memory to a newly named sequence, that sequence goes from the EMPTY state to the EDIT state. The state of a sequence may be queried by the <code>PROG:STAT?</code> command. In no case can the total number of sequences exceed 50.	C

Command	Description	SCPI																																																
:NAME "sequence name"	Performs one of two possible actions. Either selects an already existing sequence for use. (See the PROG:CAT? command for a list of saved sequences that may be selected.) Or provides a name for a new sequence. The action that is performed depends upon the "sequence name" and whether it already exists in sequence memory or not. A sequence name must not be longer than 15 characters. After naming a new sequence, the sequence is in the EMPTY state. The next required action to the sequence is to use the MALLOCATE command to allocate memory for the newly named sequence. After the MALLOCATE command is issued, the new sequence goes from the EMPTY state to the EDIT state.	C																																																
:NAME?	Returns the name of the presently selected sequence. If no sequence is presently selected, such as occurs after a *RST command, then the default sequence will be TEST01.	C																																																
:STATE <state name>	<p>Provides a means to change the state of a sequence. The states that may be issued are as follows: RUN, RESUME, PAUSE, STOP, and COMPLETE.</p> <p>A table showing allowable state transitions:</p> <table border="1" data-bbox="667 890 1333 1402"> <thead> <tr> <th data-bbox="667 890 776 1024">requester \ present</th> <th data-bbox="776 890 885 1024">RUN</th> <th data-bbox="885 890 993 1024">RESUME</th> <th data-bbox="993 890 1102 1024">PAUSE</th> <th data-bbox="1102 890 1211 1024">STOP</th> <th data-bbox="1211 890 1333 1024">COMPLETE</th> </tr> </thead> <tbody> <tr> <td data-bbox="667 1024 776 1087">RUNNING</td> <td data-bbox="776 1024 885 1087">*error*</td> <td data-bbox="885 1024 993 1087">*error*</td> <td data-bbox="993 1024 1102 1087">PAUSED</td> <td data-bbox="1102 1024 1211 1087">STOPPED</td> <td data-bbox="1211 1024 1333 1087">*error*</td> </tr> <tr> <td data-bbox="667 1087 776 1150">PAUSED</td> <td data-bbox="776 1087 885 1150">*error*</td> <td data-bbox="885 1087 993 1150">RUNNING</td> <td data-bbox="993 1087 1102 1150">PAUSED</td> <td data-bbox="1102 1087 1211 1150">STOPPED</td> <td data-bbox="1211 1087 1333 1150">*error*</td> </tr> <tr> <td data-bbox="667 1150 776 1213">STOPPED</td> <td data-bbox="776 1150 885 1213">RUNNING</td> <td data-bbox="885 1150 993 1213">*error*</td> <td data-bbox="993 1150 1102 1213">STOPPED</td> <td data-bbox="1102 1150 1211 1213">STOPPED</td> <td data-bbox="1211 1150 1333 1213">*error*</td> </tr> <tr> <td data-bbox="667 1213 776 1276">EDIT</td> <td data-bbox="776 1213 885 1276">*error*</td> <td data-bbox="885 1213 993 1276">*error*</td> <td data-bbox="993 1213 1102 1276">*error*</td> <td data-bbox="1102 1213 1211 1276">*error*</td> <td data-bbox="1211 1213 1333 1276">STOPPED</td> </tr> <tr> <td data-bbox="667 1276 776 1339">EMPTY</td> <td data-bbox="776 1276 885 1339">*error*</td> <td data-bbox="885 1276 993 1339">*error*</td> <td data-bbox="993 1276 1102 1339">*error*</td> <td data-bbox="1102 1276 1211 1339">*error*</td> <td data-bbox="1211 1276 1333 1339">*error*</td> </tr> <tr> <td data-bbox="667 1339 776 1402">ERROR</td> <td data-bbox="776 1339 885 1402">*error*</td> <td data-bbox="885 1339 993 1402">*error*</td> <td data-bbox="993 1339 1102 1402">*error*</td> <td data-bbox="1102 1339 1211 1402">*error*</td> <td data-bbox="1211 1339 1333 1402">*error*</td> </tr> <tr> <td data-bbox="667 1402 776 1465">INITIALIZE</td> <td data-bbox="776 1402 885 1465">*error*</td> <td data-bbox="885 1402 993 1465">*error*</td> <td data-bbox="993 1402 1102 1465">*error*</td> <td data-bbox="1102 1402 1211 1465">*error*</td> <td data-bbox="1211 1402 1333 1465">*error*</td> </tr> </tbody> </table>	requester \ present	RUN	RESUME	PAUSE	STOP	COMPLETE	RUNNING	*error*	*error*	PAUSED	STOPPED	*error*	PAUSED	*error*	RUNNING	PAUSED	STOPPED	*error*	STOPPED	RUNNING	*error*	STOPPED	STOPPED	*error*	EDIT	*error*	*error*	*error*	*error*	STOPPED	EMPTY	*error*	*error*	*error*	*error*	*error*	ERROR	*error*	*error*	*error*	*error*	*error*	INITIALIZE	*error*	*error*	*error*	*error*	*error*	N
requester \ present	RUN	RESUME	PAUSE	STOP	COMPLETE																																													
RUNNING	*error*	*error*	PAUSED	STOPPED	*error*																																													
PAUSED	*error*	RUNNING	PAUSED	STOPPED	*error*																																													
STOPPED	RUNNING	*error*	STOPPED	STOPPED	*error*																																													
EDIT	*error*	*error*	*error*	*error*	STOPPED																																													
EMPTY	*error*	*error*	*error*	*error*	*error*																																													
ERROR	*error*	*error*	*error*	*error*	*error*																																													
INITIALIZE	*error*	*error*	*error*	*error*	*error*																																													

Command	Description	SCPI
:STATe?	<p>Returns the present state for the selected sequence. It returns a state for the RAM copy of the sequence, and a state for the slave processor copy. (Internally, the SGI uses a two processor architecture, where one processor processes the SCPI commands and the user interface (display and keypad), and another processor (the slave processor) processes commands to control the power hardware.) The state of the slave is the actual state of the sequence, since the slave processor actually executes a sequence. The RAM copy will normally reflect the state of the slave. The response of the query is in the following format:</p> <p>Ram{n} = "rstate", slave[m] = "sstate"</p> <p>where rstate may be any of the following:</p> <p style="padding-left: 40px;">"RUNNING", "PAUSED", "STOPPED", "EDIT", "EMPTY", or "ERROR"</p> <p>and sstate may be any of the following:</p> <p style="padding-left: 40px;">"RUNNING", "PAUSED", "STOPPED", or "ERROR"</p>	<p>N</p>

6.13.4 SGI MEASURE SCPI Command Subsystem

The POWER query was added to the Measure subsystem only in SGI to measure power once it is set up. (Section 6.6 contains the Measure commands that can be used in both SGA and SGI):

MEASure:POWer? (Available only with SGI power supplies – see Section 6.13.)

The letter “C” in the “SCPI” column means that the command syntax is SCPI compliant; an “N” in the “SCPI” column means that the command syntax is not part of the SCPI definition.

Command	Description	SCPI
MEASure		N
:POWer?	Returns the value for present power in watts being dissipated by the load. The power is measured by taking voltage and current measurement pairs three times, and averaging the result to a single wattage reading.	N

6.13.5 SGI HTRIGGER SCPI Command Subsystem

This section applies only to units with the External User Interface (Currently only available on Ethernet versions).

The SEQuence command was added to the Htrigger subsystem only in SGI to trigger a preprogrammed ramp or sequence. (Sections 6.10 contains the Htrigger commands that can be used in both SGA and SGI).

HTRIGger:SEQuence (Available only with SGI power supplies – see Section 6.13.)

The letter “C” in the “SCPI” column means that the command syntax is SCPI compliant; an “N” in the “SCPI” column means that the command syntax is not part of the SCPI definition.

Command	Description	SCPI
HTRIGger		N
:SEQuence <string>	Loads a Sequence to be initialized by the external Hardware Trigger. This command must be followed by the HTRIG:ARM command before the Hardware Trigger becomes operational.	N
:SEQuence?	Returns the currently loaded sequence name	N

Command	Description	SCPI
:ARM <boolean>	Readies the last loaded sequence to run when the external Hardware Trigger signal is issued. 1 = Ready to run sequence when Hardware trigger is engaged. 0 = Not Armed, Hardware trigger is ignored NOTE: To arm a different sequence, issue the HTRIG:SEQ command first.	N
:ARM?	Returns the ready status of the last loaded sequence. 1 = Ready to run sequence when Hardware trigger is engaged. 0 = Not Armed, Hardware trigger is ignored NOTE: To load a new sequence to be armed you must issue the HTRIG:SEQ command first.	N

6.14 EXAMPLES OF USING THE SCPI COMMANDS

The following examples demonstrate programming a power supply to control and to readback the output using the SCPI commands. The maximum voltage and current output is dependent on the particular model. The examples list only the SCPI commands; the code required to send the commands is dependent on the type of language you are using (e.g., C or BASIC) and GPIB hardware (e.g., National Instruments).

6.14.1 VI Mode Example

Program a unit with no load at the output to 5 VDC @ 1A, and verify the output.

```
// Use SYST:ERR? after each command to verify no programming errors.
// turn on the unit.
*CLS           // clear the unit to its power-on default settings.
*RST           // reset the unit.
SOUR:CURR 1.0  // program output current to 1.0 A.
SOUR:CURR?    // confirm the output current setting (response: 1.0).
SOUR:VOLT 5.0  // program output voltage to 5.0 VDC.
SOUR:VOLT?    // confirm the output voltage setting (response: 5.0).
MEAS:CURR?    // measure the actual output current (response: ~ 0.0 with no load
              // on output).
MEAS:VOLT?    // measure the actual output voltage (response: ~ 5.0).
```

6.14.2 OVP Setup Example

Program a unit with no load at the output to generate a GPIB service request upon an overvoltage protection trip condition. (Must use GPIB not RS232.)

```
// Use SYST:ERR? after each command to verify no programming errors.
// assure that PON is not selected on the rear panel switch.
```

```

// Turn on the unit.
*CLS // clear the unit to its power-on default settings.
*RST // reset the unit.
SOUR:VOLT:PROT 4.0 // program the OVP trip point to 4.0 VDC.
SOUR:VOLT:PROT? // confirm the OVP trip point setting (response: 4.0).
SOUR:CURREN 1.0 // program output current to 1.0 A.
SOUR:VOLT 3.0 // program output voltage to 3.0 VDC.
STAT:PROT:ENABLE 8 // program the unit to report OVP trip.
STAT:PROT:ENABLE? // confirm that OVP fault is enabled (response: 8).
*SRE 2 // enable the GPIB service request upon a fault.
*SRE? // confirm the GPIB service request enabled (response 2).
STAT:PROT:EVENT? // confirm no faults occurred (response: 0).
// confirm that the OVP led and SRQ led is not active.
SOUR:VOLT 7.0 // program output voltage to 7.0 VDC - cause OVP trip!
// confirm that unit issued a GPIB service request (use a serial
poll).

```

6.14.3 Trigger Example

Program a unit with no load at the output to change its output voltage and current to 5 VDC @ 1A at the same time.

```

// Use SYST:ERR? after each command to verify no programming errors.
// turn on the unit.
*CLS // clear the unit to its power-on default settings.
*RST // reset the unit.
SOUR:CURREN:TRIG 1.0 // program output current to 1.0 A upon trigger.
SOUR:CURREN:TRIG? // confirm output current set to 1.0 A upon trigger.
SOUR:VOLT:TRIG 5.0 // program output voltage to 5.0 VDC upon trigger
SOUR:VOLT:TRIG? // confirm output current set to 5.0 VDC upon trigger.
MEAS:CURREN? // measure the actual output current (response: 0.0).
MEAS:VOLT? // measure the actual output voltage (response: 0.0).
TRIG:TYPE 3 // trigger the unit to implement curr and volt programming.
MEAS:CURREN? // measure the actual output current (response: ~ 0. 0 with no
load on output).
MEAS:VOLT? // measure the actual output voltage (response: ~ 5.0).
TRIG:ABORT // turn off trigger mode.

```

6.14.4 Hardware Trigger Example

This example applies only to units with the External User Interface (Currently only available on Ethernet versions).

Program a unit to execute a test sequence “TEST02” when a hardware trigger is issued using the External User Interface (the sequence must be programmed before it can be loaded).

```
HTRIG:SEQ "TEST02" // load the sequence named "TEST02" into memory.
HTRIG:SEQ? // verify that "TEST02" was loaded.
HTRIG:ARM 1 // arm the hardware trigger.
HTRIG:ARM? // verify that the hardware trigger was armed.
// invoke the hardware trigger.
// sequence "TEST02" will run.
PROG:STAT? // verify that the sequence is running or finished.
```

6.14.5 Ramp V Example

Program a unit with no load at the output to ramp its output voltage from 5 VDC to 25 VDC in 30 seconds.

Note: *The maximum output voltage is dependent upon the power supply rating.*

```
// Use SYST:ERR? after each command to verify no programming errors.
// turn on the unit.
*CLS // clear the unit to its power-on default settings.
*RST // reset the unit.
SOUR:CURR 33.0 // program output current to 33.0 A.
SOUR:VOLT 5.0 // program output voltage to 5.0 VDC.
SOUR:VOLT:RAMP 25.0 30.0 // program voltage to ramp from the present
// value (5.0 VDC) to 25.0 VDC in 30 seconds.
```

6.14.6 Ramp I Example

Program a unit with the output shorted to ramp its output current from 5A to 25A in 30 seconds.

```
// Use SYST:ERR? after each command to verify no programming errors.
// turn on with no load at the output.
*CLS // clear the unit to its power-on default settings.
*RST // reset the unit.
// short the output.
SOUR:VOLT 33.0 // program output voltage to 33.0 VDC.
```

```

SOUR:CURREN 5.0 // program output current to 5.0 A.
SOUR:CURREN:RAMP 25.0 30.0 // program current to ramp from the present
// value (5.0 A) to 25.0 A in 30 seconds.

```

6.14.7 Ramp V Example 2

Program a unit with no load at the output, to ramp its output voltage from 5 VDC to 25 VDC in 30 seconds upon the trigger command.

```

// Use SYST:ERR? after each command to verify no programming errors.
// turn on the unit.
*CLS // clear the unit to its power-on default settings.
*RST // reset the unit.
SOUR:CURREN 33.0 // program output current to 33.0 A.
SOUR:VOLT 5.0 // program output voltage to 5.0 VDC.
SOUR:VOLT:RAMP:TRIG 25.0 30.0 // program voltage to ramp from the present
// value (5.0 VDC) to 25.0 VDC in 30 secs.
// upon the trigger command.
TRIG:RAMP // start ramp execution.
TRIG:ABORT // turn off trigger mode.

```

6.14.8 Power On INIT Example

Program a unit to power-on and initialize to 2 VDC @ 1A with an overvoltage protection level of 3 VDC. Verify proper power-on initialization.

```

// Use SYST:ERR? after each command to verify no programming errors.
// turn on the unit.
*CLS // clear the unit to its power on default settings.
*RST // reset the unit.
CAL:INIT:CURREN 1.0 // set power-on initial current to 1.0 A.
CAL:INIT:CURREN? // confirm power-on initial current setting.
CAL:INIT:VOLT 2.0 // set power-on initial voltage to 2.0 VDC.
CAL:INIT:VOLT? // confirm power-on initial voltage setting.
CAL:INIT:VOLT:PROT 3.0 // set power-on initial overvoltage protection to 3.0 VDC.
CAL:INIT:VOLT:PROT? // confirm power-on initial overvoltage protection setting.
CAL:UNLOCK "6867" // unlock nonvolatile memory for calibration value storage.
CAL:STORE // store the calibration values in nonvolatile memory.
CAL:LOCK // lock nonvolatile memory for calibration value protection.
// cycle power to the unit.
// note voltage is initialized to 2.0 VDC via front panel.

```

```

SOUR:CURR?           // confirm power-on initial current setting.
SOUR:VOLT?           // confirm power-on initial voltage setting.
SOUR:VOLT:PROT?     // confirm power-on initial overvoltage protection setting.

```

6.14.9 Sequence Creation and Execution Examples

These examples assume that the sequence memory is empty. In other words, no sequences are presently defined. If you are doing these examples for a second time, then the sequence memory must first be cleared. Clear all sequence memory by issuing the command `PROG:DEL:ALL`.

Delete all sequences from non-volatile memory using the following command:

```
PROG:DEL:ALL
```

EXAMPLE 1

Issue `*RST` to reset the unit to a known state.

To create a sequence named “SEQ1”, first issue the `NAME` command as follows:

```
PROG:NAME "SEQ1"
```

If you query the state of the selected sequence, it responds `EMPTY`.

```
PROG:STAT?
```

Response: “EMPTY”

Then memory needs to be allocated to the newly named SEQ1 sequence:

```
PROG:MALL DEFAULT
```

After memory has been allocated, the state of the SEQ1 sequence is `EDIT`, as the following query shows:

```
PROG:STAT?
```

Response: “EDIT”

Once the sequence is in the `EDIT` state, we are ready to send a sequence of programming steps to define a sequence of power supply settings:

```

PROG:DEF 1, VIMODE,3,4,11,10 //go to 3 volts, 4 amps, 11 volts ovp, for 10 seconds
PROG:DEF 2, RAMPTOV,3,5,4,11,10 //ramp from 3 to 5 volts in 10 sec.
PROG:DEF 3, VIMODE, 5, 4, 11, 10 //hold 5 volts for 10 seconds
PROG:DEF 4, RAMPTOV, 5, 3, 4, 11, 10 //ramp from 5 to 3 volts in 10 sec.
PROG:DEF 5, VIMODE, 3, 4, 11, 10 //hold 3 volts for 10 seconds
PROG:DEF 6, STOP //stops running the sequence while the unit
//remains at the state of the last command
//within the sequence.

```

Only 6 steps are intended for this example, so the sequence is complete. To take the sequence out of the EDIT state, it needs to be sent to the COMPLETE state, which becomes the STOPPED state, using the following command:

```

PROG:STAT COMPLETE

PROG:SAVE:SEL

PROG:STAT?

```

Response: Ram[0]="STOPPED",Slave[0]="STOPPED"

Once in the STOPPED state, the sequence is ready to run again. To rerun the sequence, issue the following two commands:

```

OUTP:STAT ON

PROG:STATE RUN

```

The sequence should run, and the output of the power supply for Example 1 should look like the following:

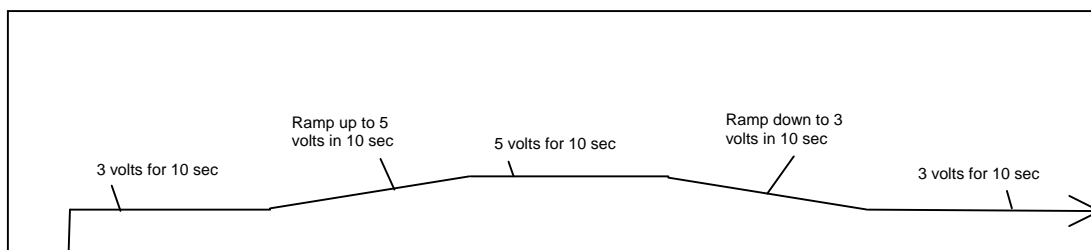

Figure 6-1. Power Supply Output for Example 1

Leave SEQ1 in the power supply's sequence memory, and create a second example sequence to also keep in sequence memory. (There is enough memory for a total of 50 different sequences.)

EXAMPLE 2

Issue *RST to establish a known state.

```

PROG:NAME "SEQ2"

PROG:MALL DEFAULT

PROG:DEF 1, VIMODE,10,4,11,5 //go to 10 volts, 4 amps, 11 volts ovp, for 5
                             seconds
PROG:DEF 2, RAMPTOV,10,2,4,11,9 //ramp from 10 volts down to 2 volts in 10 seconds
PROG:DEF 3, RETURN

PROG:STAT COMPLETE

PROG:SAVE:SEL

PROG:STAT?
    
```

Response: Ram[22]="STOPPED",Slave[22]="STOPPED"

(Notice in this example the sequence is being ended with a RETURN rather than a STOP. A RETURN is more flexible because it automatically acts like a stop when SEQ2 is run directly; and yet, if SEQ2 is run as a sub-sequence, then the RETURN shall act as a statement to return to the calling sequence.)

To run SEQ2 directly, issue the command as before:

```

OUTP:STAT ON

PROG:STAT RUN
    
```

For the running sequence, the power supply output for Example 2 should look like the following:

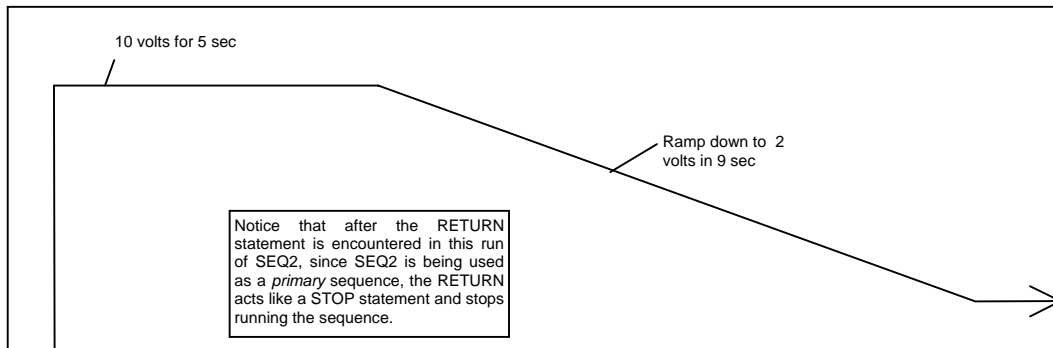

Figure 6-2. Power Supply Output for Example 2

Once the ramp goes down to 2 volts, the sequence stops and the unit remains at the state of the last command within the sequence.

EXAMPLE 3

Issue *RST to establish a known state.

In this third example, redefine SEQ1 so that it calls SEQ2 as a subroutine.

To modify SEQ1 requires that it be deleted, and re-written. Overwriting a completed, existing sequence is not allowed by the SCPI command interface for code readability reasons. Even though overwriting is not permitted, re-writing is permitted after a sequence has been deleted. Delete the SEQ1 sequence as follows:

```
PROG:NAME "SEQ1"
```

```
PROG:DEL:SEL
```

That deletes SEQ1.

Now create a new SEQ1 that calls SEQ2 as a subsequence.

```
PROG:NAME "SEQ1"
```

```
PROG:MALL DEFAULT
```

```
PROG:DEF 1, VIMODE, 3, 4, 11, 10 //go to 3 volts, 4 amps, 11 volts ovp, for 10 sec
```

```
PROG:DEF 2, RAMPTOV, 3, 5, 4, 11, 10 //ramp from 3 volts to 5 volts in
10 sec
```

```
PROG:DEF 3, VIMODE, 5, 4, 11, 10 //hold 5 volts for 10 sec
```

```
PROG:DEF 4, RAMPTOV, 5, 3, 4, 11, 10 //ramp from 5 volts to 3 volts in
10 sec
```

```
PROG:DEF 5, VIMODE, 3, 4, 11, 10 //hold 3 volts for 10 sec
```

```
PROG:DEF 6, SUBCALL, "SEQ2" //call SEQ2 as a subsequence
```

```
PROG:DEF 7, VIMODE, 4, 5, 11, 6 //go to 4 volts, 5 amps, 11 volts ovp, for 6
sec
```

```
PROG:DEF 8, STOP //stop running the sequence while
the unit remains at the state of the
last command within the
sequence.
```

```
PROG:STAT COMPLETE
```

```
PROG:SAVE:SEL
```

```
PROG:STAT?
```

Response: Ram[0]="STOPPED",Slave[0]="STOPPED"

```
OUTP:STAT ON
```

```
PROG:STAT RUN
```

The output of the supply for Example 3 should look like the following diagram:

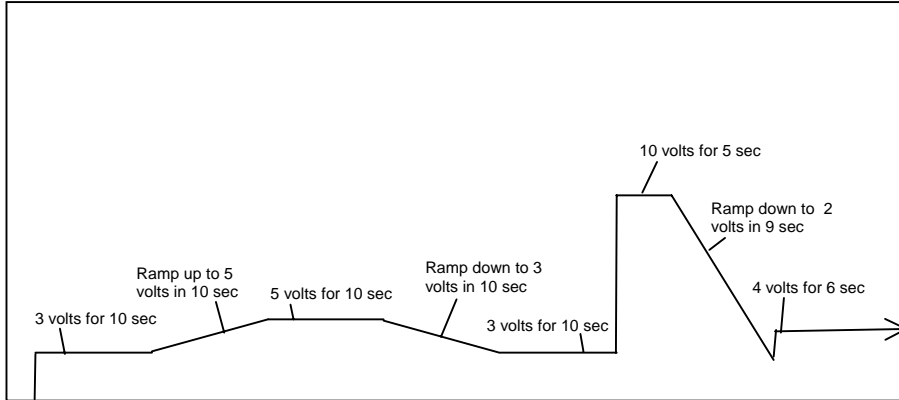

Figure 6-3. Power Supply Output for Example 3

The above diagram shows how the new SEQ1 sequence looks when SEQ2 is installed as a subsequence.

EXAMPLE 4

Issue *RST to establish a known state.

In this example, create a sequence that pauses at its end to let the last settings remain in effect. To do this use the PAUSE command.

Now create a new SEQ3:

```
PROG:SEL:NAME "SEQ3"
PROG:MALL DEFAULT
PROG:DEF 1, VIMODE, 3, 4, 11, 10 //go to 3 volts, 4 amps, 11 volts ovp, for
                               10 sec
PROG:DEF 2, RAMPTOV, 3, 5, 4, 11, 10 //ramp from 3 volts to 5 volts in 10 sec
PROG:DEF 3, VIMODE, 5, 4, 11, 10 //hold 5 volts for 10 sec
PROG:DEF 4, RAMPTOV, 5, 3, 4, 11, 10 //ramp from 5 volts to 3 volts in 10 sec
PROG:DEF 5, VIMODE, 3, 4, 11, 10 //hold 3 volts for 10 sec
PROG:DEF 6, SUBCALL, "SEQ2" //call SEQ2 as a subsequence
PROG:DEF 7, VIMODE, 4, 5, 11, 6 //go to 4 volts, 5 amps, 11 volts ovp, for 6 sec
PROG:DEF 8, PAUSE //allow the output to remain at the last setting
```

```
PROG:DEF 9, STOP
```

//stop running the sequence while the unit remains at the state of the last command within the sequence.

```
PROG:STAT COMPLETE
```

```
PROG:SAVE:SEL
```

```
PROG:STAT?
```

Response: Ram[44]="STOPPED",Slave[44]="STOPPED"

```
OUTP:STAT ON
```

```
PROG:STAT RUN
```

Following is a diagram for Example 4.

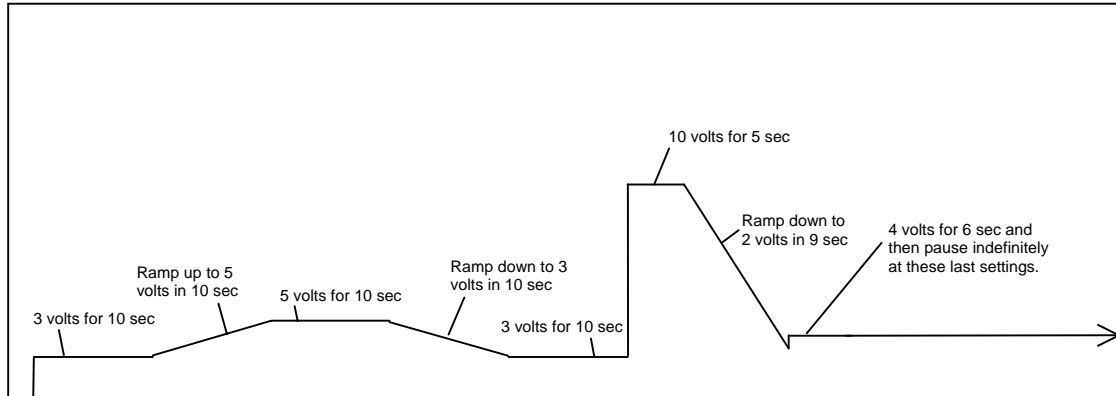

Figure 6-4. End-of-Sequence Pause for Example 4

EXAMPLE 5

To make a sequence longer than the maximum of 20 steps in an ordinary sequence, there are either one of two ways or a combination of the two. One way is to use the `SUBCALL` command. The second way is to use the `GOTO` command. The use of the `SUBCALL` command was shown in Examples 3 and 4 above. Now join two 20-step sequences with a `GOTO` command.

First, create a sequence wherein the power supply output will simulate a capacitor charge curve to a maximum of 10 volts and discharge curve to zero volts.

The formula for charging is $10(1 - e^{-\frac{t}{RC}})$.

Issue *RST to establish a known state.

```

PROG:NAME "Charge" //This sequence will simulate an
RC=1 charge curve

PROG:MALL DEFAULT

PROG:DEF 1, VIMODE, 0, 5, 20, 1 //go to 0 volts for 1 second
PROG:DEF 2, RAMPTOV, 0, 0.95, 5, 20, 0.1 //ramp from 0 to 0.95 volts in 0.1 sec
PROG:DEF 3, RAMPTOV, 0.95, 1.81, 5, 20, 0.1 //ramp from 0.95 volts to 1.81 volts
in 0.1sec
PROG:DEF 4, RAMPTOV, 1.81, 2.59, 5, 20, 0.1 //ramp from 1.81 volts to 2.59 volts
in 0.1sec
PROG:DEF 5, RAMPTOV, 2.59, 3.30, 5, 20, 0.1 //ramp from 2.59 volts to 3.30 volts
in 0.1sec
PROG:DEF 6, RAMPTOV, 3.30, 3.93, 5, 20, 0.1 //ramp from 3.30 volts to 3.93 volts
in 0.1sec
PROG:DEF 7, RAMPTOV, 3.93, 4.51, 5, 20, 0.1 //ramp from 3.93 volts to 4.51 volts
in 0.1 sec
PROG:DEF 8, RAMPTOV, 4.51, 5.03, 5, 20, 0.1 //ramp from 4.51 volts to 5.03 volts
in 0.1 sec
PROG:DEF 9, RAMPTOV, 5.03, 5.51, 5, 20, 0.1 //ramp from 5.03 volts to 5.51 volts
in 0.1 sec
PROG:DEF 10, RAMPTOV, 5.51, 5.93, 5, 20, 0.1 //ramp from 5.51 volts to 5.93 volts
in 0.1 sec
PROG:DEF 11, RAMPTOV, 5.93, 6.32, 5, 20, 0.1 //ramp from 5.93 volts to 6.32 volts
in 0.1 sec
PROG:DEF 12, RAMPTOV, 6.32, 6.67, 5, 20, 0.1 //(ramp from 6.32 volts to 6.67 volts
in 0.1 sec
PROG:DEF 13, RAMPTOV, 6.67, 6.99, 5, 20, 0.1 //ramp from 6.67 volts to 6.99 volts
in 0.1 sec
PROG:DEF 14, RAMPTOV, 6.99, 7.27, 5, 20, 0.1 //ramp from 6.99 volts to 7.27 volts
in 0.1 sec
PROG:DEF 15, RAMPTOV, 7.27, 7.53, 5, 20, 0.1 (ramp from 7.27 volts to 7.53
volts in 0.1 sec)
PROG:DEF 16, RAMPTOV, 7.53, 7.77, 5, 20, 0.1 (ramp from 7.53 volts to 7.77

```

```

volts in 0.1 sec)
PROG:DEF 17, RAMP TOV, 7.77, 7.98, 5, 20, 0.1 (ramp from 7.77 volts to 7.98
volts in 0.1 sec)
PROG:DEF 18, RAMP TOV, 7.98, 8.17, 5, 20, 0.1 (ramp from 7.98 volts to 8.17
volts in 0.1 sec)
PROG:DEF 19, RAMP TOV, 8.17, 8.31, 5, 20, 0.1 (ramp from 8.17 volts to 8.31
volts in 0.1 sec)
PROG:DEF 20, RAMP TOV, 8.31, 8.50, 5, 20, 0.1 (ramp from 8.31 volts to 8.50
volts in 0.1 sec)
PROG:DEF 21, GOTO, "Discharge" (step 21 may only be a STOP,
RETURN, or GOTO)

PROG:DEF 22, STOP
PROG:STAT COMPLETE
PROG:SAVE:SEL
PROG:STAT?

```

Response: Ram[66]="STOPPED",Slave[66]="STOPPED"

The formula for discharging is $Ae^{-\frac{t}{RC}}$, where A is the calculated amplitude achieved by the previous charge cycle.

```

PROG:NAME "Discharge"
PROG:MALL DEFAULT
PROG:DEF 1, RAMP TOV, 8.50, 7.69, 5, 20, 0.1 //ramp from 8.50 volts down to
7.69 volts in 0.1 sec
PROG:DEF 2, RAMP TOV, 7.69, 6.95, 5, 20, 0.1 //ramp from 7.69 volts down to
6.95 volts in 0.1 sec
PROG:DEF 3, RAMP TOV, 6.95, 6.29, 5, 20, 0.1 //ramp from 6.95 volts down to
6.29 volts in 0.1 sec
PROG:DEF 4, RAMP TOV, 6.29, 5.70, 5, 20, 0.1 //ramp from 6.29 volts down to
5.70 volts in 0.1 sec
PROG:DEF 5, RAMP TOV, 5.70, 4.66, 5, 20, 0.1 //ramp from 5.70 volts down to
4.66 volts in 0.1 sec
PROG:DEF 6, RAMP TOV, 4.66, 4.22, 5, 20, 0.1 //ramp from 4.66 volts down to
4.22 volts in 0.1 sec
PROG:DEF 7, RAMP TOV, 4.22, 3.82, 5, 20, 0.1 //ramp from 4.22 volts down
to 3.82 volts in 0.1 sec

```

```
PROG:DEF 8, RAMPTOV, 3.82, 3.46, 5, 20, 0.1 //ramp from 3.82 volts down
to 3.46 volts in 0.1 sec
PROG:DEF 9, RAMPTOV, 3.46, 3.12, 5, 20, 0.1 //ramp from 3.46 volts down
to 3.12 volts in 0.1 sec
PROG:DEF 10,RAMPTOV, 3.12, 2.83, 5, 20, 0.1 //ramp from 3.12 volts down to
2.83 volts in 0.1 sec
PROG:DEF 11,RAMPTOV, 2.83, 2.56, 5, 20, 0.1 //ramp from 2.83 volts down to
2.56 volts in 0.1 sec
PROG:DEF 12,RAMPTOV, 2.56, 2.31, 5, 20, 0.1 //ramp from 2.56 volts down to
2.31 volts in 0.1 sec
PROG:DEF 13,RAMPTOV, 2.31, 2.10, 5, 20, 0.1 //ramp from 2.31 volts down to
2.10 volts in 0.1 sec
PROG:DEF 14,RAMPTOV, 2.10, 1.90, 5, 20, 0.1 //ramp from 2.10 volts down to
1.90 volts in 0.1 sec
PROG:DEF 15,RAMPTOV, 1.90, 1.72, 5, 20, 0.1 //ramp from 1.90 volts down to
1.72 volts in 0.1 sec
PROG:DEF 16,RAMPTOV, 1.72, 1.55, 5, 20, 0.1 //ramp from 1.72 volts down to
1.55 volts in 0.1 sec
PROG:DEF 17,RAMPTOV, 1.55, 1.40, 5, 20, 0.1 //ramp from 1.55 volts down to
1.40 volts in 0.1 sec
PROG:DEF 18,RAMPTOV, 1.40, 1.27, 5, 20, 0.1 //ramp from 1.40 volts down to
1.27 volts in 0.1 sec
PROG:DEF 19,RAMPTOV, 1.27, 1.15, 5, 20, 0.1 //ramp from 1.27 volts down to
1.15 volts in 0.1 sec
PROG:DEF 20,RAMPTOV, 1.15, 1.04, 5, 20, 0.1 //ramp from 1.15 volts down
to 1.04 volts in 0.1 sec
PROG:DEF 21, RETURN //step 21 may only be a STOP,
RETURN, or GOTO
PROG:STAT COMPLETE
PROG:SAVE:SEL
PROG:STAT?
```

Response: Ram[88]="STOPPED",Slave[88]="STOPPED"

To run the combined sequence, simply select the first sequence, and then run it.

```
PROG:NAME "Charge"
```

```
OUTP:STAT ON
```

```
PROG:STAT RUN
```

The output for Example 5 should look like the following diagram:

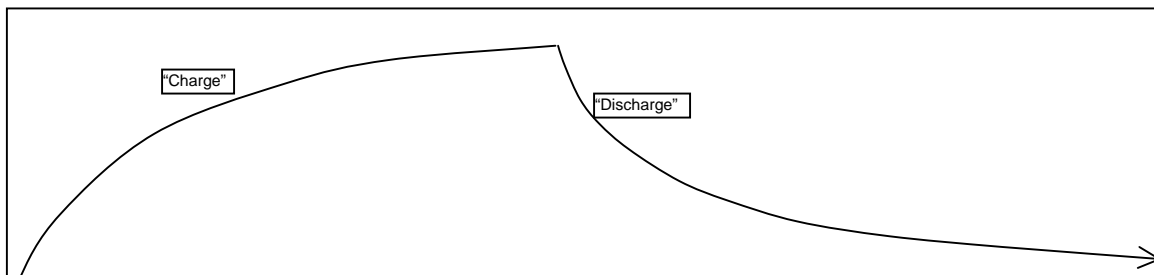

Figure 6-5. Power Supply Output for Example 5

EXAMPLE 6

This example shows how to make an infinite loop for the creation of a continuous square wave:

Issue *RST to establish a known state.

```
PROG:NAME "Square Wave"
```

```
PROG:MALL DEFAULT
```

```
PROG:DEF 1, VIMODE, 0, 5, 15, 0.5 //go to 0 volts, 5 amps, 15 volts ovp, for  
0.5 seconds
```

```
PROG:DEF 2, VIMODE, 10,5,15,0.5 //go to 10 volts, 5 amps, 15 volts ovp, for  
0.5 seconds
```

```
PROG:DEF 3,GOTO, "Square Wave" //go to top of this sequence and loop  
indefinitely)
```

```
PROG:STAT COMPLETE
```

```
PROG:SAVE:SEL
```

```
PROG:STAT?
```

Response: Ram[110]="STOPPED",Slave[110]="STOPPED"

```
OUTP:STAT ON
```

```
PROG:STAT RUN
```

The output for Example 6 should look something like the following:

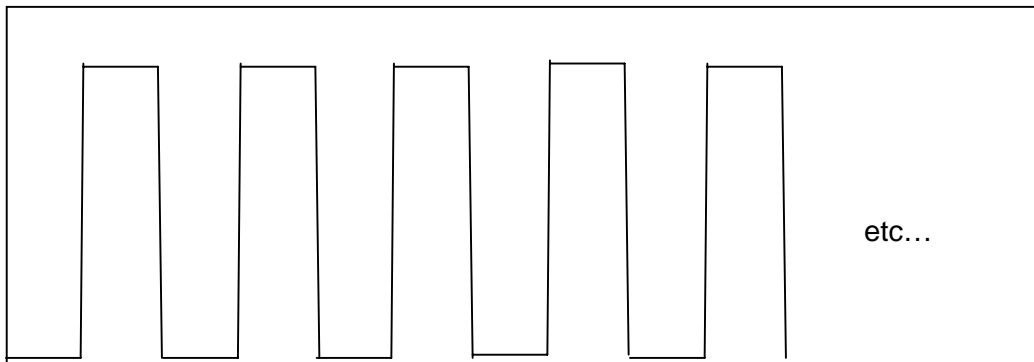

Figure 6-6. Power Supply Output for Example 6

To stop the execution of the square wave sequence, issue the STOP state command:

```
PROG:STAT STOP
```

The sequence should stop running while the unit remains at the state of the last command within the sequence.

To pause instead of stop, issue the PAUSE state command instead:

```
PROG:STAT PAUSE
```

After pausing, the output will remain at its present value.

EXAMPLE 7

This example shows how to make a definite length square wave (as opposed to an infinite length square wave) that has a specified number of cycles.

Issue *RST to establish a known state.

```
PROG:NAME "Pulse Train"  
PROG:MALL DEFAULT  
PROG:DEF 1, VIMODE, 0, 5, 15, 1  
PROG:DEF 2, RAMPTOV, 0, 4, 5, 15, 1  
PROG:DEF 3, LOOP, 10  
PROG:DEF 4, VIMODE, 4, 5, 15, 1  
PROG:DEF 5, VIMODE, 0, 5, 15, 1  
PROG:DEF 6, NEXT  
PROG:DEF 7, VIMODE, 4, 5, 15, 1  
PROG:DEF 8, RAMPTOV, 4, 0, 5, 15, 1  
PROG:DEF 9, STOP  
PROG:STAT COMPLETE  
PROG:SAVE:SEL  
PROG:STAT?
```

Response: Ram[132]="STOPPED",Slave[132]="STOPPED"

OUTP:STAT ON

PROG:STAT RUN

The power supply output for Example 7 should look something like the following:

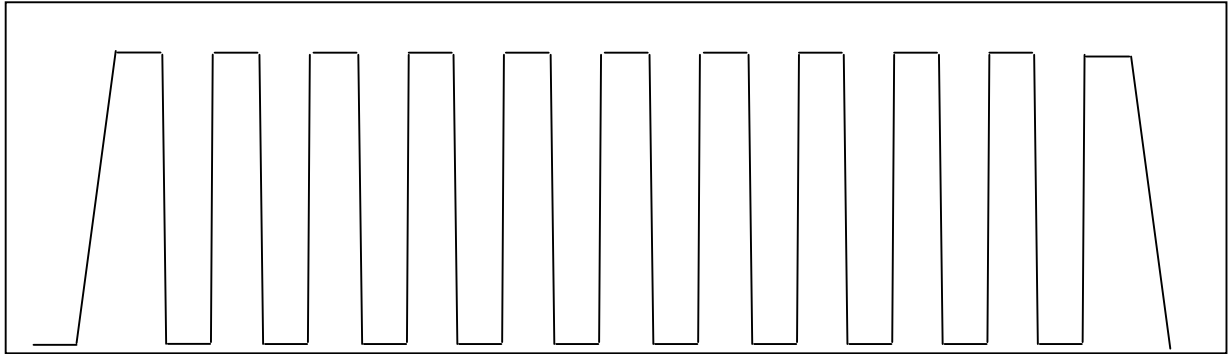

Figure 6-7. Power Supply Output for Example 7

This page intentionally left blank.

SECTION 7 CALIBRATION



CAUTION

Please refer to the power supply operation manual for further information before performing calibration procedures. Only qualified personnel who deal with attendant hazards in power supplies, are allowed to perform calibration procedures. If calibration is not performed properly, functional problems could arise, requiring that the supply be returned to the factory.

7.1 INTRODUCTION

The Digital Interface Adapter (DIA) for IEEE 488.2 (GPIB), for RS232, or for Ethernet, is calibrated to adjust internal signal levels to correspond to the expected supply output signal levels. You must perform the calibration procedures if the power supply's programming or readback performance falls out of specification due to component aging drifts. Refer to your power supply operation manual to find the required calibration interval. The DIA is calibrated for output voltage programming, output current programming, output overvoltage protection programming, voltage readback, and current readback.

The calibration procedures in the following sections are designed to be performed at ambient temperature of $25^{\circ}\text{C} \pm 5^{\circ}\text{C}$, after the unit has had a stable output and a stable load for at least 30 minutes.

The following test equipment is required in addition to the computer system to complete the following calibration:

- Model HP 344401A or equivalent 6-digit digital voltmeter (DVM)
- Current shunt rated for an accuracy of 0.25% or better and a minimum of 125% of the UUT full scale output current

NOTE: The calibration procedures in the following sections are applicable either to Ethernet only or to Ethernet and GPIB as noted in each section heading. All calibration procedures steps should be performed. Omitting any step or applicable section may affect the specified performance of the unit.

The CAL:DATE (for GPIB) command or the CAL:MOD:LASTCALDATE and CAL:MOD:NEXTCALDATE (for Ethernet) commands (Section 6.12) should

be issued once calibration procedures have been performed.

7.2 SETUP FOR CALIBRATION

This section provides calibration setup for GPIB, RS232 and Ethernet; note that Step 6 provides separate instructions for each control interface.

STEP DESCRIPTION

1. Disconnect the Unit Under Test (UUT) AC input power. (The UUT is the power supply that will be calibrated.)
2. Disconnect all loads from the UUT's output terminals.
3. Connect the UUT sense lines to the output terminals. Refer to the power supply operation manual for further information on remote sensing.
4. Connect the DVM to the UUT output terminals.
5. Set the UUT to REMOTE mode by the rear panel S1 DIP switch.
6. Perform one of the following:

For **GPIB**:

Ensure that the correct GPIB primary address has been set by the UUT rear panel DIP switches for SGA or via the UUT front panel Remote menu for SGI. Connect the GPIB controller to the rear panel of the UUT using a GPIB cable.

For **RS232**:

Connect the RS232 controller to the rear panel of the UUT using the RS232 null modem cable (see Figure 3-4 of this manual).

For **Ethernet**:

Refer to Section 5.2 of this manual for Ethernet communication setup.

Connect the RJ-45 Ethernet cable to the rear panel of the UUT.

7. Reconnect the AC input power. Turn the unit ON and allow the unit to warm up for at least 30 minutes.

The UUT is ready for the calibration procedure to be performed.



WARNING

Exercise caution when using and servicing power supplies:

- High energy levels can be present at the output terminals on all power supplies in normal operation.
- Potentially lethal voltages exist within the power supply and on the output terminals of power supplies that are rated at 40V and over.
- Filter capacitors store potentially dangerous energy for some time after power is removed.

7.3 VOLTAGE PROGRAMMING CALIBRATION (ETHERNET)

STEP DESCRIPTION

1. Issue a *CLS command.
2. Issue a *RST command.
3. Program the overvoltage protection to maximum to prevent nuisance trips:

`CAL:OUTP:VOLT:PROT:DAC 65535`
4. Program the output current to full scale to prevent Constant-Current operation:

`CAL:OUTP:CURR:DAC 65535`
5. Program the output of the first calibration point by sending the following command string from the computer:

`CAL:OUTP:VOLT:DAC 3275`
6. Let the output settle and measure the voltage with a high precision voltmeter; this is value 1.
7. Enter the actual output voltage value of the first calibration point:

`CAL:OUTP:VOLT:FIVEPOINT 1 <value 1>`
8. Program the output of the second calibration point by sending the following command string from the computer:

`CAL:OUTP:VOLT:DAC 19000`
9. Let the output settle and measure the voltage with a high precision voltmeter; this is value 2.
10. Enter the actual output voltage value of the second calibration point:

`CAL:OUTP:VOLT:FIVEPOINT 2 <value 2>`
11. Program the output of the third calibration point by sending the following command string from the computer:

`CAL:OUTP:VOLT:DAC 32000`
12. Let the output settle and measure the voltage with a high precision voltmeter; this is value 3.

13. Enter the actual output voltage value of the third calibration point:

```
CAL:OUTP:VOLT:FIVEPOINT 3 <value 3>
```

14. Program the output of the fourth calibration point by sending the following command string from the computer:

```
CAL:OUTP:VOLT:DAC 45000
```

15. Let the output settle and measure the voltage with a high precision voltmeter; this is value 4.

16. Enter the actual output voltage value of the fourth calibration point:

```
CAL:OUTP:VOLT:FIVEPOINT 4 <value 4>
```

17. Program the output of the fifth calibration point by sending the following command string from the computer:

```
CAL:OUTP:VOLT:DAC 62250
```

18. Let the output settle and measure the voltage with a high precision voltmeter; this is value 5.

19. Enter the actual output voltage value of the fifth calibration point:

```
CAL:OUTP:VOLT:FIVEPOINT 5 <value 5>
```

20. To review entered data for five–point voltage calibration, issue the following query:

```
CAL:OUTP:VOLT:FIVEPOINT?
```

21. Program the supply to unlock the non-volatile memory for calibration value storage:

```
CAL:UNLOCK "6867"
```

22. Program the supply to store the calibration values in non-volatile memory:

```
CAL:STORE
```

Allow 15 seconds for the non-volatile memory to be updated with the new calibration values.

23. Program the supply to lock the non-volatile memory for calibration value protection.

```
CAL:LOCK
```

7.4 VOLTAGE PROGRAM GAIN/OFFSET AND MEASUREMENT READBACK CALIBRATION (ETHERNET, GPIB)

NOTE: This calibration procedure is required in order to use Constant Power Mode programming.

STEP DESCRIPTION

1. Program the overvoltage protection to maximum to prevent nuisance trips:

```
CAL:OUTP:VOLT:PROT:DAC 65535
```

2. Program the output current to full scale to prevent Constant-Current operation:

```
CAL:OUTP:CURR:DAC 65535
```

3. Program the output of the first calibration point to approximately 15% of full scale voltage by sending the following command string from the computer:

```
CAL:OUTP:VOLT:DAC 9830
```

4. Let the output settle and measure the voltage with the meter.
5. Enter the actual voltage readback corresponding to the DAC value 9830 of the first calibration point:

```
CAL:OUTP:VOLT:POINT 1 <voltage>  
CAL:MEAS:VOLT:POINT 1 <voltage>
```

6. Program the output of the second calibration point to approximately 85% of full scale voltage by sending the following command string from the computer:

```
CAL:OUTP:VOLT:DAC 55700
```

7. Let the output settle and measure the voltage with the meter.
8. Enter the actual voltage readback corresponding to the DAC value 5570 of the second calibration point:

```
CAL:OUTP:VOLT:POINT 2 <voltage>  
CAL:MEAS:VOLT:POINT 2 <voltage>
```

9. Reset the output voltage to 0 volts.

```
CAL:OUTP:VOLT:DAC 0
```

10. Program the Digital Interface Adapter (DIA) to calculate the voltage readback calibration gain and offset values:

```
CAL:OUTP:VOLT:CALC  
CAL:MEAS:VOLT:CALC
```

11. Program the DIA to unlock the non-volatile memory for calibration value storage:

```
CAL:UNLOCK "6867"
```

12. Program the DIA to store the calibration values in non-volatile memory:

```
CAL:STORE
```

Allow 15 seconds for the non-volatile memory to be updated with the new calibration values.

13. Program the DIA to lock the non-volatile memory for calibration value protection:

```
CAL:LOCK
```

7.5 OVERVOLTAGE PROTECTION PROGRAMMING CALIBRATION (ETHERNET, GPIB)

The overvoltage protection calibration procedure requires calibrated output voltage programming and voltage readback for proper function.

STEP DESCRIPTION

1. Program the DIA to self-calibrate the overvoltage protection:

```
CAL:OUTP:VOLT:PROT:CALC
```

The overvoltage protection calibration function requires over 30 seconds. Use *ESE 1 and serial polls to detect when calibration is done.

2. Program the DIA to unlock the non-volatile memory for calibration value storage:

```
CAL:UNLOCK "6867"
```

3. Program the DIA to store the calibration values in non-volatile memory:

```
CAL:STORE
```

Allow 15 seconds for the non-volatile memory to be updated with the new calibration values.

4. Program the DIA to lock the non-volatile memory for calibration value protection

```
CAL:LOCK
```

7.6 CURRENT PROGRAMMING CALIBRATION (ETHERNET)

Preparation:

1. Power down the Unit Under Test (UUT) and remove the input power for safety.
2. Allow 5 minutes for the energy in the output to bleed down to a safe level.
3. Attach the precision shunt between the power supply's output terminals.
4. Attach the voltmeter across the shunt.
5. Apply input power and power up the UUT.
6. After the UUT has initialized, begin the calibration procedure.

STEP DESCRIPTION

1. Issue a *CLS command.
2. Issue a *RST command.
3. Program the overvoltage protection to maximum to prevent nuisance trips:

`CAL:OUTP:VOLT:PROT:DAC 65535`
4. Program the output voltage to full scale to prevent Constant-Voltage operation:

`CAL:OUTP:VOLT:DAC 65535`
5. Program the output of the first calibration point by sending the following command string from the computer:

`CAL:OUTP:CURR:DAC 3275`
6. Let the output settle and measure the output current with the current shunt and the high precision voltmeter; this is value 1.
7. Enter the actual output current of the first calibration point:

`CAL:OUTP:CURR:FIVEPOINT 1 <value 1>`
8. Program the output of the second calibration point by sending the following command string from the computer:

`CAL:OUTP:CURR:DAC 19000`
9. Let the output settle and measure the output current with the current shunt and the high precision voltmeter; this is value 2.
10. Enter the actual output current of the second calibration point:

`CAL:OUTP:CURR:FIVEPOINT 2 <value 2>`

11. Program the output of the third calibration point by sending the following command string from the computer:

```
CAL:OUTP:CURR:DAC 32000
```
12. Let the output settle and measure the output current with the current shunt and the high precision voltmeter; this is value 3.
13. Enter the actual output current of the third calibration point:

```
CAL:OUTP:CURR:FIVEPOINT 3 <value 3>
```
14. Program the output of the fourth calibration point by sending the following command string from the computer:

```
CAL:OUTP:CURR:DAC 45000
```
15. Let the output settle and measure the output current with the current shunt and the high precision voltmeter; this is value 4.
16. Enter the actual output current of the fourth calibration point:

```
CAL:OUTP:CURR:FIVEPOINT 4 <value 4>
```
17. Program the output of the fifth calibration point by sending the following command string from the computer:

```
CAL:OUTP:CURR:DAC 62250
```
18. Let the output settle and measure the output current with the current shunt and the high precision voltmeter; this is value 5.
19. Enter the actual output current of the fifth calibration point:

```
CAL:OUTP:CURR:FIVEPOINT 5 <value 5>
```
20. To review entered data for five–point current calibration, issue the following query:

```
CAL:OUTP:CURR:FIVEPOINT?
```
21. Program the supply to unlock the non-volatile memory for calibration value storage:

```
CAL:UNLOCK "6867"
```
22. Program the supply to store the calibration values in non-volatile memory:

```
CAL:STORE
```

Allow 15 seconds for the non-volatile memory to be updated with the new calibration values.
23. Program the supply to lock the non-volatile memory for calibration value protection:

```
CAL:LOCK
```

7.7 CURRENT PROGRAMING GAIN/OFFSET AND MEASUREMENT READBACK CALIBRATION (ETHERNET, GPIB)

NOTE: This calibration procedure is required in order to use Constant Power Mode programming.

STEP DESCRIPTION

1. Program the overvoltage protection to maximum to prevent nuisance trips:

`CAL:OUTP:VOLT:PROT:DAC 65535`
2. Program the output voltage to full scale to prevent Constant-Voltage operation:

`CAL:OUTP:VOLT:DAC 65535`
3. Program the output of the first calibration point to approximately 15% of full scale current by sending the following command string from the computer:

`CAL:OUTP:CURR:DAC 9830`
4. Let the output settle and measure the current with the current shunt and the meter.
5. Enter the actual current readback corresponding to the DAC value 9830 of the first calibration point:

`CAL:OUTP:CURR:POINT 1 <current>`
`CAL:MEAS:CURR:POINT 1 <current>`
6. Program the output of the second calibration point to approximately 85% of full scale current by sending the following command string from the computer:

`CAL:OUTP:CURR:DAC 55700`
7. Let the output settle and measure the current with the current shunt and the meter.
8. Enter the actual current readback corresponding to the DAC value 55700 of the second calibration point:

`CAL:OUTP:CURR:POINT 2 <current>`
`CAL:MEAS:CURR:POINT 2 <current>`
9. Reset the output current to 0 amps.

`CAL:OUTP:CURR:DAC 0`

10. Program the Digital Interface Adapter (DIA) to calculate the current readback calibration gain and offset values:

```
CAL:OUTP:CURR:CALC
```

```
CAL:MEAS:CURR:CALC
```

11. Program the DIA to unlock the non-volatile memory for calibration value storage:

```
CAL:UNLOCK "6867"
```

12. Program the Digital Interface Adapter (DIA) to store the date:

GPIB:

```
CAL:DATE YYYYMMDD
```

Ethernet:

```
CAL:MOD:LASTCALDATE MM DD YYYY
```

```
CAL:MOD:NEXTCALDATE MM DD YYYY
```

13. Program the DIA to store the calibration values in non-volatile memory:

```
CAL:STORE
```

Allow 15 seconds for the non-volatile memory to be updated with the new calibration values.

14. Program the DIA to lock the non-volatile memory for calibration value protection

```
CAL:LOCK
```

Calibration is complete.

7.8 ANALOG PROGRAM ADJUSTMENT

This sections applies only to units with the Isolated Interface Adapter *(IIA) option.

All calibration potentiometers can be adjusted through access holes in the top cover of the SGI Series unit. It is **not** necessary to remove the top cover to perform the calibration procedure. Please refer to Figure 7-1 when following the adjustment procedures.

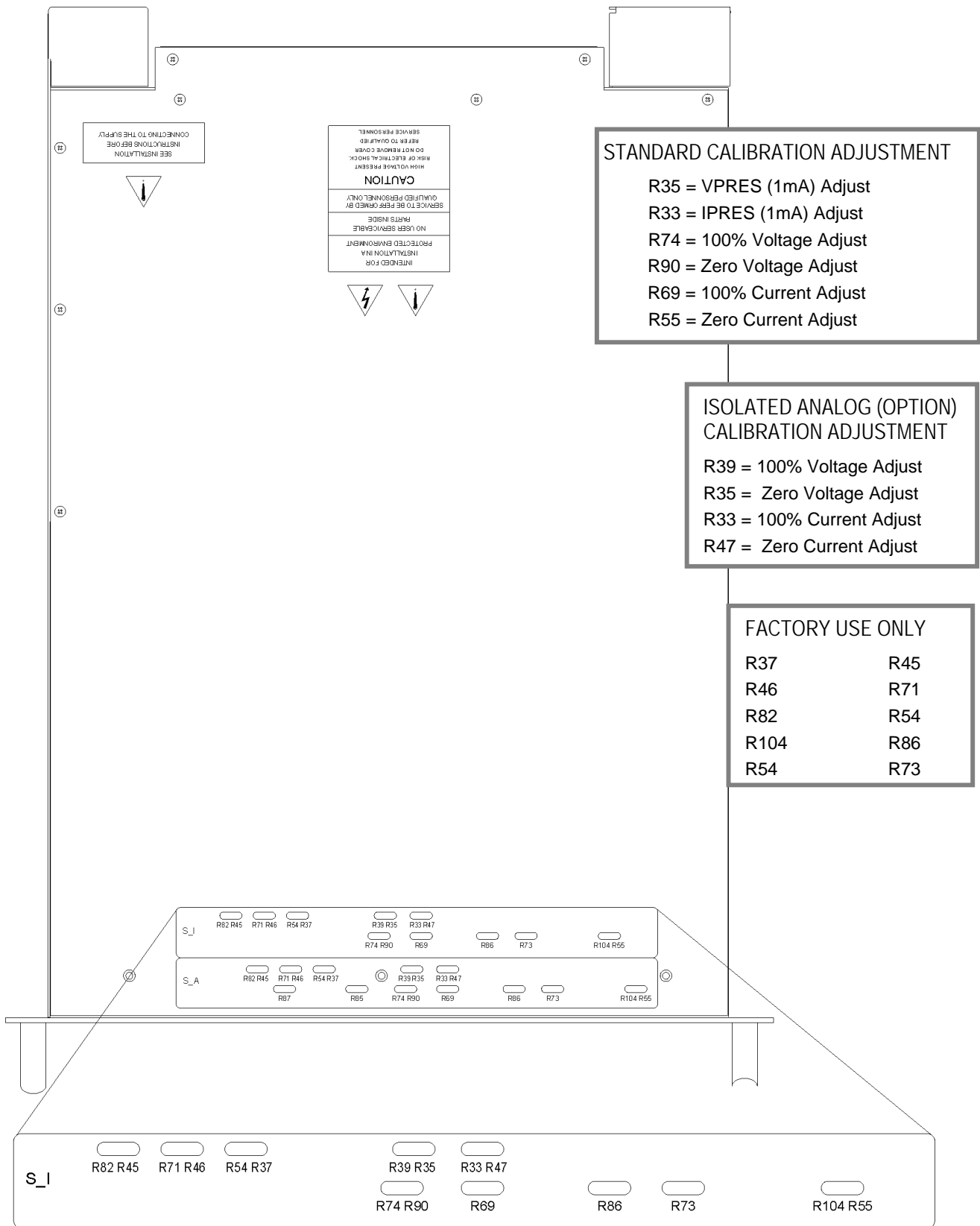

Figure 7-1. Potentiometer Locations

Preparation:

1. Remove prime AC power.
2. Connect the power supply to a precision current shunt (Figure 7-2) capable of a minimum of 10% above full rated output. A fan may be required to cool the shunt.

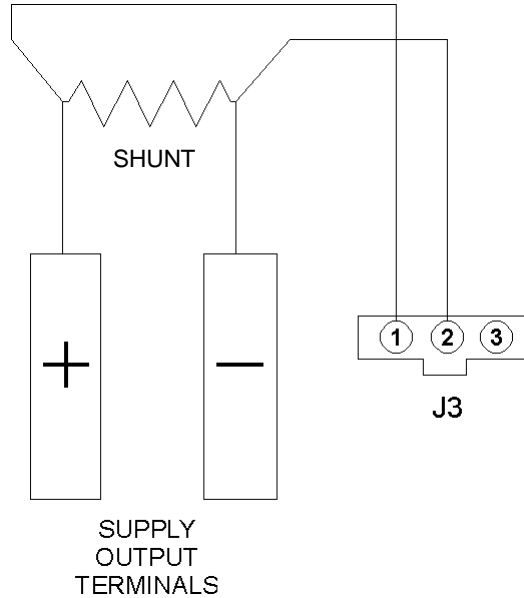

Figure 7-2. Precision Current Shunt

7.8.1 Adjustment for Current Mode

STEP DESCRIPTION

1. Set the SGI Series unit to operate in remote current programming mode using an external 0-5 VDC voltage source as shown in Figure 7-3.

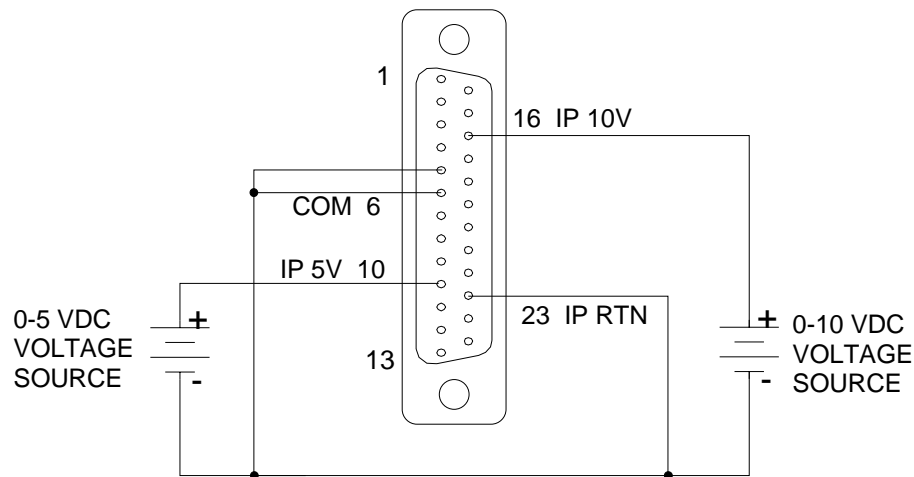

Figure 7-3. Remote Current Programming Using 0-5 VDC or 0-10 VDC Voltage Source

2. Attach a precision meter across the shunt Kelvin terminals.
3. Attach a precision meter in parallel with the voltage programming source.
4. Set the voltage source to 0.0V.
5. Apply AC power and press the "Output On/Off" switch (Figure 7-4) to the ON position.

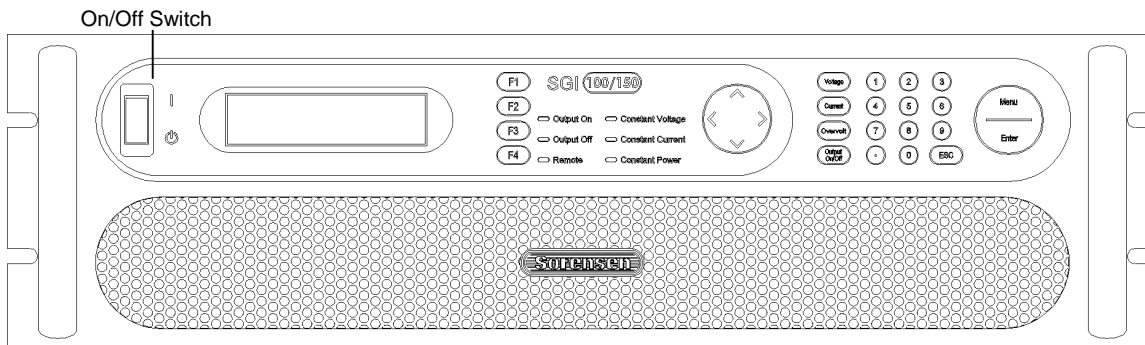

Figure 7-4. SGI Front Panel

6. Set the voltage source to $5.0V \pm 1mV$.
7. Verify the unit is set to $100\% \pm 0.8\%$ of full-scale output current. If necessary, adjust R33 (on the isolated interface adapter) for 100% of full-scale current on the shunt.
8. Set the programming source for $0.5V \pm 1mV$.
9. Verify that the unit is set to $10\% \pm 0.8\%$ of full-scale output current. If necessary, adjust R47 (on the isolated interface adapter) for 10% of full-scale current on the shunt.
10. Repeat the steps above as required to obtain the required accuracy.

7.8.2 Adjustment for Voltage Mode

STEP DESCRIPTION

1. Disable AC power to the unit. Remove the current shunt from the output and verify that there is no load attached.
2. Remove the precision meter leads from the current shunt and apply them across the output terminals.
3. Set the SGI series unit to operate in remote voltage programming mode using an external 0-5 VDC voltage source as shown in Figure 7-5.

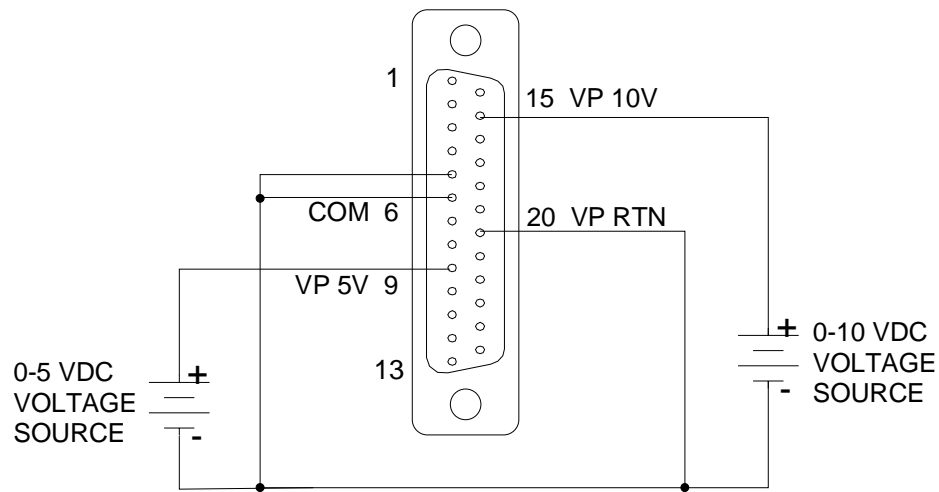

Figure 7-5. Remote Voltage Programming Using 0-5 VDC or 0-10 VDC Voltage Source

4. Apply AC power and press "Output On" switch (Figure 7-4).
5. Set the programming source to $5.0V \pm 1mV$.
6. Verify that the unit is set to $100\% \pm 0.25\%$ of full-scale output voltage. If necessary adjust R39 (on the isolated interface adapter) for 100% output voltage.
7. Set the programming source to $0.5V \pm 1mV$.
8. Verify that the unit is set to $10\% \pm 0.25\%$ of full-scale output voltage. If necessary adjust R35 (on the isolated interface adapter) for 10% output voltage.
9. Repeat the steps above as required to obtain the required accuracy.
10. Remove all connections to the remote analog control connector, J1 (Figure 7-6). Place the jumper between pins 5 and 6. This reverts the SGI series unit back to local, front panel control.

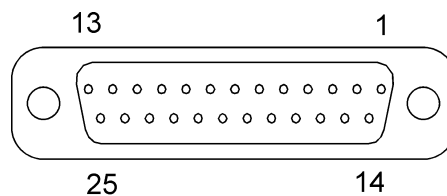

Figure 7-6. Analog Control Connector (J1)

This page intentionally left blank.

SECTION 8
SCPI STATUS IMPLEMENTATION

This page intentionally left blank.

The Protection Enable Register. Readable using the STAT:PROT:ENAB? query command. Write-able using the STAT:PROT:ENAB <value> command. Used to select what fault events may set a bit in the Fault Register. Certain faults can occur even if they are not enabled. This is because the Protection Enable Register merely filters which events are allowed to affect the Fault Register, not whether those events can occur or not. An exception to this rule involves the Constant Voltage Operation, Constant Current Operation, and Foldback Mode Operation bits. If these bits are not enabled, then mode changes shall not cause a shutdown. Read about these bits further in the manual.

Various fault events must be enabled by the protection enable register before they are recorded in the fault register.

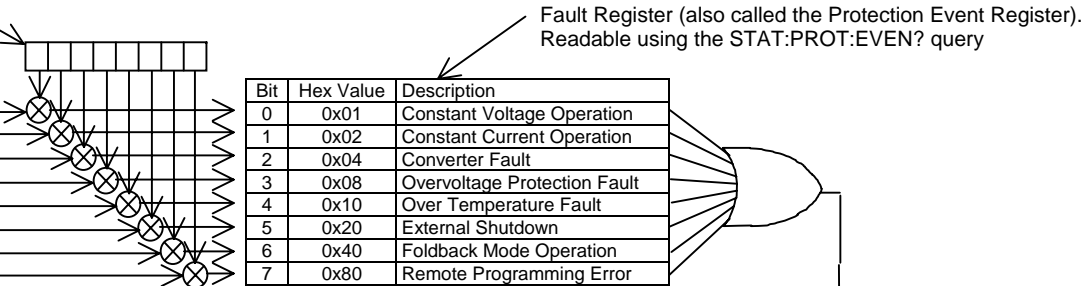

The SESER (Standard Event Status Enable Register). This register is read using the *ESE? SCPI query command. This register is written to using the *ESE <value> command. A "1" in the appropriate bit location enables that corresponding bit from the SESR to pass through to the input of the OR gate to be included in the SESR summary bit (bit 5) in the SCPI Status Byte.

Various events set the SESR bits directly.

Bit	Hex Value	Description
0	0x01	Operation Complete
1	0x02	Request Control (Not Used)
2	0x04	Query Error (Not Used)
3	0x08	Device Dependent Error
4	0x10	Execution Error (e.g., range error)
5	0x20	Command Error (e.g., syntax error)
6	0x40	User Request (Not Used)
7	0x80	Power On

The SESR (Standard Event Service Register). Masking does *not* prevent events from setting bits in the SESR. This facilitates polling as one means of detecting these events since the SESR can be polled (read) using the *ESR? command, irrespective of the bits set or not set in the Standard Event Status Enable Register.

Eight bit wise logical AND operations

The SCPI Status Byte. Read using either the *STB? command, or the GPIB serial poll operation.

Seven bit wise logical AND operations

Bit	Hex Value	Description
0	0x01	Not Used
1	0x02	Protection Event Flag
2	0x04	Error/Event Queue Message Avail.
3	0x08	Questionable Status (Not Used)
4	0x10	Message Available
5	0x20	Standard Event Status Register
6	0x40	RQS/MSS Service Request Bit
7	0x80	Operation Status Flag (Not Used)

The Service Request Enable Register (SRE). Used to enable which Status Byte bits can affect the service request bit. *SRE? reads. *SRE <value> writes.

SCPI STATUS IMPLEMENTATION

This page intentionally left blank.

INDEX

A

- Accuracy
 - programming, Ethernet, 4-4
 - readback, Ethernet, 4-5
- Analog Program Adjustment, 7-11
- Attributes and Functions
 - Ethernet, 4-2

C

- CALibrate, 6-27
- Calibration
 - Current Measurement/Readback
 - Calibration, 7-9
 - Setup for Calibration, 7-2
 - Voltage Programming Calibration, 7-3
 - Warning, 7-1
- Calibration Procedures
 - Current Programming Gain/Offset and Measurement Readback, Ethernet, GPIB, 7-9
 - Introduction, 7-1
 - Voltage Programming, Ethernet, 7-3
- Calibration Procedures, 7-1
 - Analog Program Adjustment, 7-11
 - Current Programming, Ethernet, 7-7
 - Setup, 7-2
 - Voltage Program Gain/Offset and Measurement Readback, Ethernet, GPIB, 7-5

- CALIBRATION SCPI Command Reference, 6-29

- Calibration Procedures
 - Overvoltage Protection Programming
 - Calibration, Ethernet, GPIB, 7-6

- Configuration
 - Ethernet/Lan, 4-3
 - RS232 Setup Procedure, 3-3
 - Setup Procedure, Ethernet, 5-3

- Configurations
 - IEEE 488.2 GPIB Setup Procedures, 3-4
 - Setup Procedure, DHCP, 5-4

- Conventions
 - [], 6-9

E

- Error/Event Queue, 6-5
 - SCPI Error Codes, 6-5
- Ethernet Web Pages, Overview, 5-14
- Examples, Using SCPI Commands, 6-41
 - Hardware Trigger, 6-43
 - OVP Setup, 6-42
 - Power On INIT, 6-45
 - Ramp I, 6-44
 - Ramp V, 6-44
 - Ramp V, 2, 6-45
 - Sequences, 6-46
 - Trigger, 6-43
 - VI Mode, 6-41
- External User Control Signal Connector
 - FAULT output signal, 5-11
 - FOLDBACK output signal, 5-11

ISOLATION output signal, 5-11
 POLARITY output signal, 5-11
 SENSE output signal, 5-11
 SYNC output signal, 5-11
 External User Control Signal Connector
 Warning, 5-12

F

Features
 Ethernet, 4-2
 IEEE 488.2 GPIB/RS232, 2-1
 Functions, 2-2
 IEEE 488.2 GPIB/RS232, Readback, 2-2
 IEEE 488.2/GPIB/RS232, Programmable, 2-1
 Programmable, Ethernet, 4-3
 Readback, Ethernet, 4-3

G

Global Channel 0, 3-8

H

HTRIGGER SCPI Command Reference, 6-25

I

IEEE 488.2 GPIB/RS232 Configurations and
 Remote Programming, 3-1
 IEEE 488.2 GPIB/RS232/Ethernet and SCPI
 Command Operation, 6-1
 IEEE-488.2 Common Command Subsystem,
 6-10
 *CLS, 6-10
 *ESE, 6-10
 *ESR?, 6-10
 *IDN?, 6-10
 *OPC, 6-10
 *RST, 6-11
 *SRE, 6-11
 *STB?, 6-11
 *TST?, 6-11
 *WAI, 6-11

L

Local Operation, 3-6, 5-9

M

MEASURE SCPI Command Reference, 6-17
 MEASURE SCPI Command Subsystem, 6-17

N

Network Setup Procedure
 Auto-IP, 5-5
 DHCP, 5-4
 Serial COM Port, 5-6
 Web Browser, 5-7

O

Operation Status and Questionable Status
 Registers, 6-5
 OUTPUT SCPI Command Reference, 6-18
 OUTPUT SCPI Command Subsystem, 6-18

P

Parameter Definitions, 6-8
 boolean, 6-8
 NR1, 6-8
 NRf, 6-8
 string, 6-9
 Permissions
 Add New User, 5-31
 Edit Existing User, 5-32
 Power-On Conditions
 Default, 5-10
 Default, GPIB, 3-7
 Programming
 accuracy, Ethernet, 4-4
 resolution, Ethernet, 4-4
 Programming Accuracy
 IEEE 488.2 GPIB/RS232, 2-2
 Programming Resolution
 IEEE 488.2 GPIB/RS232, 2-2
 Programming/Communication via Ethernet, 5-
 13
 Raw Socket Interface, 5-13
 Web Server, 5-13
 Protection Event Status Register, 6-3

Q

Queries, 6-9

R

Ramp Function, 6-16

- Ramping
 - Description, 6-16, 6-25
 - Readback
 - accuracy, Ethernet, 4-5
 - resolution, Ethernet, 4-5
 - Readback Accuracy
 - IEEE 488.2 GPIB/RS232, 2-2
 - Readback Resolution
 - IEEE 488.2 GPIB/RS232, 2-2
 - Rear Panel
 - Ethernet Layout, 5-1
 - Rear Panel Configuration Switch
 - Address Selection, GPIB, 3-8
 - GPIB and/or Ethernet, 3-5
 - Power-On GPIB Service Request (PON SRQ) Selection, 3-8
 - Remote/Local Selection, Ethernet, 5-9
 - Remote/Local Selection, GPIB, 3-6
 - Rear Panel Configuration Switch, Ethernet, 5-8
 - Rear Panel Examples, 3-1
 - Remote Operation, 3-6, 5-9
 - Remote Programming via RS-232, 3-9
 - RS-232 Rear Panel RJ-11 Connector Pinout, 3-9
 - Resolution
 - programming, Ethernet, 4-4
 - readback, Ethernet, 4-5
 - Restrictions
 - Sequence Programming, 6-32
- S
- SCPI Command Operation
 - CALibrate, 6-27
 - STATus, 6-19
 - SCPI Command Reference, 6-35
 - SCPI Command Subsystem
 - SGL Program, 6-34
 - SGL Source, 6-33
 - SCPI Commands
 - Application Examples, 6-41
 - CALIBRATION, 6-27
 - HTRIGGER, 6-25
 - Measure, 6-17
 - Output, 6-18
 - SGL Measure, 6-40
 - SGL Trigger, 6-40
 - Source, 6-12
 - Status, 6-19
 - System, 6-21
 - SCPI Conformance
 - Ethernet LXI, VXI-11, 6-8
 - SCPI Conventions, 6-9
 - SCPI Parameter Definitions, 6-8
 - SCPI Status Byte, 6-1
 - SCPI STATUS IMPLEMENTATION, 8-1
 - Sequence Programming
 - Restrictions, 6-32
 - Serial Poll Operation, 6-8
 - Setup Procedure, 5-3
 - Shield Ground, GPIB, 3-8
 - Source SCPI Command Reference, 6-13
 - Specifications
 - IEEE 488.2 GPIB/RS232, 2-2
 - Specifications, Ethernet, 4-3
 - Specifications, GPIB, RS232, 2-2
 - Standard Event Status Register (ESR), 6-3
 - STATUS SCPI Command Reference, 6-20
 - STATUS SCPI Command Subsystem, 6-19
 - Synchronization Pulse, 5-10
 - SYSTEM FAULT REGISTERS, 6-24
 - System Requirements, Ethernet Minimum, 4-1
 - SYSTEM SCPI Command Reference, 6-22
 - SYSTEM SCPI Command Subsystem, 6-21
- T
- TRIGGER SCPI Command Reference, 6-26
 - TRIGGER SCPI Command Subsystem, 6-26
- U
- Units, 6-9
- W
- Web Server
 - Configuration page, 5-17
 - Home page, 5-16
 - Login window, 5-15
 - Security page, 5-30
 - Security page, Add New User, 5-31
 - Security page, Edite Existing User, 5-32
 - Settings page, 5-21
 - SGL Power page, 5-26
 - SGL Presets page, 5-28
 - Status page, 5-24