



ELGAR
ReFlex Power™
Programming Manual

About AMETEK

AMETEK Programmable Power, Inc., a Division of AMETEK, Inc., is a global leader in the design and manufacture of precision, programmable power supplies for R&D, test and measurement, process control, power bus simulation and power conditioning applications across diverse industrial segments. From bench top supplies to rack-mounted industrial power subsystems, AMETEK Programmable Power is the proud manufacturer of Elgar, Sorensen, California Instruments and Power Ten brand power supplies.

AMETEK, Inc. is a leading global manufacturer of electronic instruments and electromechanical devices with annualized sales of \$2.5 billion. The Company has over 11,000 colleagues working at more than 80 manufacturing facilities and more than 80 sales and service centers in the United States and around the world.

Trademarks

AMETEK is a registered trademark of AMETEK, Inc.

Other trademarks, registered trademarks, and product names are the property of their respective owners and are used herein for identification purposes only.

Notice of Copyright

ReFlex Power™ Programming Manual © 2007-2010 AMETEK Programmable Power, Inc. All rights reserved.

Exclusion for Documentation

UNLESS SPECIFICALLY AGREED TO IN WRITING, AMETEK PROGRAMMABLE POWER, INC. ("AMETEK"):

- (a) MAKES NO WARRANTY AS TO THE ACCURACY, SUFFICIENCY OR SUITABILITY OF ANY TECHNICAL OR OTHER INFORMATION PROVIDED IN ITS MANUALS OR OTHER DOCUMENTATION.
- (b) ASSUMES NO RESPONSIBILITY OR LIABILITY FOR LOSSES, DAMAGES, COSTS OR EXPENSES, WHETHER SPECIAL, DIRECT, INDIRECT, CONSEQUENTIAL OR INCIDENTAL, WHICH MIGHT ARISE OUT OF THE USE OF SUCH INFORMATION. THE USE OF ANY SUCH INFORMATION WILL BE ENTIRELY AT THE USER'S RISK, AND
- (c) REMINDS YOU THAT IF THIS MANUAL IS IN ANY LANGUAGE OTHER THAN ENGLISH, ALTHOUGH STEPS HAVE BEEN TAKEN TO MAINTAIN THE ACCURACY OF THE TRANSLATION, THE ACCURACY CANNOT BE GUARANTEED. APPROVED AMETEK CONTENT IS CONTAINED WITH THE ENGLISH LANGUAGE VERSION, WHICH IS POSTED AT WWW.PROGRAMMABLEPOWER.COM.

Date and Revision

February 2010 Revision G

Part Number

M380056-03



Contact Information

Telephone: 800 733 5427 (toll free in North America)
858 450 0085 (direct)
Fax: 858 458 0267
Email: sales@programmablepower.com
service@programmablepower.com
Web: www.programmablepower.com

This page intentionally left blank.

Important Safety Instructions

Before applying power to the system, verify that your product is configured properly for your particular application.

	<p>Hazardous voltages may be present when covers are removed. Qualified personnel must use extreme caution when servicing this equipment. Circuit boards, test points, and output voltages also may be floating above (below) chassis ground.</p>
	<p>The equipment used contains ESD sensitive parts. When installing equipment, follow ESD Safety Procedures. Electrostatic discharges might cause damage to the equipment.</p>

Only *qualified personnel* who deal with attendant hazards in power supplies, are allowed to perform installation and servicing.

Ensure that the AC power line ground is connected properly to the Power Rack input connector or chassis. Similarly, other power ground lines including those to application and maintenance equipment *must* be grounded properly for both personnel and equipment safety.

Always ensure that facility AC input power is de-energized prior to connecting or disconnecting any cable.

In normal operation, the operator does not have access to hazardous voltages within the chassis. However, depending on the user's application configuration, **HIGH VOLTAGES HAZARDOUS TO HUMAN SAFETY** may be normally generated on the output terminals. The customer/user must ensure that the output power lines are labeled properly as to the safety hazards and that any inadvertent contact with hazardous voltages is eliminated.

Guard against risks of electrical shock during open cover checks by not touching any portion of the electrical circuits. Even when power is off, capacitors may retain an electrical charge. Use safety glasses during open cover checks to avoid personal injury by any sudden component failure.

Neither AMETEK Programmable Power Inc., San Diego, California, USA, nor any of the subsidiary sales organizations can accept any responsibility for personnel, material or inconsequential injury, loss or damage that results from improper use of the equipment and accessories.

SAFETY SYMBOLS

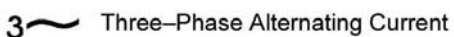
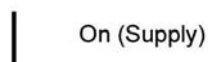
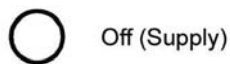
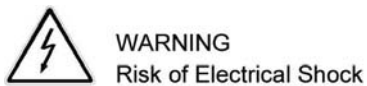

This page intentionally left blank.

Product Family: ReFlex Power™

Warranty Period: One Year

WARRANTY TERMS

AMETEK Programmable Power, Inc. ("AMETEK"), provides this written warranty covering the Product stated above, and if the Buyer discovers and notifies AMETEK in writing of any defect in material or workmanship within the applicable warranty period stated above, then AMETEK may, at its option: repair or replace the Product; or issue a credit note for the defective Product; or provide the Buyer with replacement parts for the Product.

The Buyer will, at its expense, return the defective Product or parts thereof to AMETEK in accordance with the return procedure specified below. AMETEK will, at its expense, deliver the repaired or replaced Product or parts to the Buyer. Any warranty of AMETEK will not apply if the Buyer is in default under the Purchase Order Agreement or where the Product or any part thereof:

- is damaged by misuse, accident, negligence or failure to maintain the same as specified or required by AMETEK;
- is damaged by modifications, alterations or attachments thereto which are not authorized by AMETEK;
- is installed or operated contrary to the instructions of AMETEK;
- is opened, modified or disassembled in any way without AMETEK's consent; or
- is used in combination with items, articles or materials not authorized by AMETEK.

The Buyer may not assert any claim that the Products are not in conformity with any warranty until the Buyer has made all payments to AMETEK provided for in the Purchase Order Agreement.

PRODUCT RETURN PROCEDURE

1. Request a Return Material Authorization (RMA) number from the repair facility (**must be done in the country in which it was purchased**):
 - **In the USA**, contact the AMETEK Repair Department prior to the return of the product to AMETEK for repair:
Telephone: 800-733-5427, ext. 2295 or ext. 2463 (toll free North America)
858-450-0085, ext. 2295 or ext. 2463 (direct)
 - **Outside the United States**, contact the nearest Authorized Service Center (ASC). A full listing can be found either through your local distributor or our website, www.programmablepower.com, by clicking Support and going to the Service Centers tab.
2. When requesting an RMA, have the following information ready:
 - Model number
 - Serial number
 - Description of the problem

NOTE: Unauthorized returns will not be accepted and will be returned at the shipper's expense.

NOTE: A returned product found upon inspection by AMETEK, to be in specification is subject to an evaluation fee and applicable freight charges.

This page intentionally left blank.

CONTENTS

SECTION 1 REMOTE PROGRAMMING OVERVIEW	15
1.1 System Level Introduction	15
1.2 Features and Functions	15
1.3 ReFlex Power™ IVI-COM drivers.....	16
1.3.1 IVI-COM Drivers Installation	16
1.3.2 IVI-COM Drivers Help	16
1.4 ReFlex Power™ FIRMWARE COMPATIBILITY.....	17
SECTION 2 CONTROLLER MODULE REMOTE PROGRAMMING ...	18
2.1 Introduction	18
2.2 Features and Functions	18
2.3 Power-On Conditions and Address Configuration.....	19
2.4 Ethernet Configuration and Remote Programming	19
2.4.1 Ethernet Connection Requirements.....	19
2.4.2 Ethernet Setup Procedure	20
2.4.3 Launching Ethernet Communication.....	21
2.5 ReFlex Power™ Ethernet Interface	23
2.5.1 Home Page	23
2.5.2 LOGIN Screen	24
2.5.3 IP Configuration	25
2.5.4 Security Page.....	28
2.5.5 Modules Page	31
2.6 Launching Control Communication	32
2.6.1 Module Location Identification (Address).....	34
2.6.2 Communication with the System	35

2.7	SCPI Command Operation	35
2.7.1	Error/Event Queue	35
2.8	LXI™ and SCPI Conformance Information.....	36
2.8.1	Parameter Definitions	37
2.8.2	Numeric Data Dimensional Units.....	37
2.8.3	Conventions	37
2.8.4	Query Syntax	38
2.9	Common SCPI Commands	39
2.10	EIB SCPI Commands	40
2.10.1	EIB SCPI Command Summary.....	40
2.10.2	EIB SCPI Command Reference	40
2.11	SYSTEM:NETWORK SCPI Commands.....	40
2.11.1	SYSTEM:NETWORK SCPI Command Summary	40
2.11.2	SYSTEM:NETWORK SCPI Command Reference	41
2.13	RFP Service Request	43
2.13.1	Background	43
2.13.2	Theory of Operation	43
2.13.3	Event Status Register	43
2.13.4	Protection Event Register	44
2.13.5	Register Allocation	44
2.13.6	Execution time Operation.....	44
2.13.7	SRQ related SCPI Commands	45
2.13.8	Setting the SRQ bit in the STB, an example.....	47
2.14	Trigger SCPI Commands	48
2.14.1	TRIGGER SCPI Command Summary.....	48
2.14.2	TRIGGER SCPI Command Reference.....	48
SECTION 3 DC MODULE REMOTE PROGRAMMING		50
3.1	Introduction	50
3.2	Features and Functions	50
3.3	Power-On Conditions.....	51
3.4	Error Codes	51
3.4.1	Error/Event Queue	51
3.5	Common SCPI Commands	53

3.6	CALIBRATION SCPI Commands	54
3.6.1	CALIBRATION SCPI Command Summary	54
3.6.2	CALIBRATION SCPI Command Reference	55
3.7	MEASURE SCPI Commands	56
3.7.1	MEASURE SCPI Command Summary.....	56
3.7.2	MEASURE SCPI Command Reference	56
3.8	OUTPUT SCPI Commands	57
3.8.1	OUTPUT SCPI Command Summary.....	57
3.8.2	OUTPUT SCPI Command Reference	57
3.9	SOURCE SCPI Commands	59
3.9.1	SOURCE SCPI Command Summary	59
3.9.2	SOURCE SCPI Command Reference.....	59
3.10	INPUT SCPI Commands	60
3.10.1	INPUT SCPI Command Summary.....	60
3.10.2	INPUT SCPI Command Reference	60
3.11	STATUS SCPI Commands.....	61
3.11.1	STATUS SCPI Command Summary	61
3.11.2	STATUS SCPI Command Reference	61
3.12	Trigger SCPI Commands and Lists	62
3.12.1	LIST and Trigger Command Operation	62
3.13	Software Triggered Setpoints and Ramps.....	74
3.13.1	Volt and Current Software Setpoints Command summary.....	74
3.13.2	Voltage and Current Software Ramps Command Summary.....	75
3.14	TRIGGER SCPI Commands	77
3.14.1	TRIGGER SCPI Command Summary.....	77
3.14.2	Trigger SCPI Command Reference.....	77
3.15	LIST SCPI Commands	79
3.15.1	LIST SCPI Command Summary.....	79
3.15.2	LIST SCPI Command Reference.....	79
3.16	DC SYSTEM SCPI Commands.....	82
3.16.1	DC SYSTEM SCPI Command Summary	82
3.16.2	SYSTEM SCPI Command Reference	82
3.17	Examples of Using the SCPI Commands.....	83

SECTION 4 AC MODULE REMOTE PROGRAMMING	86
4.1 Introduction	86
4.2 Features and Functions	86
4.3 Power-On Conditions.....	87
4.4 Error Codes	88
4.4.1 SCPI Error Codes	88
4.4.2 Error/Event Queue	89
4.5 Common SCPI Commands	90
4.6 CALIBRATION SCPI Commands	91
4.6.1 CALIBRATION SCPI Command Summary	91
4.6.2 CALIBRATION SCPI Command Reference	93
4.7 MEASURE SCPI Commands	96
4.7.1 MEASURE SCPI Command Summary.....	96
4.7.2 MEASURE SCPI Command Reference	96
4.8 OUTPUT SCPI Commands	97
4.8.1 OUTPUT SCPI Command Summary.....	97
4.8.2 OUTPUT SCPI Command Reference	97
4.9 SOURCE SCPI Commands	98
4.9.1 SOURCE SCPI Command Summary	98
4.9.2 SOURCE SCPI Command Reference.....	99
4.10 STATUS SCPI Commands.....	103
4.10.1 STATUS SCPI Command Summary	103
4.10.2 STATUS SCPI Command Reference	103
4.11 SYSTEM SCPI Commands	105
4.11.1 SYSTEM SCPI Command Summary.....	105
4.11.2 SYSTEM SCPI Command Reference	105
4.12 EXAMPLE SCPI COMMANDS to set phase and parallel groups	105
4.12.1 Examples Creating a Phase Group	105
4.12.2 Example creating a Parallel Group	106
 SECTION 5 LOAD MODULE REMOTE PROGRAMMING	 108
5.1 Introduction	108
5.2 Features and Functions	108

5.3	Power-On Conditions.....	109
5.4	Error Codes	110
5.4.1	SCPI Error Codes	110
5.4.2	Error/Event Queue	110
5.5	Common SCPI Commands	111
5.6	Calibration SCPI Commands.....	112
5.6.1	CALIBRATION SCPI Command Summary	112
5.6.2	CALIBRATION SCPI Command Reference	113
5.7	MEASURE SCPI Commands	114
5.7.1	MEASURE SCPI Commands Summary.....	114
5.7.2	MEASURE Commands Reference	114
5.8	INPUT SCPI Commands	115
5.8.1	INPUT SCPI Command Summary.....	115
5.8.2	INPUT SCPI Command Reference	115
5.9	SOURCE SCPI Commands	116
5.9.1	SOURCE SCPI Command Summary	116
5.9.2	SOURCE SCPI Command Reference.....	116
5.10	STATUS SCPI Commands.....	117
5.10.1	STATUS SCPI Command Summary	117
5.10.2	STATUS SCPI Command Reference	117
5.11	SYSTEM SCPI Commands	119
5.11.1	SYSTEM SCPI Command Summary.....	119
5.11.2	SYSTEM SCPI Command Reference	119
SECTION 6 FIXED POWER DC REMOTE PROGRAMMING.....		121
6.1	Introduction	121
6.2	Features and Functions	121
6.2.2	Power-On Conditions.....	122
6.3	Error Codes	122
6.3.1	SCPI Error Codes	122
6.3.2	Error/Event Queue	123
6.4	Common SCPI Commands	123
6.5	CALIBRATION SCPI Commands.....	124
6.5.1	CALIBRATION SCPI Command Summary	125

6.5.2	CALIBRATION SCPI Command Reference	125
6.6	OUTPUT SCPI Commands	126
6.6.1	OUTPUT SCPI Command Summary.....	126
6.6.2	OUTPUT SCPI Command Reference	126
6.7	STATUS Commands	126
6.7.1	STATUS SCPI Command Summary	126
6.7.2	STATUS SCPI Command Reference	126
6.8	SYSTEM Commands.....	127
6.8.1	SYSTEM SCPI Command Summary.....	127
6.8.2	SYSTEM SCPI Command Reference	127

LIST OF TABLES

- Table 2-1. Remote Power-On Conditions 19
- Table 2-2. SCPI Error Codes 36
- Table 2-3. Parameter Definitions 37
- Table 2-4. Numeric Data Units 37
- Table 2-5. Common SCPI Commands..... 39
- Table 2-6. Module *TST? Error Response Bits..... 39
- Table 3-1. Remote Power-on Conditions 51
- Table 3-2. Common SCPI Commands..... 53
- Table 3-3. Fault and Enable Register 61
- Table 3-4. SCPI for Module Trigger Routing..... 66
- Table 3-5. Input Trigger Signal Specifications 67
- Table 3-6. Output Trigger Specifications..... 68
- Table 3-7. Group Pulse Function 72
- Table 3-8. Software Triggered Setpoints 75
- Table 3-9. Software Ramps..... 76
- Table 4-1. Remote Power-On Conditions 87
- Table 4-2. AC Enable Register 0 104
- Table 4-3. AC Enable Register 1 104
- Table 5-1. Load Power-on Conditions..... 109
- Table 5-2. Enable Register..... 118
- Table 6-1. Remote Power-on Conditions 122
- Table 6-2. Faults / Enable Register..... 127

LIST OF FIGURES

Figure 2-1. Ethernet Network Connection.....20

Figure 2-2. Ethernet Direct Connection.....21

Figure 2-3. LXI Discovery Browser Window.....22

Figure 2-4. ReFlex Power™ Ethernet Interface Home Page.....23

Figure 2-5. LOGIN Page with Authorization warning24

Figure 2-6. IP CONFIGURATION Page, Default25

Figure 2-7. IP CONFIGURATION Static IP selected, but not yet applied.....26

Figure 2-8. IP CONFIGURATION Page with Error Message for invalid IP Address27

Figure 2-9. Security Page.....28

Figure 2-10. Security: Add New User.....29

Figure 2-11. Security: Edit Existing User30

Figure 2-12. MODULES Page Showing Installed Power Modules31

Figure 2-13. Net Test Window32

Figure 2-14. Query IP Address Example33

Figure 2-15. Address Location and Chassis Configuration.....34

Figure 2-16. Photo of Multi-Chassis ReFlex Power™ System34

Figure 3-1. RFP Trigger Logic.....63

Figure 3-2. Fixed Mode Trigger Input.....64

Figure 3-3. Module/Buss Trigger Input.....65

Figure 3-4. Module/Buss Trigger Out.....65

Figure 3-5. Trigger Signal Types.....67

Figure 3-6. Output Trigger Timing.....68

Figure 3-7. Trigger Input Responses69

Figure 3-8. List Mode Logic.....70

Figure 3-9. Group Pulse Sequence.....72

SECTION 1

REMOTE PROGRAMMING

OVERVIEW

1.1 SYSTEM LEVEL INTRODUCTION

This manual covers remote programming of the ReFlex Power™ system and should be used in conjunction with the ReFlex Power™ Operation Manual, M380056-01. This remote programming interface enables system operation from a computer via Ethernet, allowing full remote programming control and monitoring of all system modules, which include five basic types: the ReFlex Power™ Controller (RFPC), AC, DC, Active Load (AL) and Fixed Power modules. This programming manual is divided among sections addressing each module type, beginning with the RFPC and its set up and connection instructions for Ethernet control via SCPI commands. Set up includes installing IVI-COM driver files, connecting the control computer with the RFPC, and launching Ethernet and control communications. The remaining module types are addressed in subsequent sections, each with their applicable SCPI commands.



WARNING

Avoid personal injury or damage to any part of the system, observe all electrical safety precautions described in the ReFlex Power™ operation manuals when operating a ReFlex Power™ system. When developing a program to control a ReFlex Power™ system, strictly adhere to connections instructions and avoid contact with the power module outputs.

1.2 FEATURES AND FUNCTIONS

Features and functions are as follows:

- SCPI compliant command set
- Field-upgradeable firmware for all modules via Ethernet
- System extensible up to eight Mainframes and ninety-six modules
- Configuration flexibility

1.3 REFLEX POWER™ IVI-COM DRIVERS

This programming manual was not written for users who will develop applications using the ReFlex Power™ IVI-COM (Interchangeable Virtual Instrument Component Object Model) drivers. However, it is a good supplement to help the developer understand the exact behavior of the hardware in response to the individual SCPI commands produced by the drivers.

The ReFlex Power™ IVI-COM drivers allow users to develop applications in Windows to control a ReFlex Power™ system in several programming languages and environments, including C++, VB 6.0, VB.Net, C# or Lab VIEW. The drivers also include an IVI-C wrapper for use with LabWindows or the C programming language.

1.3.1 IVI-COM DRIVERS INSTALLATION

There are three ReFlex Power™ IVI-COM drivers for the ReFlex Power™ system, one each for DC, AC and Loads. They are available as three separate Windows .msi installation files on the CD-ROM (M380399-01) supplied with the unit, and must be installed in the following sequence:

1. Install the IVI Foundations shared components (must be accomplished first in order to successfully install the ReFlex Power™ IVI-COM drivers). You may either click the **IVI Shared Components** link at the bottom of the Downloads page at http://www.programmablepower.com/go/rfp_downloads, or go directly to http://www.ivifoundation.org/shared_components/Default.aspx, and choose between the .msi file or .exe file.
2. Install a VISA (Virtual Instrument Software Architecture) layer such as NI-VISA. Again, either click the **VISA RTE** link also at the bottom of the Downloads page, or go directly to <http://www.ni.com/support/visa/>.
3. Install the applicable driver files (AC, DC, Loads) located in the RFP_IVI-COM Drivers folder on the CD-ROM.

1.3.2 IVI-COM DRIVERS HELP

The three IVI-COM drivers include extensive help files and sample applications. Once installation is complete, the help files and readme.txt will be available on your Start menu.

If you are not already familiar with IVI-COM drivers, it is strongly recommended that you read the entire “Getting Started with the IVI-COM Driver” section of the help files. This should answer all questions about installation, compliance, configuration, and development with IVI-COM. It also references several other good sources for information on IVI-COM

development such as the IVI Foundation, National Instruments, and Pacific MindWorks Web sites.

1.4 REFLEX POWER™ FIRMWARE COMPATIBILITY

With the release of firmware version 3.000.000 and higher, the controller firmware revision and the firmware in the power and load modules must be at the same major revision level. Thus, it is not possible to mix revision 2.000.000 and revision 3.000.000 assets. When powering up a system with mixed revision assets installed, the red Fault LED will blink on a version 3 controller if a version 2 module is detected. If a version 3 Module detects a version 2 controller, the Module's red Fault LED will blink indicating the firmware miss-match. The *TST? response will also have an error bit set indicating miss-matched firmware.

RFP version 2 Modules can be upgraded to version 3, and version 3 modules can be downgraded to version 2.

The Order numbers for version 2 and version 3 Modules are different, contact Sales for further information.

SECTION 2

CONTROLLER MODULE REMOTE PROGRAMMING

2.1 INTRODUCTION

This section covers the set up and remote programming of the ReFlex Power™ system Controller (RFPC). All SCPI commands for the ReFlex Power™ system will pass through the RFPC, which validates the command syntax and confirms that the target module(s) exist, before sending the command through. While most commands are intended for specific modules or module groups, some commands will affect the entire system, and others will return information from the RFPC.

The syntax of all SCPI commands implemented by the ReFlex Power™ system and documented in this manual, are either SCPI confirmed in the SCPI 1999.0 Specification, Volume 2: Command Reference, or they are customized commands not part of the SCPI definition but conform to SCPI syntax.

The design of the RFP System is based on a loosely coupled, multi-user, multi-processor, pre-emptive multitasking, and multi-threaded control system, composed of semi-autonomous modules. This allows multiple users to control various parts of the RFP system independently from each other. User coordination is required.

2.2 FEATURES AND FUNCTIONS

FEATURES

- SCPI compliant command set
- Field-upgradeable firmware via Ethernet
- Support for 96 modules

READBACK FUNCTIONS

- Status and Accumulated Status registers
- Programming error codes
- Fault codes

- Manufacturer, power supply model, serial number, and firmware version identification

2.3 POWER-ON CONDITIONS AND ADDRESS CONFIGURATION

Table 2-1 presents remote power-on conditions for the ReFlex Power™ Controller (RFPC).

Table 2-1. Remote Power-On Conditions

Condition	Default
Service Request Capability	Off, can be enabled by command and IVI Driver configuration.

2.4 ETHERNET CONFIGURATION AND REMOTE PROGRAMMING

Operating the ReFlex Power™ system via the Controller module requires a computer with an Ethernet LAN connection. The Controller communication interface conforms to IEEE 802.3, commonly known as Ethernet 10 Base-T and 100 Base-T, and is **LXI**™ (LAN eXtensions for Instrumentation) class C compliant.

After installing the IVI-COM drivers (Section 1.3.1), begin the Ethernet connection and setup for communication.

2.4.1 ETHERNET CONNECTION REQUIREMENTS

For Ethernet connection between the ReFlex Power™ Controller module and the control computer, you will need:

- **EnetTest.exe** file located in the *RFP Download* folder on the ReFlex Power™ CD-ROM (P/N M380399-01) supplied with your product
- **LXI_Browser_setup.exe** file (if you don't know the IP address of the Controller module), which is also located in the *RFP Download* folder
- **RJ45-type connectors** with Category 5 or 5e (Cat 5) cables:
 - For a **network** connection, via local router, switch or hub, to isolate the local nodes and segments from the rest of the network, use two straight-through cables.
 - For a **direct** connection, if the control computer's Ethernet interface does not support Auto-MDIX, use a crossover cable to connect the control computer directly to the Controller module via their respective Net/LAN connectors.
- **Jumper plug** to enable voltage output of each module as follows:

- For the ReFlex Power™ **Controller module**, you will need either Loop-back Connector Assembly 5380509-01 or Cable Assembly 5380441-01 or -03.
- For all **other modules** (power supplies and loads), you will need either Loop-back Connector Assembly 5380508-01 or Cable Assembly 5380443-01 or-03.

2.4.2 ETHERNET SETUP PROCEDURE

The ReFlex Power™ Quick Reference Guide (M380056-04) is a condensed version of this procedure for Ethernet setup.

1. With all power disabled, assemble your ReFlex Power™ system and main power connections according to the ReFlex Power™ Operation Manual, M380056-01.
2. Disable the Remote Inhibit of the Controller module, by connecting their discrete signals with a jumper plug that connects Pins 1 and 9 on the front panel interface connector, using either Loop-back Connector Assembly 5380509-01 or Cable Assembly 5380441-01 or -03.
3. Enable the voltage output of all other power supply and/or load modules by connecting their discrete signals with a jumper plug that connects Pins 1 and 6 on the front panel interface connector of each module, using either Loop-back Connector Assembly 5380508-01 or Cable Assembly 5380443-01 or-03.
4. Create either a Network or direct connection between the control computer and the ReFlex Power™ system, using Category 5 or 5e (Cat 5) cables with RJ45-type connectors, as follows:

Ethernet Network Connection

A Network connection via local router, or switch isolates the local nodes and segments from the rest of the Network, a hub does not. Use two straight through cables to connect the control computer and the ReFlex Power™ Controller from their respective Net/LAN connectors, to a local router, switch or hub (Figure 2-1). ReFlex Power™ Controller will DHCP if available from the network.

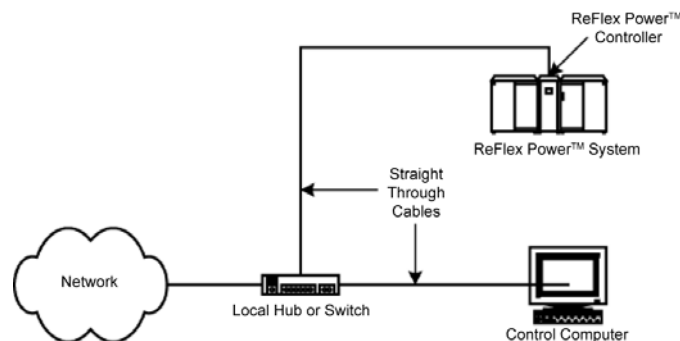

Figure 2-1. Ethernet Network Connection

Direct Connection

If the control computer's Ethernet interface does not support Auto-MDIX, use a crossover cable to connect the control computer directly to the Controller module between their respective Net/LAN connectors (Figure 2-2). The factory default ReFlex Power™ Controller settings will select an AutoIP address, it will be in the 169.254.1-254.NNN range, if DHCP is not available, check the Control computer for proper settings.

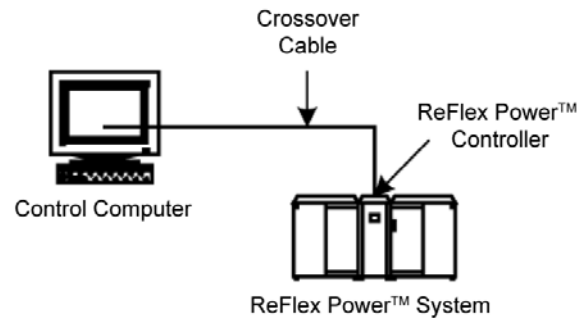

Figure 2-2. Ethernet Direct Connection

5. Press the POWER switch on the Controller's front panel to power on the system. Allow time for the system to boot.
6. Launch the Ethernet connection (Section 2.4.3), or go straight to the Net Test window to begin control communication (Section 2.6).

2.4.3 LAUNCHING ETHERNET COMMUNICATION

Once the Ethernet connection is made and the system is powered on, the Controller module's LEDs, LAN and Con, are lit, and Net is lit during network traffic.

When there is no Network traffic, the Net LED is not lit.

If the Con LED is not lit, the RFPC is not connected to a functioning network.

If the Lan LED is not lit, the RFPC has detected that it cannot retrieve an IP address via DHCP, or if configured for a fixed IP address, the requested IP address is already in use.

Execute the LXI™_Browser_setup file located in the ReFlex Power executables folder on the ReFlex Power™ CD-ROM, M380399-01. This will bring up the LXI™ Discovery Browser interface (Figure 2-3), which will find and display the IP address of the ReFlex Power™ Controller module.

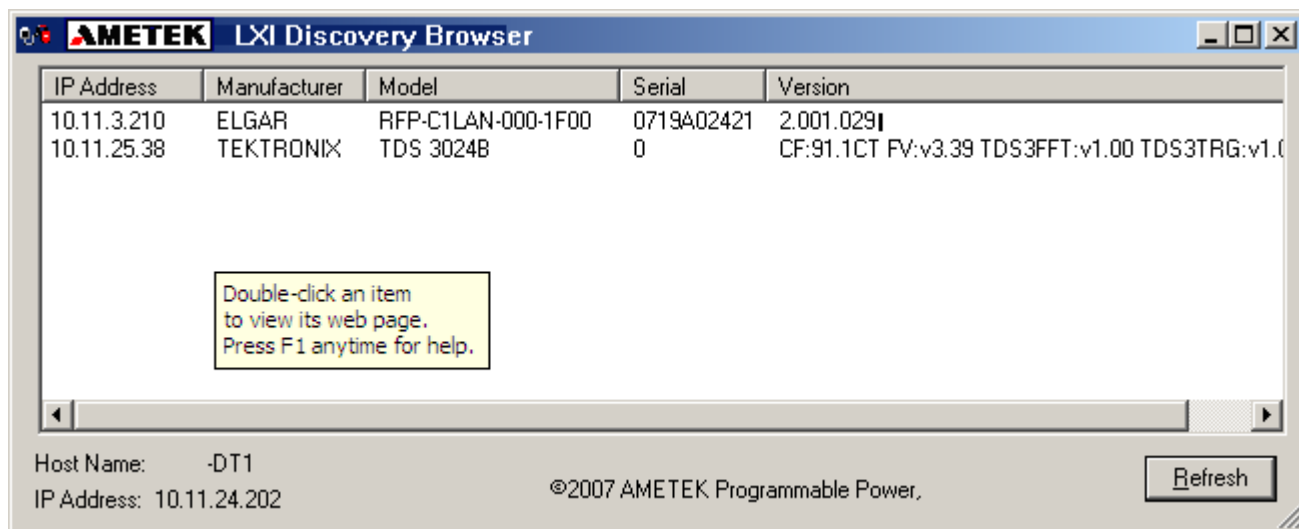

Figure 2-3. LXI Discovery Browser Window

2.5 REFLEX POWER™ ETHERNET INTERFACE

To bring up the ReFlex Power™ Ethernet Interface, in the LXI™ Discovery Browser, double click the IP address of the Controller module. This brings up that Controller module's HOME page (Figure 2-4).

2.5.1 HOME PAGE

The ReFlex Power™ Ethernet interface HOME page displays the current information about the specific Controller module that you are connected to.

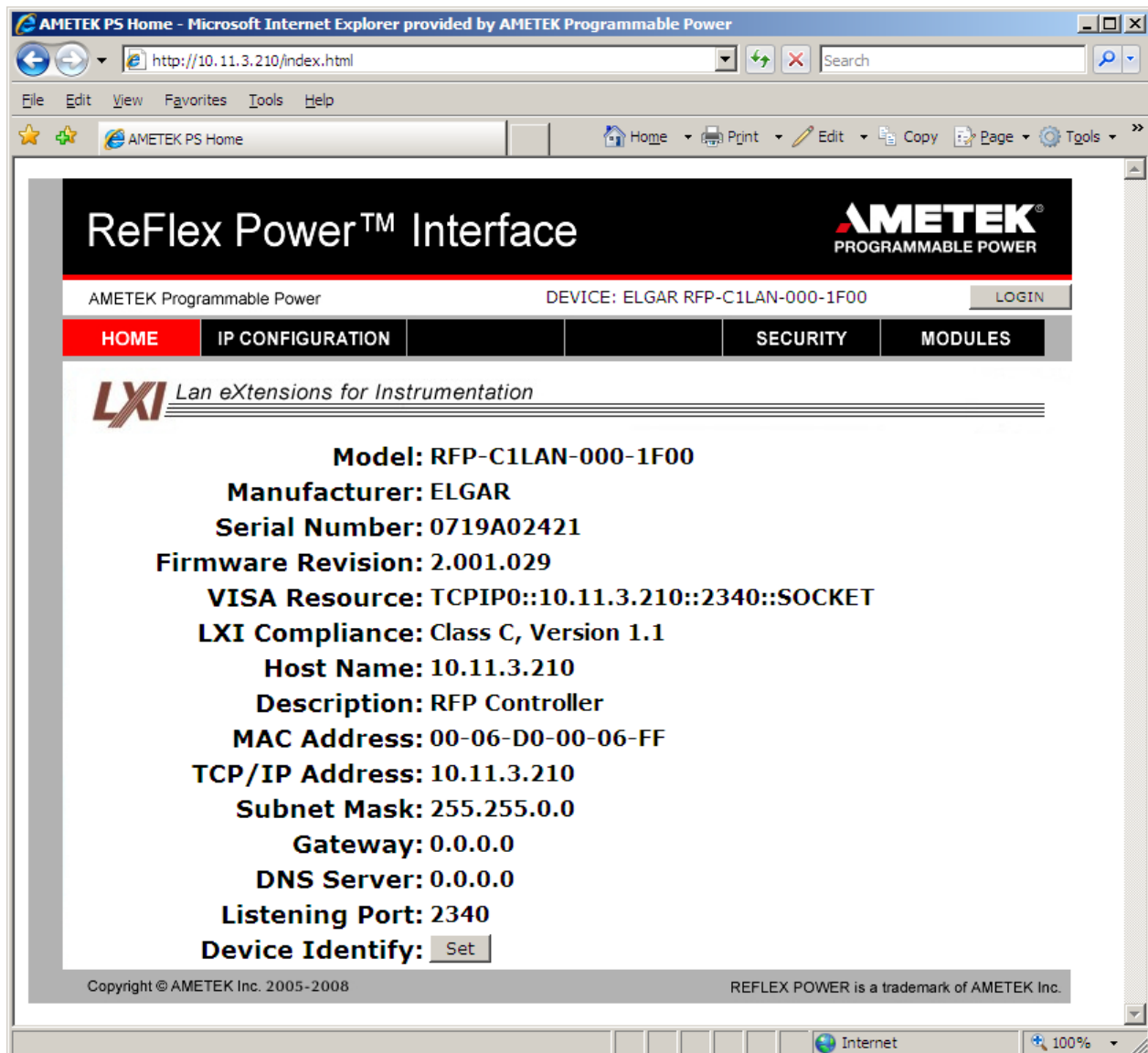

Figure 2-4. ReFlex Power™ Ethernet Interface Home Page

If you are not sure you are connected to the correct Controller module, e.g., multiple Controller modules were listed in the LXI™ Discovery Browser, click the SET button at the bottom of the HOME page (when clicked, the SET button becomes the CLEAR button). SET causes that Controller module's LAN LED to blink for identification purposes. Click the CLEAR button to stop the blinking (CLEAR button changes back to SET).

The HOME page has links (tabs) to three other pages in the ReFlex Power™ Interface: IP CONFIGURATION, SECURITY and MODULES. Also, in the upper right area of the interface is the LOGIN button.

2.5.2 LOGIN SCREEN

Click the LOGIN button to log in; clicking the IP CONFIGURATION tab also brings up the LOGIN page, but with an error message prompting you to log in (Figure 2-5).

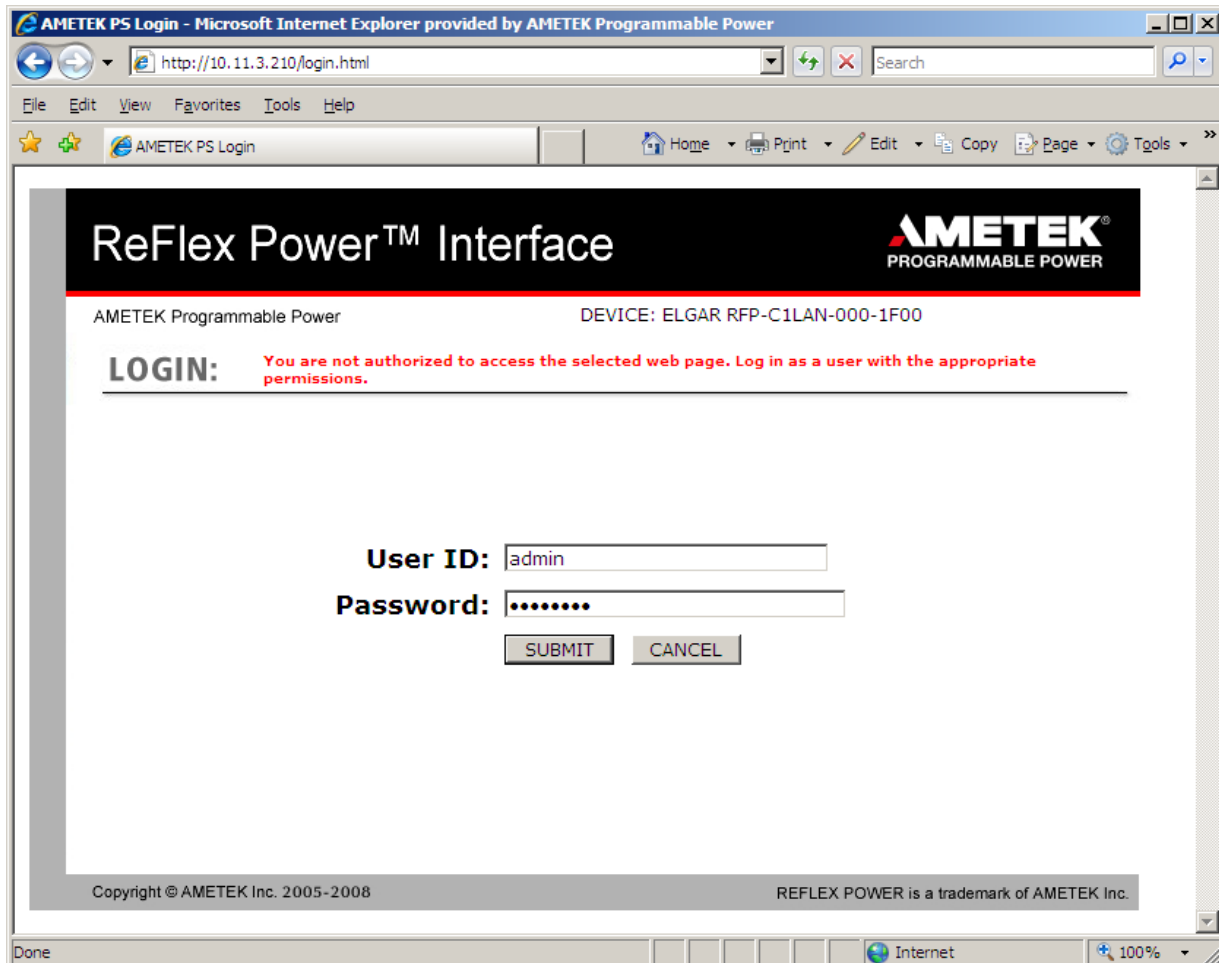

Figure 2-5. LOGIN Page with Authorization warning

With authorized log-in (default parameters: User ID = **admin**; Password = **password**), click the IP CONFIGURATION tab (Figure 2-6) where you can customize the Host Name and Description, and/or select *Use a Static IP Address* (Figure 2-7) to change IP Address, Subnet Mask, Gateway, DNS Server and Listening Port. Please ask your IT Administrator for support.

2.5.3 IP CONFIGURATION

The default IP Address configuration is DHCP-enabled and Auto IP-enabled. If a DHCP server is not found, an address in the range of **169.254.[1 thru 254].[0 thru 255]** will be selected. If there is no DHCP server on your local network, your PC must also be configured for Auto-IP for the RFP system to be discovered. For *only* DHCP, select “Obtain an IP Address Automatically” and deselect “Auto IP Enabled”). Click the APPLY button to set your inputs.

The screenshot shows the 'ReFlex Power™ Interface' web page. The browser title is 'AMETEK PS Configuration - Microsoft Internet Explorer provided by AMETEK Programmable Power'. The address bar shows 'http://10.11.20.11/config.html'. The page header includes the AMETEK logo and 'PROGRAMMABLE POWER'. Below the header, it says 'AMETEK Programmable Power' and 'DEVICE: ELGAR RFP-C1LAN-000-1F00' with a 'LOGOUT' button. A navigation bar has 'HOME', 'IP CONFIGURATION' (highlighted), 'SECURITY', and 'MODULES'. The main content area is titled 'IP CONFIGURATION:' and features the LXI logo. The configuration fields are as follows:

- Host Name:
- Description:
- TCP/IP Configuration:
 - Use a Static IP Address
 - Obtain an IP Address Automatically
 - Auto IP Enabled
- IP Address:
- Subnet Mask:
- Gateway:
- DNS Server:
- Listening Port:

An 'APPLY' button is located at the bottom of the form. The footer contains 'Copyright © AMETEK Inc. 2005-2008' and 'REFLEX POWER is a trademark of AMETEK Inc.'

Figure 2-6. IP CONFIGURATION Page, Default

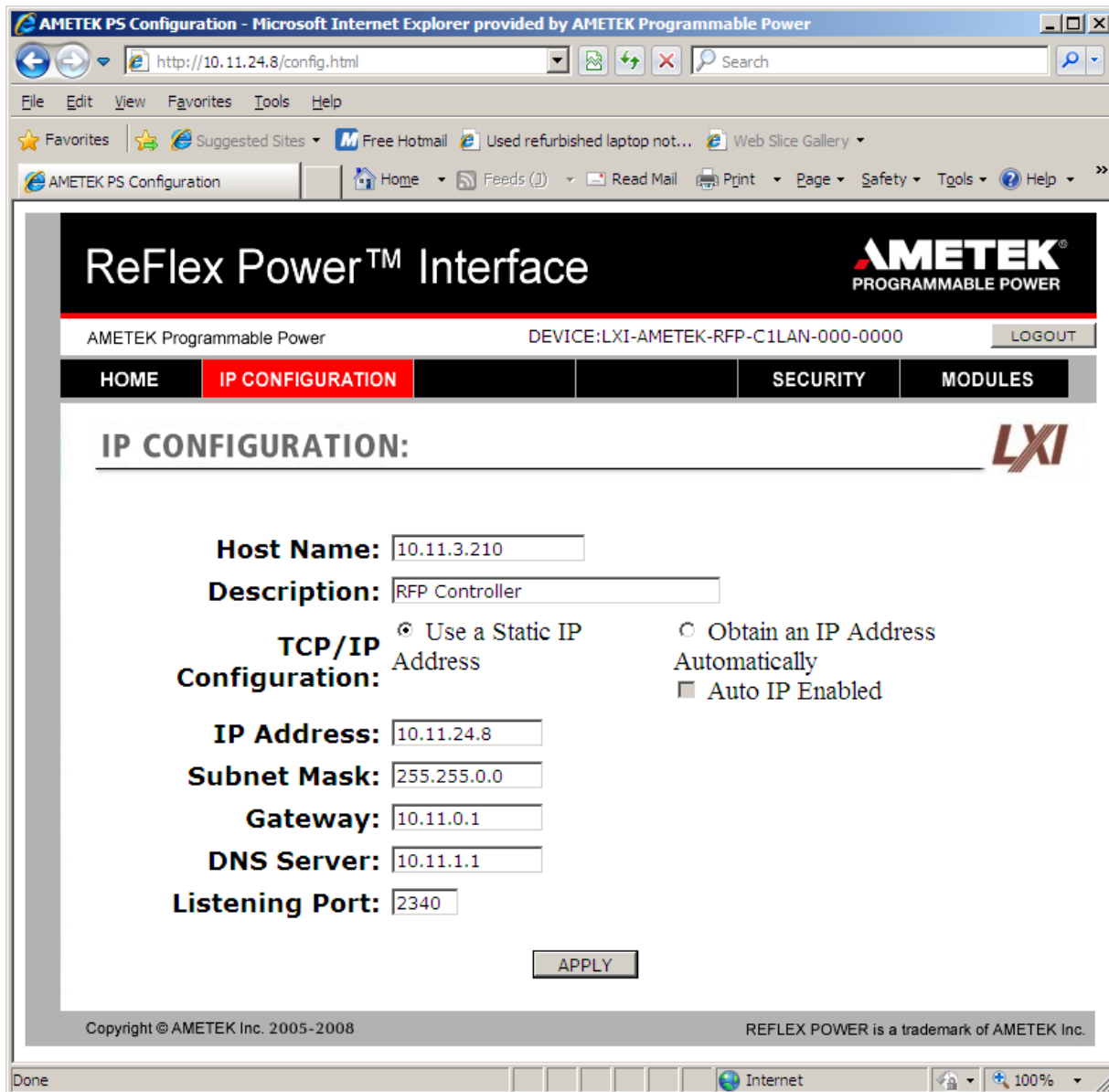

Figure 2-7. IP CONFIGURATION Static IP selected, but not yet applied.

When an IP Address is in error, it needs to be “checked”, an error message is displayed, and the page refreshes back to the previous settings. (Figure 2-8) An invalid IP address can be the result of invalid values entered in the address fields, or the requested IP address is already in use. The chosen IP address should be ‘PINGED’ to check that it is free and available for use before trying to set the RFPC to that address.

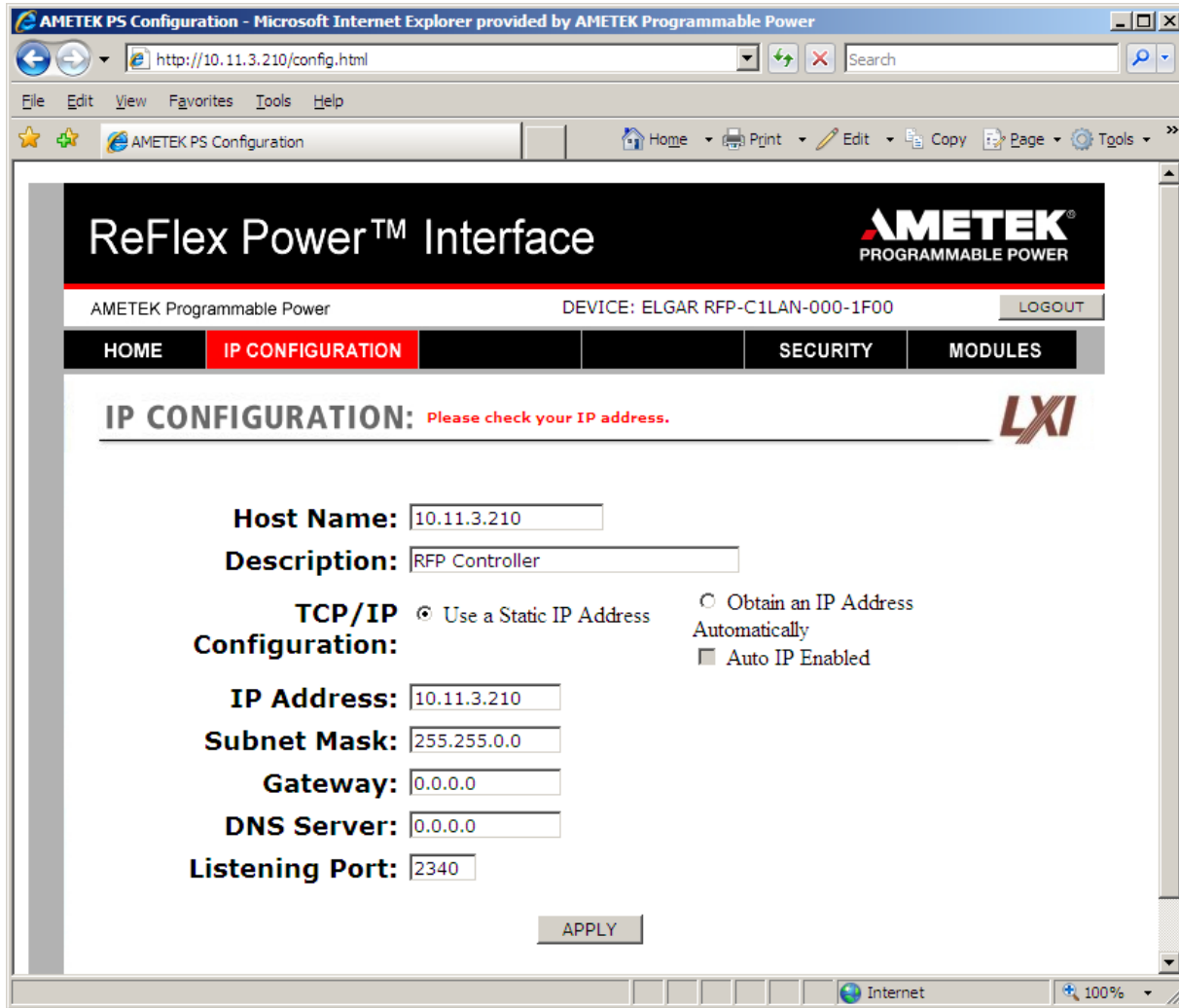

Figure 2-8. IP CONFIGURATION Page with Error Message for invalid IP Address

2.5.4 SECURITY PAGE

Click the SECURITY tab to open the Security page, which displays the user names and their permissions. (Figure 2-9)

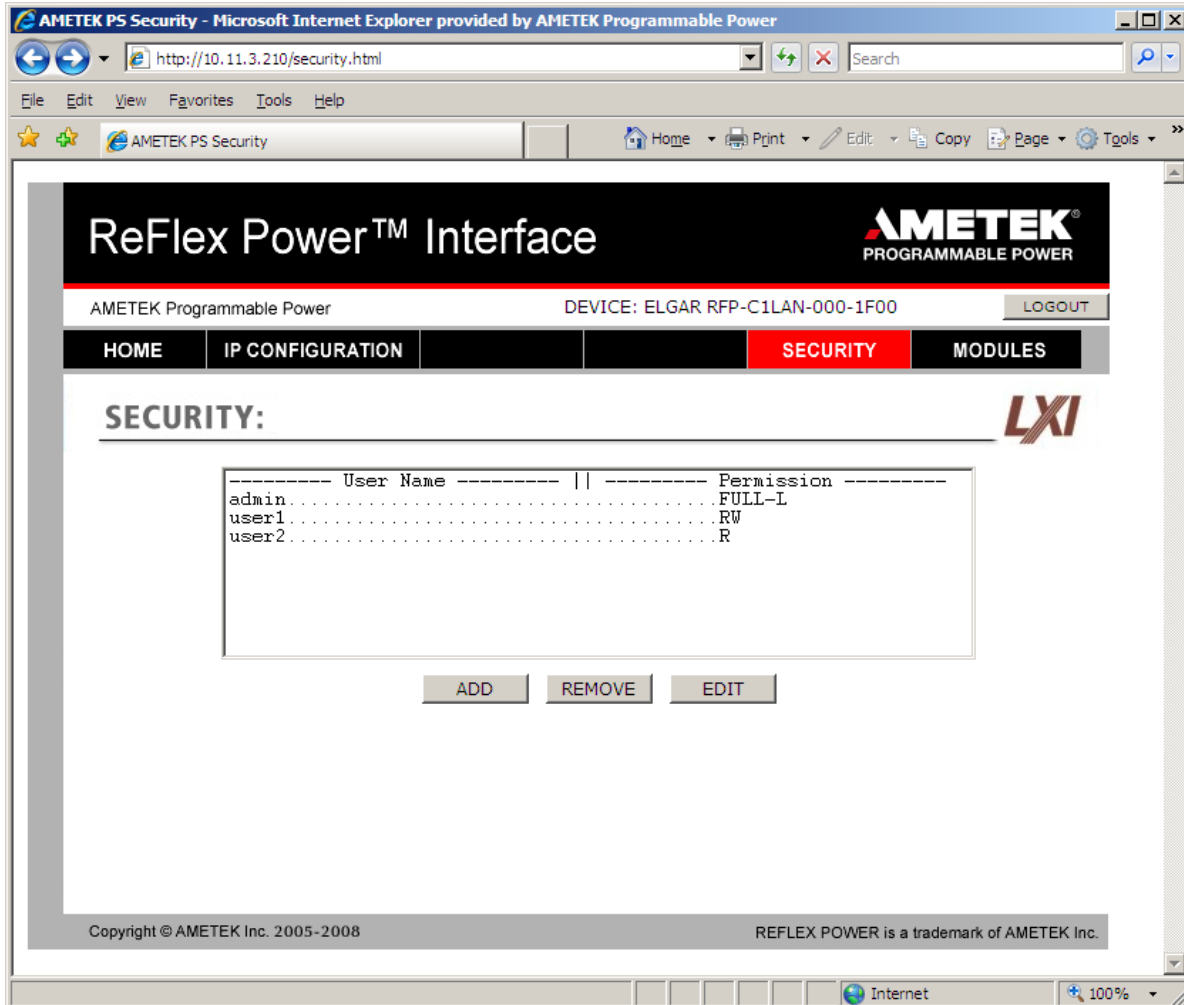

Figure 2-9. Security Page

Click the **ADD** button to add a new user and assign Password and Permissions (Figure 2-10). . To remove an existing user, select that user's name and click the **REMOVE** button. That row is deleted from the main Security page. To change anything for an existing user, select that user's name and click the **EDIT** button, which takes you to the EDIT EXISTING USER page (Figure 2-11).

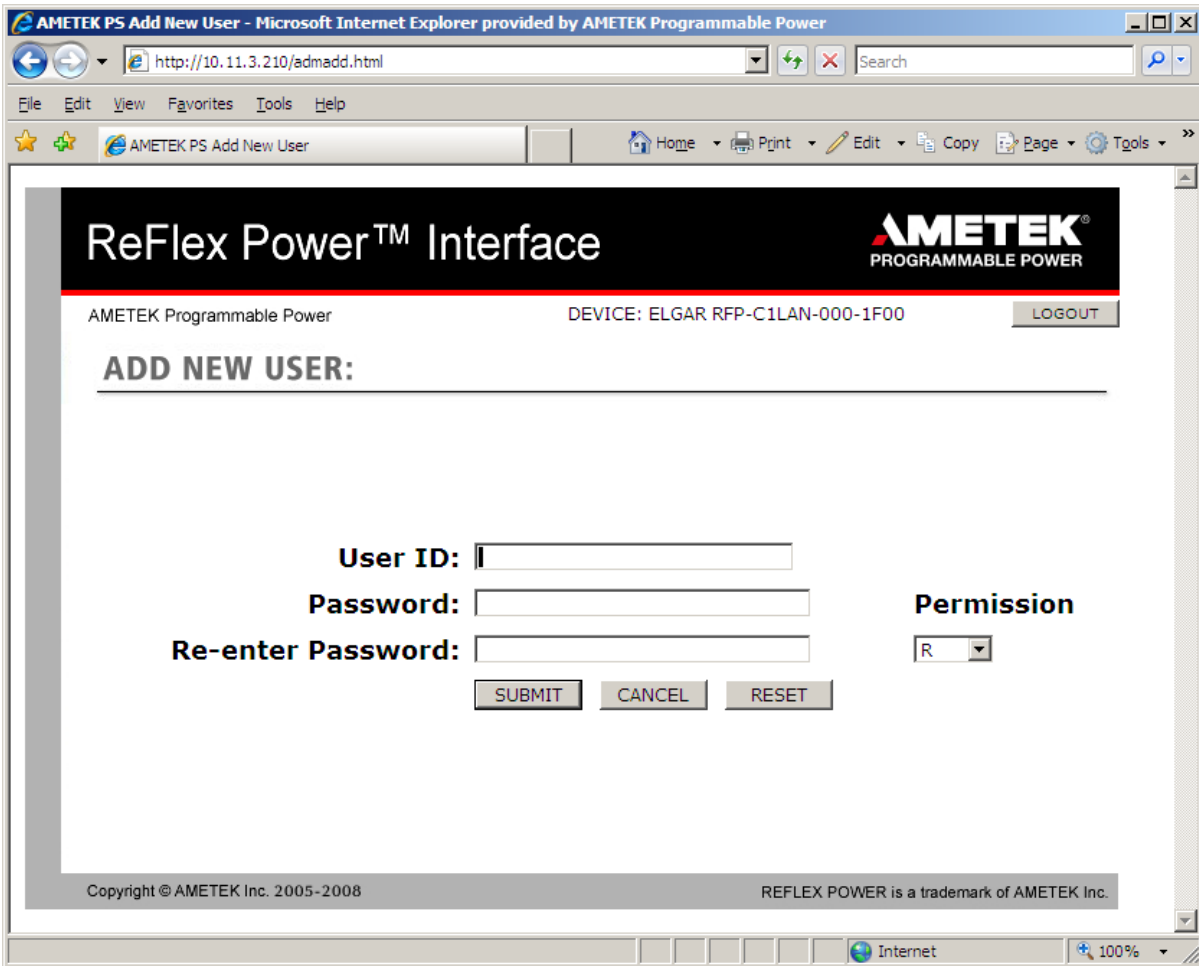

Figure 2-10. Security: Add New User

In the ADD NEW USER page, click the cursor in each field and type the inputs, select the Permission level from the drop-down menu and click the **SUBMIT** button to set the new user settings. To clear the fields and start over, click the **RESET** button. Clicking the **CANCEL** button reverts back to the previous Security page without changes taking effect.

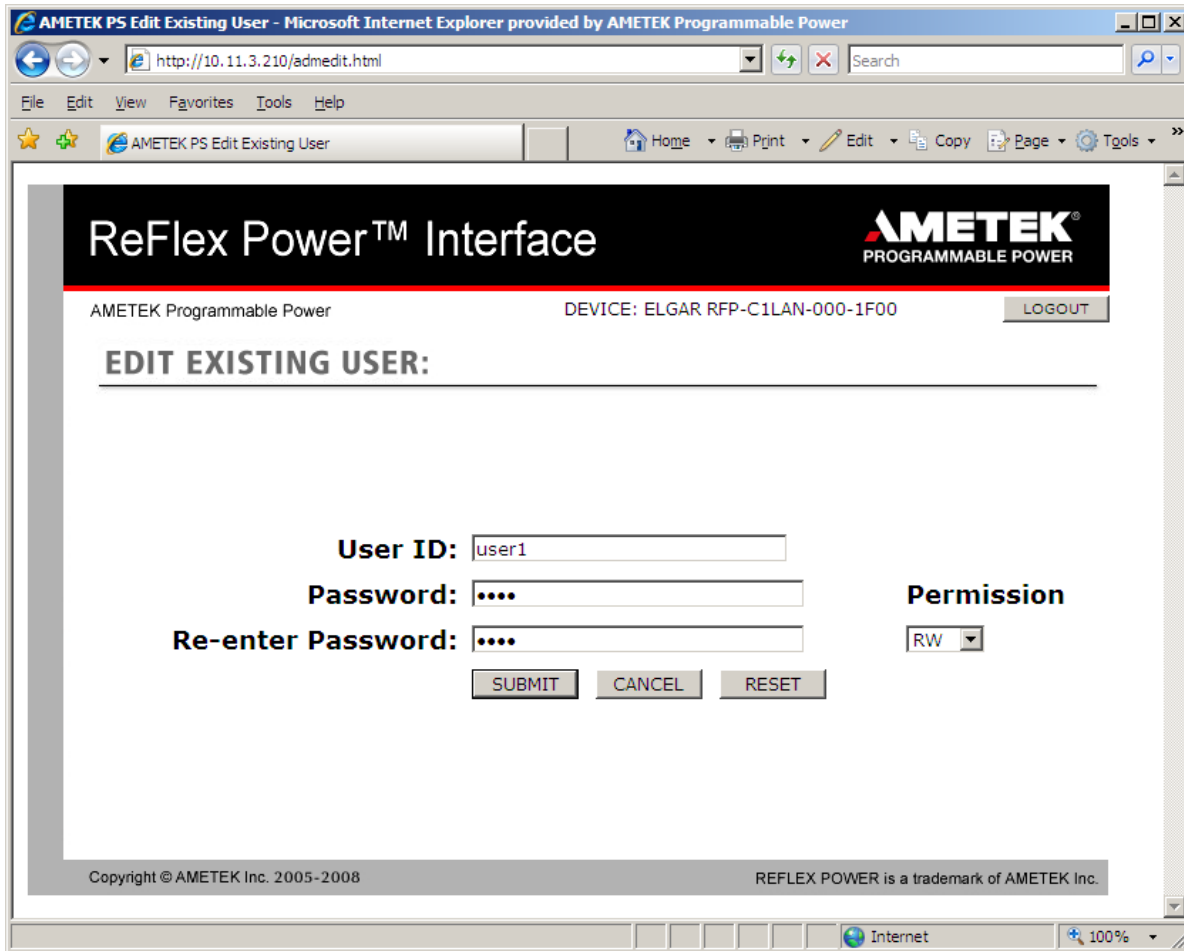

Figure 2-11. Security: Edit Existing User

Make the desired changes to the applicable fields and click the **SUBMIT** button to set the new user settings. To clear the fields and start over, click the **RESET** button. Clicking the **CANCEL** button reverts back to the previous Security page without changes taking effect.

2.5.5 MODULES PAGE

Click the **MODULES** tab to reveal the “address” or Slot Location (SL), the model number, the serial number and the firmware revision of the modules that are installed in the system. (Figure 2-12 shows a system with the ReFlex Power™ Controller module in Mainframe slot 1, and three AC power modules, in slots 5, 8, and 12).

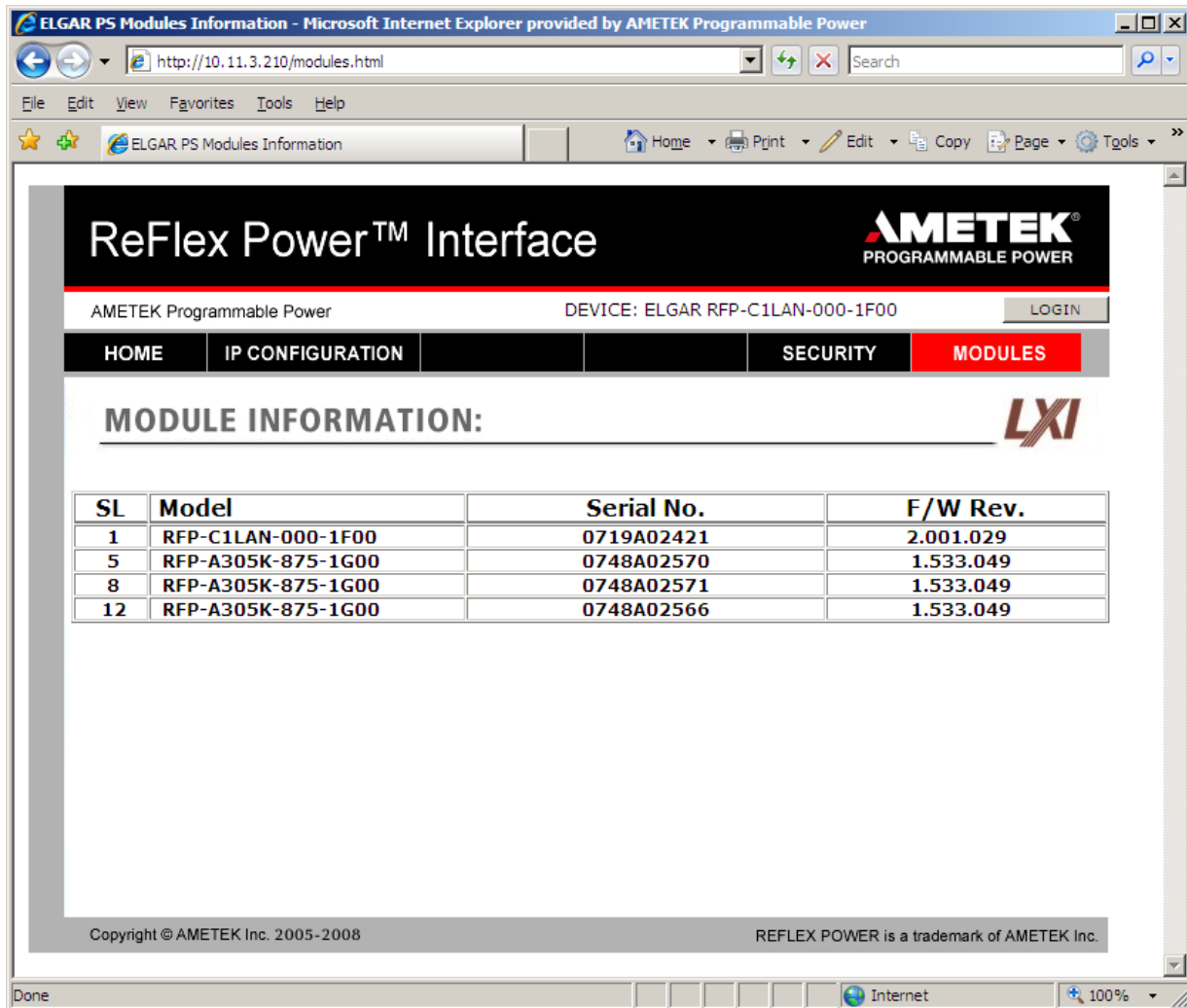

Figure 2-12. MODULES Page Showing Installed Power Modules

2.6 LAUNCHING CONTROL COMMUNICATION

Once the Ethernet interface is up and running, start the communication program as follows:

1. Copy the EnetTest.exe file supplied on the ReFlex Power™ CD-ROM into any convenient directory on the control computer.
2. In its new location double-click the EnetTest.exe file.

This brings up the Elgar Net Test window (Figure 2-13) where the Host IP and Port addresses must be set before control communication can begin.

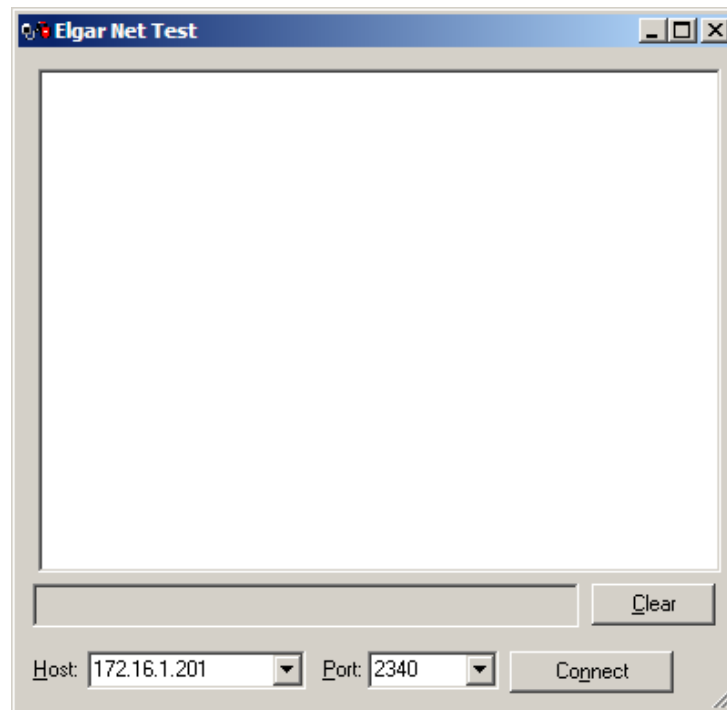

Figure 2-13. Net Test Window

In the Host and Port fields of the Net Test window:

3. Enter the Host IP address acquired by the LXI™ Discovery Browser (Section 2.4.3), or the static IP address that you entered in the Ethernet Configuration page (AutoIP will be in the range of 169.254.[1 thru 254].[0 thru 255].
4. Set the Port address to: 2340 (required)
5. Click the Connect button.

The field to the left of the **C**lear button, now appears white (not grayed out), to allow SCPI command input.

It may be necessary to change the IP address, due to address conflicts and other system requirements. (SYSTem:NETwork:IP <ipaddress>).

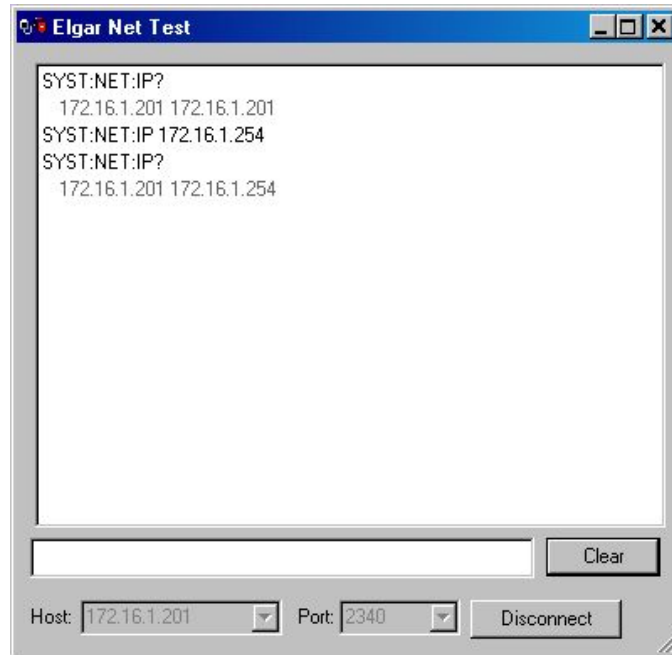

Figure 2-14. Query IP Address Example

Figure 2-14 displays an example of querying and changing the IP address to static. Note that the response to the IP address query after the address is changed, includes the current IP address followed by the new IP address. The following are commands associated with setting and querying the IP address:

SYSTem:NETwork:IP? Query to get the IP address from the ReFlex Power™ system.

SYSTem:NETwork:IP <ipaddress> Sets the ReFlex Power™ system IP address following the format:
NNN.NNN.NNN.NNN

The ReFlex Power™ System will reconfigure it's TCP/IP address to the requested address, after validating that the requested address is valid and available for use. When the IP address is set, the IP address configuration is automatically set to static.

When the IP address is reconfigured, all current TCP/IP connections are closed, and new connections at the new address will have to be created to communicate with the ReFlex Power™ System.

Test the communication interface by issuing the *IDN? and/or *IDN<n>? commands, which will return, respectively, the Controller's or specific module's model and firmware versions without affecting output.

2.6.1 MODULE LOCATION IDENTIFICATION (ADDRESS)

To control a specific module, use its address identified by its location in the ReFlex Power™ Mainframe. Each Mainframe houses 12 address locations, one for each single-width slot; the first slot on the left is numbered 1; the last on the right is numbered 12. Additional mainframes continue the count; i.e., the second Mainframe addresses are 13 through 24 from left to right (Figure 2-15). The address for a double or triple-width module is always the rightmost slot position that it occupies. Hence, a triple-width module covering slots 17, 18, and 19 is identified by address 19.

A ReFlex Power™ system is extendable up to eight (8) chassis, with the first mainframe chassis (primary) configured as output only; any intervening chassis would have both input and output inter-chassis connections, and the last would be configured as input only. Refer to the ReFlex Power™ Operation Manual (M380056-01) for additional information on multiple chassis interconnection requirements.

Primary mainframe, output only	1	2	3	4	5	6	7	8	9	10	11	12
Last mainframe, input only	13	14	15	16	17	18	19	20	21	22	23	24

Figure 2-15. Address Location and Chassis Configuration

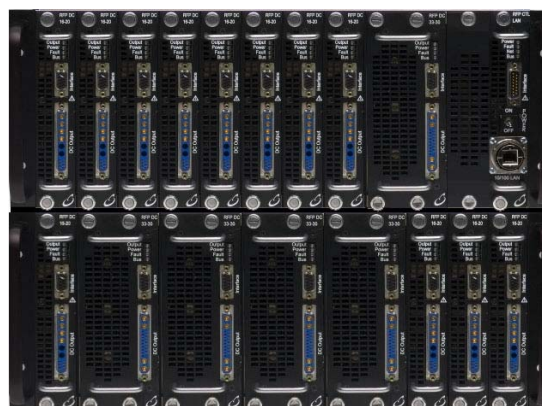

Figure 2-16. Photo of Multi-Chassis ReFlex Power™ System

2.6.2 COMMUNICATION WITH THE SYSTEM

Click within the Net Test window (Figure 2-14) to begin control communications by inputting SCPI commands per the proper syntax and conventions described herein.

2.7 SCPI COMMAND OPERATION

The SCPI command sets provide programming, query, and status commands that facilitate remote control of the ReFlex Power™ system.

The system supports the SCPI 1999.0 status reporting data structures. These structures are comprised of status registers and status register enable mask pairs. The following sections describe these pairs.

2.7.1 ERROR/EVENT QUEUE

The Error/Event Queue, defined by SCPI holds up to ten error events. Issue the `SYSTem:ERRor?` query to read the queue in a First In/First Out (FIFO) manner. The read operation removes the entry from the queue. Issue the `*CLS` command to clear all entries from the queue.

The following SCPI-defined error codes are in the range of [-32768, 32767]. SCPI reserves the negative error codes and 0, while error codes greater than 0 are device-specific errors.

Table 2-2. SCPI Error Codes

Error Code	Description
0	No Error The error queue is empty.
2	Invalid Index When a command is issued to an empty slot
11	Wrong Module Type Command is not correct for the specific module type.
12	Feature not supported Specific command may not get implemented for the module type
14	Feature Not Implemented Command will be implemented in the future
15	System too Busy System is busy executing a previous command, the command causing this error will not be executed.
206	TrigChannel not available Requested trigger channel is already used in the system
251	Wrong Group Config/Oper Group creation failed for stated reason.
252	Module inhibited asserted Module Inhibit is asserted in the RFPC for the ReFlex Power™ system.
253	List Seq Buffer Full The LIST being created, is too long.
-102	Syntax error An unrecognized command or data type was encountered.
-200	Execution error A command could not be executed due to the current condition of the module.
-222	Data out of range Parameter exceeded range of valid values.
-292	"Name not found/invalid Requested File name either not found or the name was not valid.
-293	Name already exists Requested name already exists.
-331	System Error A valid command could not be executed due to some internal/earlier error.
-350	Queue overflow The error queue can contain up to ten entries. If more than ten error/event conditions are logged before a SYSTem:ERRor? Query, an overflow will occur; the last queue entry will be overwritten with error -350. When the queue overflows, the least recent error/events remain in the queue and the most recent error/events are discarded.

2.8 LXI™ AND SCPI CONFORMANCE INFORMATION

The ReFlex Power™ Controller Ethernet is IEEE 802.3 and LXI™ (LAN eXtensions for Instrumentation) class C compliant.

The syntax of all SCPI commands implemented by the ReFlex Power™ system and documented in this manual, are either SCPI confirmed in the SCPI 1999.0 Specification, Volume 2: Command Reference, or they are customized commands not part of the SCPI definition, but conform to SCPI syntax.

2.8.1 PARAMETER DEFINITIONS

Table 2-3. Parameter Definitions

Type	Valid Arguments
<bool>	1 or "ON"; 0 or "OFF"
<NRi>	The data format <NRi> is defined in IEEE-488.2 for integers. Zero, positive and negative integer numeric values are valid data.
<0+NRi>	Zero and positive integer numeric values.
<-NRi>	Negative integer numeric values.
<NRf>	The data format <NRf> is defined in IEEE-488.2 for flexible Numeric Representation. Zero, positive and negative floating point numeric values are some examples of valid data.
<0+NRf>	Zero and positive floating point numeric values.
<-NRf>	Negative floating point numeric values.
<string>	Characters enclosed by double quotes.
<n>	The address number of the module in the RFP chassis system.

Note: Channel number 0 is invalid for any auxiliary device, because the ReFlex Power™ implementation of the SCPI language reserves channel 0 for the "global" address to address all channels.

2.8.2 NUMERIC DATA DIMENSIONAL UNITS

The Ethernet interface accepts dimensional units for numeric values of parameters as listed below. For example, the command `SOUR:VOLT 115` programs 115.0 volts when setting the output voltage of the supply.

Table 2-4. Numeric Data Units

Parameter	Dimensional Unit
Voltage	Volt
Current	Ampere
Time	Seconds
Frequency	Hertz
Phase Angle	Degrees

2.8.3 CONVENTIONS

Optional keywords and parameters are enclosed by left and right square brackets: []. The parameter <n>, in a command, indicates the address number of the module being commanded.

- Discrete module numbers are separated by commas: <n,n,n>.

- If nothing is entered, the default global command is automatically selected, if the global context can be logically correct.

Required input parameters are enclosed by left and right less-than / greater-than brackets: < > in the format indicated. For example:

- <bool> 0 or 1, for Off or On, respectively.
- <string> alphanumeric string enclosed by double quotes.
- <NRf> defined in IEEE 488.2 for flexible Numeric Representation, e.g., zero, positive and negative floating point numeric values.
- <NRi> defined in IEEE 488.2 for integers, e.g., zero, positive and negative integer numeric values.
- <t> indicates Trigger channel input/output connections (applies only to Controller and programmable DC modules; see the Trigger command section of this manual for further details on the <t> parameter).

The shorthand version of a command is indicated by capital letters (minimum required components of a command). For example, SOURce <n>:VOLTage <NRf>, can be written as:

- SOURCE<n>:VOLTAGE 120 //set output voltage to 120.0V
- SOUR<n>;VOLTAGE 120.0 //set output voltage to 120.0V
- SOUR<n>:VOLT 120 //set output voltage to 120.0V

2.8.4 QUERY SYNTAX

The query syntax is identical to the command syntax, but with a question mark (?) replacing the command's argument. For example, to query the programmed output voltage on a Module at address 1, send the command, SOUR1:VOLT?. A Module number is required. A value such as 65.00 will be returned when read.

The ReFlex Power™ Controller requires all commands received to be terminated with any combination of CR (0x0D) and or LF (0x0A). All responses are terminated by default with CR/LF (0x0D 0x0A). Response termination can be changed by using SYST:NET:TERM <NRi>. Each new user connection is always initializes to CR/LF.

2.9 COMMON SCPI COMMANDS

Table 2-5 shows commands that are common to all SCPI instruments.

Table 2-5. Common SCPI Commands

Command	Description
*CLS	Clears all status reporting data structures including the Status Byte, the Standard Event Status Register, the Protection Event Status Register, and the Error Queue. Enable registers are not cleared by this command.
*IDN<n>?	Returns the device identification as an ASCII string. Response: <Manufacturer>,<model>,<serial number>,<firmware version> Example: ELGAR,RFP-C1LAN-000-0000,1234A56789,3.000.001
*OPC<n>?	Operation Complete Query: Returns value of 1, when all pending operations are complete. Returns value of 0, when long, or multipart commands are not complete.
*STB?	Query User's SStatus Byte
*SRE?	Query the user's enable bits in the Service Request Enable register
*SRE <NRi>	Set the enable bits in the Service Request Enable register
*ESR?	Query the user's standard Event Status Register, if bit 0 is set, a *RST is required.
*ESE?	Query the user's Enable Standard Event status register
*ESE <NRi>	Set the user's enable bits in the Enable Standard Event status register.
*RST<n>	Resets the specific slot module to its Power ON state. Clears status reporting data structures, including the Protection Condition Status Registers. Enable registers are not cleared by this command. *RST will reset all modules.
*TST<n>	Initiate self test NOTE: Module must be OUP:STATE 0 and not a group member.
*TST<n>?	Returns the results from the last self test the module performed. Returns a decimal value, convert to Hex because more than one bit can be set. See Table 2-6

Table 2-6. Module *TST? Error Response Bits

Response	Definition for all Modules
0x00	No Selftest Errors
0x01	The Firmware Version of the Controller and Module are not compatible
0x02	Flash image A, tag mismatch
0x04	Flash image B, tag mismatch
0x08	Isolation relay closed
0x10	Sense relay closed
0x20	Current measurement error. For DC, measured current not zero.
0x40	Voltage measurement error
0x80	Output turn on error
0x100	RAM Configuration error
0x200	Module Enable false
0x400	Module On, Active selftest not run
0x800	OVP test failed
0x1000	UVP test failed
0x2000	Housekeeping supply fault
0x4000	Overtemp fault
0x8000	Ground fault
0x10000	Tried to run selftest on a Group Member
0x20000	OCP test failed
0x40000	Configuration or Calibration file error

2.10 EIB SCPI COMMANDS

The EIB (Elgar Interface Bus) subsystem is a proprietary set of customized commands, conforming to SCPI syntax but not defined by the SCPI Standard.

2.10.1 EIB SCPI COMMAND SUMMARY

```
EIB
  :CONFigure
  :DNUMber?
    :INFormation
      :ALL?
      :VERBose?
    :LADDRESS?
```

2.10.2 EIB SCPI COMMAND REFERENCE

Command	Description
EIB	EIB subsystem.
:CONFigure	CONFigure sub-commands
:DNUMber?	Returns the number of devices in the system including the controller.
:INFormation	
:ALL?	Returns the model information string of the devices in the system.
:VERBose?	Returns the model information string of the devices in the system with the corresponding logical Address.
:LADDRESS?	Returns the logical Address of the devices in the system; the first address is that of the controller.

2.11 SYSTEM:NETWORK SCPI COMMANDS

2.11.1 SYSTEM:NETWORK SCPI COMMAND SUMMARY

```
SYSTEM
  :ERRor?
  :VERsion?
  :FAULt?
  :MODSRQ?
    :NETwork
      :AUTOIP <bool>
      :AUTOIP?
      :DESC <string>
      :DESC?
      :DHCPMODE <bool>
```

```

:DHCPMODE?
:DNS <IP Address>
:DNS?
:GATE <IP Address>
:GATE?
:HOST <string>
:HOST?
:IP <IP Address>
:IP?
:LANLED BLINKON
:LANLED BLINKOFF
:LANLED?
:MAC?
:MASK <IP Address>
:MASK?
:PING <IP address>?
:PORT <NRi>
:PORT?
:TERM <NRi>
:TERM?
    
```

2.11.2 SYSTEM:NETWORK SCPI COMMAND REFERENCE

Command	Description
SYSTem	System subsystem.
:ERRor?	Queries Error Queue for next error/event entry (first in, first out). Entries contain an error number and descriptive text. A 0 return value indicates no error occurred; negative numbers are reserved by SCPI. The maximum string length returned is 255 characters. The queue holds up to 10 error/entries. All entries are cleared (per user) by the *CLS command.
:VERsion?	Returns the SCPI version number for the instrument. The response is in the format YYYY.V where the Y's represent the year and V represents the approved version number for that year (e.g., 1999.0)
:FAULt? ³	Returns a Hex number. If a module has an active Hardware fault condition, the corresponding bit will be a '1', else '0'.
:MODSRQ? ^{2,3}	Returns a Hex number. If a module has an active SRQ event, the corresponding bit will be a '1', else '0'.
:NETwork	Network Subsystem
:AUTOIP <bool> ¹	Sets the network Auto IP mode. 0 = disable AutoIP; 1 = enable AutoIP
:AUTOIP?	0 = AutoIP disabled; 1 = AutoIP enabled.
:DESC <string>	Set the network Description, a 64 character alphanumeric string surrounded by quotes
:DESC?	Returns the network Description.
:DHCPMODE <bool>	1 = enable, 0 = disable DHCP mode. Reboot to take effect.
:DHCPMODE?	Returns Y if DHCP Mode is enabled. Returns N if DHCP mode is disabled.

Command	Description
:DNS <IP address>	Set the IP address of the Domain Name System for the device (IP address is in the format NNN.NNN.NNN.NNN where “NNN” = 0 through 255, inclusive).
:DNS?	Returns the network DNS address for the device.
:GATE <IP address>	Sets the network gateway IP address for the device. The IP address format is NNN.NNN.NNN.NNN where “NNN” = 0 through 255, inclusive.
:GATE?	Returns the network gateway IP address for the device.
:HOST <string>	Set the network Host Name, a 15-character (maximum) alphanumeric quoted “string”.
:HOST?	Returns the network Host Name
:IP <IP address>	Configures the RFPC to STATIC IP mode, delays several seconds, closes all network connections, then uses the new IP address. The IP address format is NNN.NNN.NNN.NNN, where “NNN” = 0 through 255, inclusive.
:IP?	Returns two IP addresses: the first is the IP address presently in use by the power supply; the second is the IP address to be used when the system re-configures.
:LANLED <BLINKON BLINKOFF>	BLINKON blinks LAN LED. (Used to identify which RFPC in a rack is being addressed). BLINKOFF stops LAN LED blinking.
:LANLED?	Returns state of the LAN LED: 0 – Off; 1 – On, 2 - blinking.
:MAC?	Returns the network MAC address. xx-xx-xx-xx-xx-xx (Hexadecimal digit pairs)
:MASK <IP address>	Set the network Subnet Mask for the device. The mask is in the format NNN.NNN.NNN.NNN where “NNN” = 0 through 255, inclusive.
:MASK?	Returns the network Subnet Mask for the device.
:PING <IP address>?	Pings the IP address and returns the statistics
:PORT <NRi>	Set the network TCP/IP socket listening port. The Port address is not changeable.
:PORT?	Returns the network TCP/IP socket listening port address, which is 2340.
:TERM <NRi>	Set the return string terminator to be sent by the device. The valid range is 1-4. The TERM value is user specific, for each individual connection lifetime. Connection Default is 3. Values indicate the following terminator(s): 1 = 0x0D only (CR), 2 = 0x0A only (LF), 3 = 0x0D 0x0A (CR LF), 4 = 0x0A 0x0D (LF CR)
:TERM?	Returns the string terminator value used by the device.

¹ When an AutoIP address is acquired, it's range will be 169.254.1-254.NNN

² To receive SRQ events at a host computer, a “TCPIP0::10.11.3.210::inst0::INSTR” connection must be instantiated by the IVI Driver, and the user application must call the proper initialization and setup routines.

³ The Hex formatted number is 96 bits in length, which has a one-to-one correspondence for each possible module in the system. The bits are numbered 96 down to 1.

2.13 RFP SERVICE REQUEST

2.13.1 BACKGROUND

The idea of Service ReQuest (SRQ) generation over Ethernet in RFP is to allow the system to selectively and asynchronously alert each user to specific events that have occurred in the system depending on which modules are SRQ enabled. Because SRQ's are asynchronous, the instrument does not require to be polled, which lowers overhead and bandwidth requirements.

The RFP system provides a command and control interface via Ethernet. Because the client side implementation of SRQ for Ethernet is implemented using SUN RPC™ and VXI-11™ protocol, the RFPC implements a VXI-11 Server. A socket-based connection can set an SRQ event into the SStatus Byte register, (STB), but since there is no driver notification in this mode, it would only be detected in a polling mode.

2.13.2 THEORY OF OPERATION

The RFPC implements the RPC port 111-portmapper function for both TCP and UDP. This allows the client to acquire the port # for the VXI-11 Server. The VXI-11 Server connects to the client and translates the VXI-11 requests into a form that can be sent to RFP modules, and receives the responses from the RFP modules and formats them back into VXI-11 responses. The VXI-11 server can support 16 concurrent client connections.

The VXI-11 server receives SRQ events from the RFPC (if enabled) and sends (if SRQ enabled) a device interrupt request to the client.

The RFPC implements a multi-client SRQ mechanism based on the software model of the SCPI Status Register structure. The RFPC maintains a SCPI status and SRQ structure that is separate and unique per connection/user. The association of a module level SRQ and the user occurs when the user has programmed a module's Protection Event enable register (PEV) to a non-zero value, and disconnected when the module's PEV is set to zero, or the user closes the Ethernet session.

There are two classes of SRQ's, the first class is events generated from the standard Event Status Register, (ESR) and the second class is events generated from the module Protection Event register. (PE) The summary of all these events is located in the STB.

2.13.3 EVENT STATUS REGISTER

The standard Event Status Register (ESR) handles events that are generally caused by user commands. These include errors generated by command or execution errors. There is a corresponding Enable Standard Event register (ESE) that allows events to be enabled or masked off.

2.13.4 PROTECTION EVENT REGISTER

The Protection Event register (PE) handles all the events that are hardware related. There is a corresponding Protection Event enable register (PEV) that allows these hardware events to be enabled or masked off.

2.13.5 REGISTER ALLOCATION

The module level PE and PEV registers are allocated as one set, per module. There is also one set of PE/PEV registers that serve as summary accumulators. Also one set of STB, SRE, ESR, ESE registers, and an ErrorQueue, that are allocated on a per user basis.

A unique set of these registers are allocated per each TCP/IP Socket connection or VXI-11 channel connection, and released when the connection is closed.

2.13.6 EXECUTION TIME OPERATION

Group creation will clear both the PE and PEV registers at the module level.

If a PE, ESR, and STB event is active and the corresponding event in the ESE, PEV and SRE is enabled, a SRQ will be generated. If several simultaneous events occur, the first one will set the SRQ, to clear the SRQ, all succeeding events will also need to be cleared.

To clear an SRQ, there are several commands that have been implemented to make the job easier. The standard one of *STB?, is to see which class of interrupt has occurred, an Event Status Register, Error Queue, and or a Module Protection Event. The ESR is queried by the *ESR? command. Which module caused a SRQ event can be determined by a SYST:MODSRQ?. This command returns a 96 bit hex number (96 down to 1, Left to Right) on a user basis, that has a '1' bit set corresponding to each module number that the user has programmed non-zero PEV register value that has caused the SRQ to be asserted.

To clear a PE, use the SYST:MODSRQ? to determine which module(s) requires service, read their PE register. Then read the summaries PE register, if there are no further SRQ's pending, the SRQ bit in the STB register should clear. If not, check for other events that are pending.

The linkage between a client and the RFP SRQ mechanism is made when a module's **STATus<n>:PROtection:ENABLE<Ni>** bits are set non-zero. The *SRE and client side driver must also enable SRQ for one to occur. The summary set of PE/PEV registers can be used as a global SRQ enable/disable for module based events on a per user basis.

2.13.7 SRQ RELATED SCPI COMMANDS

SYST	System level command
:MODSRQ? ^{1,2}	Returns a Hex number. If a module has an active SRQ event, the corresponding bit will be a '1', else '0'.
:FAULt? ¹	Returns a Hex number. If a module has an active Hardware fault condition, the corresponding bit will be a '1', else '0'.
*	Star level commands
STB?	Query User's SStatus Byte
SRE?	Query the user's enable bits in the Service Request Enable register
SRE <Ni>	Set the enable bits in the Service Request Enable register
ESR?	Query the user's Standard Event status Register, if bit 0 set, a *RST is required.
ESE?	Query the user's Enable Standard Event status register
ESE <Ni>	Set the user's enable bits in the Enable Standard Event status register.
STATus<n>:PROTection	Module Status subsystem
:CONDection?	Returns a real-time copy of the module protection event bits
:EVENt?	Returns a summation of the module protection event bits, cleared on read.
:ENABle?	Query the module protection event enable bits
:ENABle<Ni>	Set the module protection event enable bits
STATus:PROTection	Summary Status subsystem
:EVENt?	A summation of the users module protection event bits, cleared on read.
:ENABle?	Query the users protection event enable bits
:ENABle<Ni>	Set the users protection event enable bits

¹ The Hex formatted number is 96 bits in length, which has a one-to-one correspondence for each possible module in the system. The bits are numbered 96 down to 1.

² To receive SRQ events at a host computer, a "TCPIP0::<TCP/IP Address>::inst0::INSTR" connection must be instantiated by the IVI Driver, and the user application must call the proper initialization and setup routines.

- 7 Over Current Fault
- 6 Volt|Curr Mode Fault
- 5 Module Disabled
- 4 Over Temperature Fault
- 3 Output Voltage Fault
- 2 Summary bit ¹
- 1 Constant Current Operation ²
- 0 Constant Voltage Operation ²

Note 1: Any changes in bits 7-3, 1-0 will set this bit.

Note 2: Short duration mode changes of < 50 mSec. may not be detected. For the Load Module: Bit 0 is for Resistance mode operation.

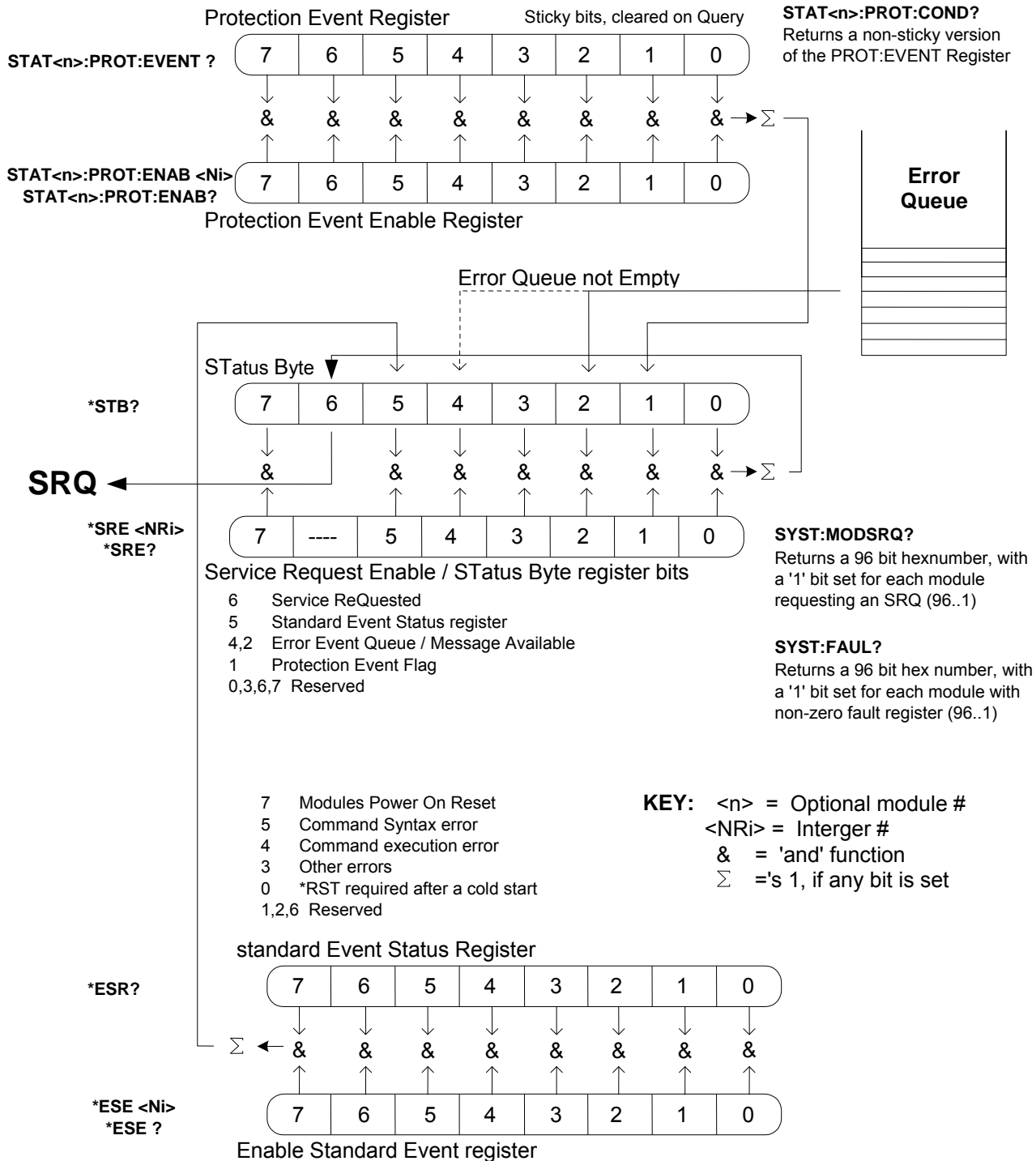

2.13.8 SETTING THE SRQ BIT IN THE STB, AN EXAMPLE

The following example shows the STB is initially zero. The SRE is enabled to set SRQ if Message AAvailable / Error Event Queue is asserted. A 'bad command' is sent to the RFP system, which causes the Error Queue to have an entry, which sets status bits in the STB. The setting of the bits in the STB that match bits set in the SRE, will then cause bit 6 (SRQ) to be set, which will generate the SRQ response if enabled by the host IVI-driver. To clear an SRQ, the cause of the SRQ must be cleared. In the example below, reading the Error Queue will cause the Message AAvailable / Error Event Queue bit to clear, if the Error Queue is empty, and if there are no other matching bits between the STB and SRE or STB and PE registers, the STB SRQ bit will clear, signaling the end of the SRQ event. The RFP system is now ready to generate another SRQ event. If the SRQ bit does not clear, then there is another pending SRQ event and the cause will need to be cleared before the SRQ event will end. If there is a pending but not enabled SRQ event pending and the corresponding bits in the ESE or PE registers are then set, this will then generate an immediate SRQ and the client will need to issue commands to clear these events before any other SRQ's will be recognized.

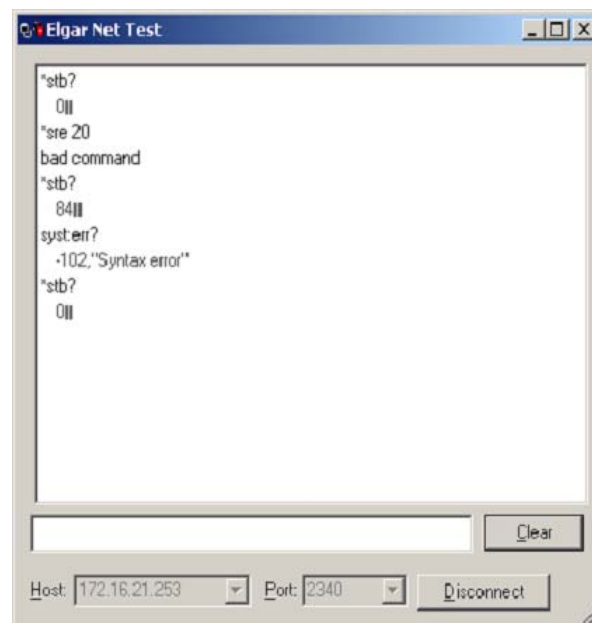

2.14 TRIGGER SCPI COMMANDS

The ReFlex Power™ Controller (RFPC) Trigger commands interact with the Trigger commands of the High Power/Low Power programmable DC modules, and not with any of the other modules. The role of the RFPC is to source trigger signals to and/or from its front panel or rear panel backplane buss. Please see the DC Module Remote Programming section of this manual for details and requirements.

2.14.1 TRIGGER SCPI COMMAND SUMMARY

TRIGger

```
:DISPlay?
:INP <t>, OUTP <t>
:OUTP <t>, INP <t>
:TRIGger <t>
```

TRIGger<t>

```
:ENABle
:DISABle
:SLOPe [POSitive | NEGative | BOTH | NONE]
:WIDTh<NRf+>
```

2.14.2 TRIGGER SCPI COMMAND REFERENCE

Command	Description
TRIGger	Trigger subsystem.
:DISPlay?	Displays a list of the module numbers that use the GPIO Buss signals.
:INP <t>, OUTP <t> :OUTP <t>, INP <t>	Map RFPC's GPIO Buss signals (t = a, b, c, or d) to Front Panel triggers (t = fa, fb, fc, fd), specifying direction. (one-one mapping)
:TRIG <t>	Generate a RFPC trigger, t = fa-fd.
TRIGger<t>	
:ENABle	t = fa - fd; RFPC Buss/Front Panel trigger enable
:DISABle	t = fa - fd; RFPC Buss/Front Panel trigger disable
:SLOPe [POSitive NEGative BOTH NONE]	t = fa - fd sets the RFPC Front Panel trigger input/output edge as positive, negative, or both. NONE disconnects the Buss to Front Panel connection.
:WIDTh<NRf+>	t = fa - fd sets the RFPC Front Panel trigger output pulse width. The WIDTh timing range is 2.0e-6 to 2.097 seconds.

This page intentionally left blank.

SECTION 3

DC MODULE REMOTE PROGRAMMING

3.1 INTRODUCTION

This section covers the remote programming of the ReFlex Power™ programmable DC power supplies, High Power DC (HPDC) and Low Power DC (LPDC). This interface enables operation of the HPDC and LPDC power supplies from a computer via the Ethernet, allowing full remote programming control and monitoring of the power supply.

The syntax of all SCPI commands implemented by the ReFlex Power™ system and documented in this manual, are either SCPI confirmed in the SCPI 1999.0 Specification, Volume 2: Command Reference, or they are customized commands not part of the SCPI definition, but conform to SCPI syntax.

3.2 FEATURES AND FUNCTIONS

FEATURES

- 16-bit programming and 16-bit readback of voltage and current
- Programmable over/undervoltage protection with reset
- Programmable overcurrent protection
- User selectable Constant-Voltage/Constant-Current mode, with reset
- Field-upgradeable firmware via Ethernet
- Soft calibration

PROGRAMMABLE FUNCTIONS

- Output voltage and current
- Soft limits for voltage and current
- Over/Undervoltage protection
- Programmable Overcurrent trip point
- Output enable/disable
- Maskable fault interrupt
- Full calibration

READBACK FUNCTIONS

- Actual measured voltage and current
- Voltage and current settings
- Soft voltage and current limits
- Over/Undervoltage protection setting
- Status and Accumulated Status registers
- Programming error codes
- Fault codes
- Manufacturer, power supply model, serial number, and firmware version identification

3.3 POWER-ON CONDITIONS

Table 3-1 presents remote power-on conditions for the programmable DC power supplies.

Table 3-1. Remote Power-on Conditions

Condition	Default
Voltage	0 Volts (initial power-on voltage). Also see CAL<n>:INIT:VOLT
Current	0 Amps (initial power-on current). Also see CAL<n>:INIT:CURR
Soft Voltage Limit	Model maximum voltage
Soft Current Limit	Model maximum current
OCP Trip Voltage	Model maximum current +20% (initial power-on OCP). See CAL<n>:INIT:CURR:PROT
OVP Trip Voltage	Model maximum voltage +7% (initial power-on OVP). See CAL<n>:INIT:VOLT:PROT
Output Relay State	Auto Close of ISOL/SENSE on :STATE 1 command
Output	OFF
Group	No Modules Grouped, (such as parallel)

3.4 ERROR CODES

The ReFlex Power™ system supports the SCPI 1999.0 status reporting data structures. These structures are comprised of status registers and status register enable mask pairs. The following sections describe these pairs.

3.4.1 ERROR/EVENT QUEUE

The programmable DC power supplies maintain an Error/Event Queue as defined by SCPI. The queue holds up to ten error events. Read it by issuing the `SYSTem:ERRor?` query, which reads in a First In/First Out (FIFO)

manner. The read operation removes the entry from the queue. The *CLS command will clear all entries from the queue.

The following error codes are defined in the SCPI 1999.0 specification and are supported by the DCPS. Error codes are in the range of [-32768, 32767]. SCPI reserves the negative error codes and 0, while error codes greater than 0 are device specific errors.

0, No error

The error queue is empty.

-102, Syntax error

An unrecognized command or data type was encountered.

-200, Execution error

This is a generic error when a specific error could not be identified. An execution error could be the result of the following condition:

A command could not be executed due to the current operational condition.

-222, Range Error

A <program data> element is out-of-range; for example, programming 150V, when the maximum allowed value is 135V.

-350, Queue overflow

The Error/Event Queue can contain up to 10 entries. If more than 10 error/event conditions are logged before the **SYSTem:ERRor?** query, an overflow will occur; the last queue entry will be overwritten with error -350. When the queue overflows, the least recent error/event remains in the queue and the most recent error/event is discarded.

NOTE: Some SCPI commands will generate the following replies, which can be viewed with the SYST:ERR? command:

REPLY	DESCRIPTION
Invalid 5PCalData	Error occurs at the boot up sequence if the 5-point calibration data are not valid.
Unable to open Module Data file - file system problem	Error occurs at the boot up sequence if the module data file does not open
Invalid Password.	CAL<n> : UNLOCK "Password" [to unlock the files to store the calibration or module data, but password used is incorrect]
Unable to open Module Data file - file is locked	The CAL<n> : UNLOCK command is not used before using CAL<n> : STORE command
Ignored Redundant 'State On' command	OUTP<n> : STATE <bool> [to power on or off the DC module]

REPLY	DESCRIPTION
Unable to change Output State - Output Inhibited	OUTP<n>:STATE <bool> [to power on or off the DC module
Unable to change Output State	OUTP<n>:STATE <bool> [to power on or off the DC module
Relay hot-switching prohibited or Parallel Slave	OUTP<n>:STATE <bool> [to power on or off the DC module
Unable to close Default Sense Relay, Default Isol Relay is open	User tries to close the sense relay with the CAL<n>:INIT:DEFAULT:SENSE <bool> command when the isolation relay is open
Unable to open Output Relay, Sense Relay is closed	User tries to open the isolation relay with the CAL<n>:INIT:DEFAULT:ISOL <bool> command when sense relay is closed
Relay hot-switching prohibited	User tries to open the isolation relay with the OUTP<n>:ISOL <bool> command when the output voltage is on
Unable to change Polarity, an Output or Sense relay is closed	User tries to change the polarity of the module with the OUTP<n>:POL <bool> command when Isolation and sense relay is closed
Unable to close Sense relay, Output Relay is NOT closed	User tries to close the sense relay with the OUTP<n>:SENSE <bool> command when the isolation / output relay is not closed
Module Firmware too old to support this RFP Controller Firmware Revision	The addressed module's firmware version is too old to be compatible with the RFPC's firmware

3.5 COMMON SCPI COMMANDS

The following commands are common to all SCPI instruments and declared mandatory by IEEE-488.2. In the following table, the DCPS is defined as the "device" on the bus.

Table 3-2. Common SCPI Commands

Command	Description
*CLS<n>	Clears module hardware faults latch
*IDN<n>?	Returns the device identification as an ASCII string. Response: <Manufacturer>,<model>,<serial number>,<firmware version> Example: ELGAR,RFP-D1016-021,1234A56789,3.000.001
*OPC<n>?	Operation Complete Query: Returns the integer value "1" when all pending operations are complete.
*RST<n>	Resets the supply to its Power ON (PON) state. Clears status reporting data structures the Protection Event and the Condition Status Registers. Enable registers are not cleared by this command. RST will reset all modules.

Command	Description
*TST<n>	Initiate self-test
*TST<n>?	Returns the results from the last self test the module performed. Returns a decimal value, convert to Hex because more than one bit can be set. See Table 2-6

3.6 CALIBRATION SCPI COMMANDS



CAUTION

Before attempting to execute any of the HP/LP DC power supplies calibration commands, follow the calibration procedures in the ReFlex Power™ Operation Manual (M380056-01), DC Power Supplies Section. Qualified personnel who are appropriately trained to deal with attendant hazards must perform calibration. If calibration is not performed properly, functional problems could arise, requiring that the supply be returned to the factory.

3.6.1 CALIBRATION SCPI COMMAND SUMMARY

```

CALibrate[n]
  :INITial
    :CURRent <0+NRf>
      [:AMPLitude] <NRf>
      [:AMPLitude]?
      :PROtection <NRf>
      :PROtection?
    :VOLTage <0+NRf>
      [:AMPLitude] <NRf>
      [:AMPLitude]?
      :PROtection <NRf>
      :PROtection?
    :STATe <Bool>
    :STATe?
    :UNDERVOLTage
      :PROtection <NRf>
      :PROtection?
    :DEFAult
  :OUTPut
    :CURRent
      :COUNTS <NRi>
      :FIVEPOINT<1-5> <NRi>
      :FIVEPOINT?
      :PROtection
        :COUNTS <NRi>
    :VOLTage
      :COUNTS <NRi>
      :FIVEPOINT<1-5> <NRi>
      :FIVEPOINT?
      :PROtection

```

```

:COUNTS <NRi>

:MODule
  :VOLTagE?
  :CURRent?

:LOCK
:STORe
:UNLock <string>
    
```

3.6.2 CALIBRATION SCPI COMMAND REFERENCE

Command	Description
CALibrate<n>	Calibration subsystem. Module 'n'.
:INITial	
:CURRent	
[:AMPLitude] <NRf>	Sets the power-on default value of current.
[:AMPLitude]?	Query the power-on default value of current
:PROTection <NRf>	Sets the power-on default value of the over current protection.
:PROTection?	Query the power-on default value of the over current protection.
:VOLTagE	
[:AMPLitude] <NRf>	Sets the power-on default voltage. Should be set to zero volts to avoid hot switching of output relay.
[:AMPLitude]?	Query the power-on default voltage. Should be set to zero volts to avoid hot switching of output relay.
:PROTection <NRf>	Sets the power-on default value of the over voltage protection.
:PROTection?	Query the power-on default value of the over voltage protection.
:STATe <bool> ¹	Set the initial POR output state of the unit
:STATe?	Query the initial POR output state setting of the unit
:UNDERVOLTagE	
:PROTection <NRf>	Sets the power-on default value of the under voltage protection.
:PROTection?	Query the power-on default value of the under voltage protection.
:DEFault	Sets initial settings to Factory defaults of 0.0 Volts/Amps/UVP, OVP/OCP to Module Max values and POR State to Off.
:OUTPut	
:CURRent	
:COUNTS <NRi>	Set Current DAC
:FIVEPOINT<1-5> <0+NRf>	Sets the current output calibration point (1 through 5). The actual output current is measured with an external meter.
:FIVEPOINT?	Returns 5 pairs of current calibration setpoint count and related current values
:PROTection	
:COUNTS <NRi>	Set Protection value 0-4095

Command	Description
:VOLTage	
:COUNTS <NRi>	Set Voltage DAC
:FIVEPOINT<1-5> <NRF>	Sets the voltage output calibration point (1 through 5). The actual output voltage is measured with an external meter.
:FIVEPOINT?	Returns 5 pairs of voltage calibration setpoint counts and related voltage values
:PROTEction	
:COUNTS <NRi>	Set Protection value 0-4095
:MODule	
:VOLTage?	Returns Module Voltage rating
:CURRent?	Returns Module Current rating
:LOCK	Disables access to the non-volatile memory. Prevents attempts to store calibration values.
:UNLock <string>	Sets the non-volatile memory available to store calibration constants. The access string is "6867".
:STORE	Stores the calibration constants in non-volatile memory.

Note 1: If CAL:INIT:STATE is '1', the module will automatically turn on as if an OUTP:STATE 1 command had been received. This will only occur during initial power up, *RST will only restore the saved CAL:INIT values. The unit will not automatically turn on, if enabled, after a *RST.

3.7 MEASURE SCPI COMMANDS

3.7.1 MEASURE SCPI COMMAND SUMMARY

```
MEASure[n]
:CURRent?
:POLARity?
:VOLTage?
:POWER?
```

3.7.2 MEASURE SCPI COMMAND REFERENCE

Command	Description
MEASure<n>	Measure subsystem. Module 'n'.
:CURRent?	Returns the floating point value of the DC output current in amps. The value will be negative if the polarity relay is in the INV state.
:POLARity?	Returns Polarity Relay setting.
:VOLTage?	Returns the floating point value of the DC output voltage in volts. The value will be negative if the polarity relay is in the INV state.
:POWER?	Returns the power in Watts that are delivered to the Load.

3.8 OUTPUT SCPI COMMANDS

3.8.1 OUTPUT SCPI COMMAND SUMMARY

```

OUTPut[n]
  :ISOLation <bool>
    :DEFault <bool>
    :DEFault?
  :ISOLation?
  :POLarity <NORM/0/OFF|INV/1/ON>
  :POLarity?
  :PROTection
    :DELAy <NRf>
    :DELAy?
    :FOLD <NRi>
    :FOLD?
  :SENSe <bool>
    :DEFault <bool>
    :DEFault?
  :SENSe?
  :STATe <bool>
  :STATe?
  :TRIPped?
  :MODFault <bool>
  :MODF?
    :CLEar <bool>
    :CLE?

```

3.8.2 OUTPUT SCPI COMMAND REFERENCE

Command	Description
OUTPut<n>	Output subsystem. Module 'n'.
:ISOLation <bool>	Turns on/off the output isolation relay. The output voltage must be set to zero prior to issuing this command. Valid arguments are 1/ON or 0/OFF.
:ISOLation?	Query the state of the isolation relay. 0 = open and 1 = closed.
:DEFault <bool>	Sets DEFault state of ISOL Relay, POR default state is ON. The ISOL/SENSe relays will be automatically sequenced during the STATE command.
:DEFault?	Query DEFault state of Isolation relay
:POLarity <NORM/0/OFF INV/1/ON>	Changes the state of the polarity relay. This command requires that the isolation/sense relays be opened beforehand. If the isolation relay is closed when this command is attempted, the state of the polarity relay will not change, and an error message will be generated. The default Polarity will be Normal with the Positive Output on Out 1.
:POLarity?	Query the state of the polarity relay.

:PROTection	
:DELAy <NRf>	Set Shutdown delay timer value, 0 to 40.95 Seconds
:DELAy?	Query Shutdown delay timer value
:FOLD <NRi>	Shutdown Mode, 0= Normal CC/CV mode operation. 1= Fault if Supply stays in Voltage mode. 2= Fault if Supply stays in Constant Current mode.
:FOLD?	Query Shutdown Mode setting.
:STATe <bool>	Closes the isolation/sense relays. Sets the output voltage and current to programmed values, turns on the supply. Valid arguments are 1/ON or 0/OFF. *RST state value is OFF. CAUTION: Ensure that suitable delays are incorporated to preclude hot switching of the isolation relay. See :DEFAult keyword entry for automatic relay operation..
:STATe?	Query the state of the unit. 1 means unit is on and 0 means unit is off
:SENSEe <bool>	Turns On/Off the output sense relay. The output voltage must be set to zero prior to issuing this command. Valid arguments are 1/ON or 0/OFF.
:SENSEe?	Query the state of output sense relay.
:DEFAult <bool>	Sets DEFAult state of ISOL Relay, POR default state is ON. The ISOL/SENSEe relays will be automatically sequenced during the STATE command.
:DEFAult?	Query DEFAult state of ISOL Relay.
:TRIPped?	Returns the integer value 1 (TRIPPED) or 0 (UNTRIPPED) state of the output.
:MODFAult <bool>	Set Module Trigger out, to assert Hi when a HW fault is detected. 0/OFF returns Trigger out to normal operation. Used for Fault Group operation.
:MODF?	Query the state of Module Fault Mode
:CLEAr <bool>	When in Module Fault mode, when 1/ON forces Trigger out to LOW to allow a Fault Group to be cleared.
:CLE?	Query if the state of the Module Fault output is forced LOW.

3.9 SOURCE SCPI COMMANDS

3.9.1 SOURCE SCPI COMMAND SUMMARY

```

SOURCE[n]
  :CURRENT <Nrf>
  :CURRENT?
    :LIMIT <Nrf>
    :LIMIT?
    :PROTECTION <Nrf>
    :PROTECTION?
      :TRACKING <bool>
      :TRACKING?
    :RAMP See Table 3-9. For Software Ramps
    :TRIGGER See Table 3-8. For Software Setpoints
  :VOLTAGE <Nrf>
  :VOLTAGE?
    :LIMIT <Nrf>
    :LIMIT?
    :PROTECTION <Nrf>
    :PROTECTION?
      :TRACKING <bool>
      :TRACKING?
      :ENABLE <bool>
      :ENABLE?
    :RAMP See Table 3-9. For Software Ramps
    :TRIGGER See Table 3-8. For Software Setpoints
  :UNDERVOLTAGE
    :PROTECTION <Nrf>
    :PROTECTION?
      :TRACKING <bool>
      :TRACKING?
      :TRIPPED?

```

3.9.2 SOURCE SCPI COMMAND REFERENCE

Command	Description
SOURCE<n>	Source subsystem. Module 'n'.
:CURRENT <Nrf>	Sets the output current in amps.
:CURRENT?	Query the set output current in amps.
:LIMIT <Nrf>	Sets an upper soft limit on the programmed output current for the supply.
:LIMIT?	Query an upper soft limit on the programmed output current for the supply.
:PROTECTION <Nrf>	Sets the overcurrent protection trip point in amps
:PROTECTION?	Query the overcurrent protection trip point in amps
:TRACKING <bool>	Set the over current protection to tracking. 1 means turn on the tracking supervisory and 0 means turn off the tracking supervisory
:TRACKING?	Query the tracking supervisory status.

Command	Description
:RAMP	See Table 3-9. For Software Ramps
:TRIGger	See Table 3-8. For Software Setpoints
:VOLTage <Nrf>	Sets the output voltage of the supply in volts. <i>*See note at end of this table.</i>
:VOLTage?	Query the set point of the output voltage of the supply in volts.
:LIMit <Nrf>	Sets the upper soft limit on the programmed output voltage.
:LIMit?	Query an upper soft limit on the programmed output voltage.
:PROTection <Nrf>	Sets the overvoltage protection trip point in volts.
:PROTection?	Query the set point of the overvoltage protection trip point in volts.
:TRACking <bool>	Set the over voltage protection to tracking. 1 means turn on the tracking supervisory and 0 means turn off the tracking supervisory
:TRACking?	Query the tracking supervisory status.
:ENABle <bool>	Disable OVP when OFF, Save current setting, and set OVP to factory maximum value. When ON, restore the saved OVP setting.
:ENABle?	Query if OVP is Enabled or Disabled.
:RAMP	See Table 3-9. For Software Ramps
:TRIGger	See Table 3-8. For Software Setpoints
:UNDERVOLTage	
:PROTection <Nrf>	Sets the undervoltage protection trip point in volts.
:PROTection?	Query the set point of the undervoltage protection trip point in volts.
:TRACking <bool>	Set under voltage protection tracking. 1 = On, 0= Off.
:TRACking?	Query the tracking supervisory status.
:TRIPped?	Returns 1 if the supply has an undervoltage fault

***Note:** Set and Query the state of the polarity relay using the `OUTPut<n>:POLarity` command.

3.10 INPUT SCPI COMMANDS

3.10.1 INPUT SCPI COMMAND SUMMARY

```
INPut<n>
    :MENABle <bool>
    :MENA?
```

3.10.2 INPUT SCPI COMMAND REFERENCE

Command	Description
INPut<n>	
:MENABle <bool>	1 = allow Module ENABle to re-start (turn on) the module, 0 = No.
:MENA?	Query the Module re-start status.

3.11 STATUS SCPI COMMANDS

3.11.1 STATUS SCPI COMMAND SUMMARY

```

STATUS[n]
:MODULE
    :ENABLES <0+NR1>
    :ENAB?
    :FAULTS?
    
```

3.11.2 STATUS SCPI COMMAND REFERENCE

Command	Description
STATUS<n>	Status subsystem. Module 'n'.
:MODULE	
:ENABLES<0+NR1>	Enable supervisory. See Table 3-3 for enable values.
:ENABLES?	Query the enabled supervisories
:FAULTS?	Query the module faults

Table 3-3. Fault and Enable Register

Bit	Hex Value	Mnemonic	Description
0	0x00000001	LDF	Line Drop Fault
1	0x00000002	RSF	Reverse Sense Fault
2	0x00000004	OCF	Over Current Fault
3	0x00000008	OVP	Over Voltage Protection Fault
4	0x00000010	ROCF	Redundant Over Current Protection Fault
5	0x00000020	ROVP	Redundant Over Voltage Protection Fault
6	0x00000040	UVP	Under Voltage Protection Fault
7	0x00000080		RESERVED
8	0x00000100	IMPTEMPHSK1	Heatsink1 Temperature is Warm
9	0x00000200	IMPTEMPHSK2	Heatsink2 Temperature is Warm
10	0x00000400	OVTEMPHSK1	Heatsink1 Temperature Exceeds Limit
11	0x00000800	OVTEMPHSK2	Heatsink2 Temperature Exceeds Limit
12	0x00001000	AFF	Air Flow Fault
13	0x00002000	UVP5V	Internal 5V Under Voltage Fault
14	0x00004000	OVP5V	5V Over Voltage Fault
15	0x00008000	UVPP12V	+12V Under Voltage Fault
16	0x00010000	OVPP12V	+12V Over Voltage Fault
17	0x00020000	UVPM12V	-12V Under Voltage Fault
18	0x00040000	OVPM12V	-12V Over Voltage Fault
19	0x00080000	GNDF	Ground Fault
20	0x00100000	OCLF	Outer Control Loop Fault
21	0x00200000	ICLF	Inner Control Loop Fault

Bit	Hex Value	Mnemonic	Description
22	0x00400000		RESERVED
23	0x00800000		RESERVED
24	0x01000000	PRIENA	Primary DC Bus Enable Fault
25	0x02000000	PRST	Power-on Reset Fault
26	0x04000000	GRPF	Group Fault
27	0x08000000	MDENA	Module Enable False (Does not activate Fault Led)
28	0x10000000	CNVF	Converter Fault
29	0x20000000	PAOC	Primary Average Overcurrent Fault (PAOC or AVG_TRP)
30	0x40000000	Analog Flt	Analog Fault
31	0x80000000		RESERVED

Note: Turning off Supervisory Enables can allow permanent and catastrophic damage to the Module to occur.

3.12 TRIGGER SCPI COMMANDS AND LISTS

The ReFlex Power system provides two programming mode available in the High Power and Low Power DC (HPDC and LPDC) modules: the List/Trigger mode and the Software Setpoint and Ramps mode.

The List/Trigger mode (Section 3.12.1) provides the ability to program accurate and tightly timed, externally-synchronized events ranging from simple, synchronized output changes to complex multiple-step, multi-module, externally and internally driven sequences (Lists), which can be driven by hardware trigger signals.

The Software Setpoint and Ramps mode (Section) provides the ability to program a software-triggered voltage and/or current setpoint change, and to ramp the supply output, with an execution latency of 10-20 mS.

3.12.1 LIST AND TRIGGER COMMAND OPERATION

This section describes first the Trigger architecture and behavior, then describes Lists and List/Trigger requirements. Each programmable High Power and Low Power DC power module has a module level trigger input and output signal as a part of its front panel control interface. The ReFlex Power™ Controller has four general-purpose I/O signals, which are bussed to all modules via high-speed backplane signals. Each can be programmed to control the module or have the module indicate its condition. This capability is extendable to grouped modules as well.

In addition to or in conjunction with these synchronizing features, the ReFlex Power™ module(s) can process a sequence (List) of pre-programmed commands, frequently driven by trigger signals, to control its output.

Figure 3-1 diagrams the various trigger ports and trigger architecture in the ReFlex Power™ system. Each module has a unique set of trigger in/out ports. These are termed the module ports and have the same address as the power module. There are

up to four bussed trigger ports that are shared by all modules. Each power module and the ReFlex Power™ Controller can access these signals to either send or to receive trigger signals. The limitation on the number of these signals is due to their also being used to support DC series groups and to create fault groups. Hence the sum of DC series groups, fault groups and allocated buss trigger signals must be less than or equal to four.

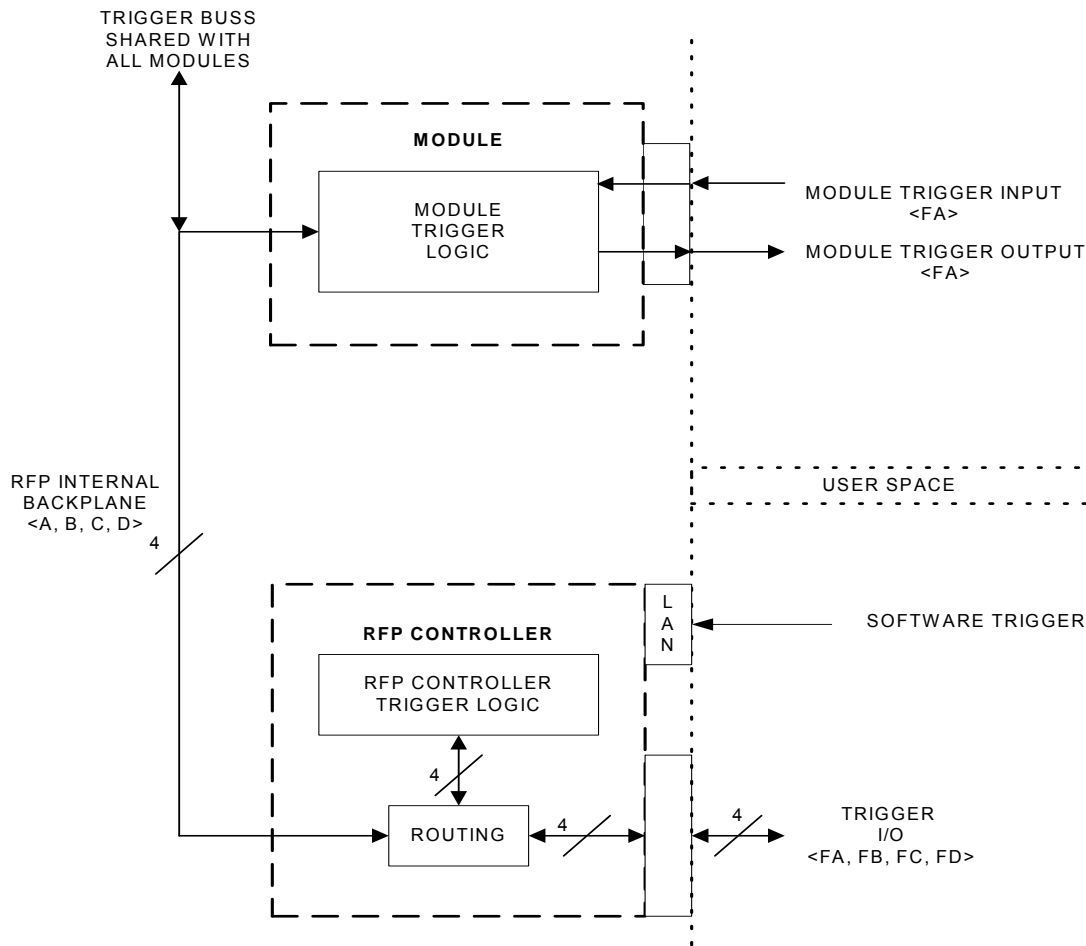

Figure 3-1. RFP Trigger Logic

EXTERNAL FRONT PANEL MODE TRIGGERING

Figure 3-2 outlines the basic features of the external mode trigger input operation. In this case, the trigger is sent to the power module that has been pre-programmed to respond in a particular fashion, such as setting an output voltage level.

This is also the simplest mode as after setting up the condition, (shown as the external arming event) the module simply waits for the trigger to be received and then proceeds to set the output to previously established value(s) possibly after a delay

time. The external arming event encompasses the receipt of a command sequence needed to setup the module prior to trigger receipt.

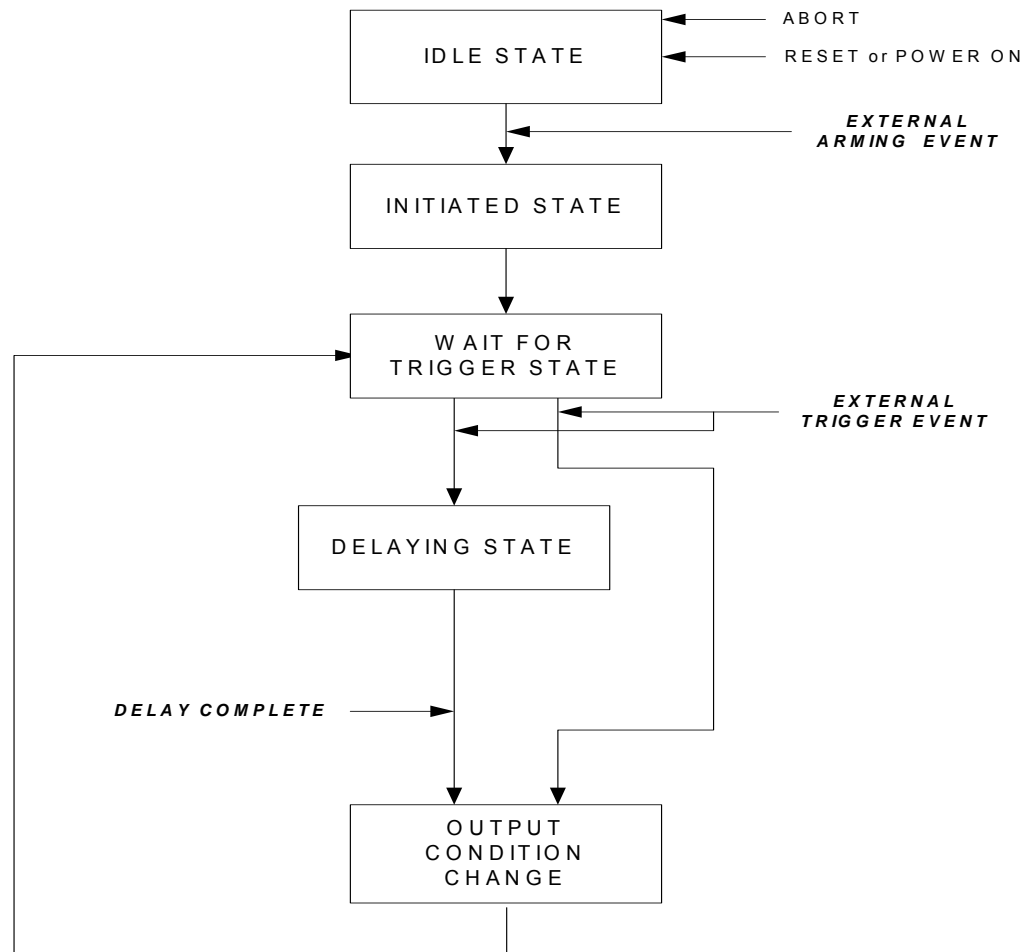

Figure 3-2. Fixed Mode Trigger Input

Each power module’s trigger interface can be routed as a local signal used only by the power module or can be connected to the buss trigger set by SCPI command. When externally commanded, the ReFlex Power Controller establishes this allocation and sends the power module the sequence of trigger routing commands. The default is to have the power module’s triggers signals all local to the module. The Module’s front panel trigger input and output are separate and distinct; they are always available for internal usage.

Figure 3-3 shows the signal routing from the trigger signal received by the power module to the switch, (diagrammatic representation only). When the switch is closed,

opposite to that shown, then the received trigger is routed to the backplane trigger buss.

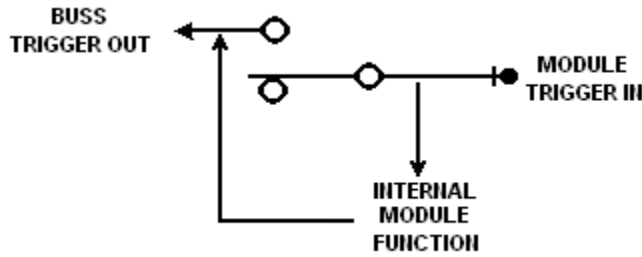

Figure 3-3. Module/Buss Trigger Input

Figure 3-4 shows the signal routing for trigger transmitted from the power module, which is out of power modules front panel connector. If the switch is closed, opposite to the position shown, the backplane buss signal is also routed to the modules front panel connector. Note in both cases, the module can receive the trigger buss signal.

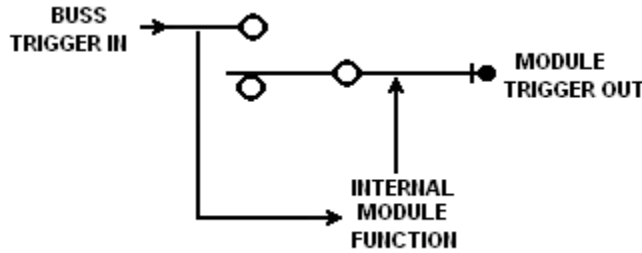

Figure 3-4. Module/Buss Trigger Out

Table 3-4 lists the SCPI commands associated with routing of the trigger signals. Note this command assumes that buss trigger resources are available, if it is not the ReFlex Power™ Controller will respond with a message that the trigger cannot be allocated.

'<t>' is the Trigger signal specifier. All modules can use the simplex Inter-module Trigger Buss; these signals are designated 'a' through 'd'. The ReFlex Power™ Controller has four simplex Front Panel trigger signals, designated 'fa', 'fb', 'fc', 'fd'. For all other Modules, 'fa' designates its own full duplex Front Panel trigger, which does not need to be configured as an IN/OUT, it does need to be configured with the TRIG:SLOPe commands.

SCPI Command	Description
TRIGger<n>:INP <t>	Establish that on module n, trigger t is an input. t = a-d, fa (sets switch open)
TRIGger<n>:OUTP <t>	Establish that on module n, trigger t is an output. t = a-d, fa (sets switch open)
TRIG<n>:INP <t>, OUTP <t> TRIG<n>:OUTP <t>, INP <t>	n = Module number. The RFP's GPIO Buss signals (t = a, b, c, or d) connected to 'fa', the Modules Front Panel trigger, specifying direction. The trigger signal is passed through the Module. (switch closed)
TRIG:INP <t>, OUTP <t> TRIG:OUTP <t>, INP <t>	Map RFPC's GPIO Buss signals (t = a, b, c, or d) to Front Panel triggers (t = fa, fb, fc ,fd), specifying direction. (switch closed)
TRIG<n>:DISPlay?	Displays the module's usage of the GPIO Buss signals.
TRIG:DISPlay?	Displays a list of the module numbers that use the GPIO Buss signals.
TRIG<t>:ENABle ¹	RFPC (t = fa, fb, fc ,fd), trigger enable
TRIG<t>:DISABle ¹	RFPC (t = fa, fb, fc ,fd), trigger disable

Table 3-4. SCPI for Module Trigger Routing

NOTE: At this time the ReFlex Power™ Controller only implements direct trigger mapping 'a' to 'fa', 'b' to 'fb'...

¹ Allow a signal to pass/not pass through the trigger channel specified. (Output enable).

TRIGGER SIGNALS

Trigger signals can be any one of three types:

- Positive leading edge assertion
- Negative leading edge assertion
- Dual edge

Each of these has specific point(s) at which triggering occurs. All three trigger types can be input or output, and are established by SCPI commands. The positive edge trigger assertion is used for the example figures herein though any of the allowed trigger types can be used.

The positive and negative edge triggers should be familiar but the dual edge trigger may not be as obvious. The trigger input is not analog, it is digital and follows the levels that are listed within this section. If the quiescent state is low then the trigger occurs when the signal transitions to the high state. This is shown as a slow ramp up of the trigger signal, (in fact the ramp time is typically very rapid). When the trigger signal passes through about 3.2 V the trigger is asserted. The next trigger occurs when the signal transits back down to about 1.3 V where upon the next trigger is asserted. This is termed de-assertion for differentiation but in fact it is just the next trigger event.

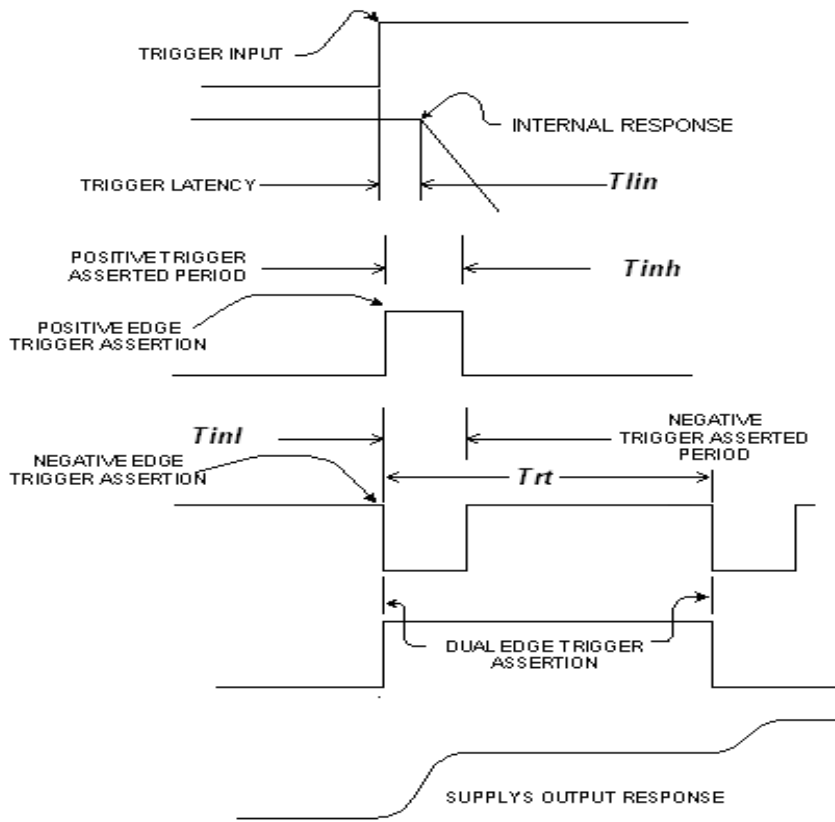

Figure 3-5. Trigger Signal Types

Table 3-5 provides the detailed input trigger signal specifications for the various states.

Trigger	Range ² (Volts)	Low Level (Volts)	High Level (Volts)	Timing (Microseconds)
Input Voltage and Current ¹	+16.5 to -5	$V_{il} \leq 1.35 @ 1\text{mA}$	$V_{ih} \geq 3.15 @ 1\text{mA}$	
Trigger Latency ³				$T_{lin} \leq 5$
Positive Assertion				$T_{inh} \geq 2$
Negative Assertion Period				$T_{ini} \geq 2$
Trigger Recovery Time				$T_{rt} \geq T_{inx} \text{ or } T_{rt} > 50$

Table 3-5. Input Trigger Signal Specifications

¹ Typical high-level leakage current is 1.15 mA @ 16.5V DC.
² All voltages are with respect to the associated return signal.
³ Trigger latency is the maximum time from trigger receipt to when the response begins.

Figure 3-6 and Table 3-6 specify the trigger out signals.

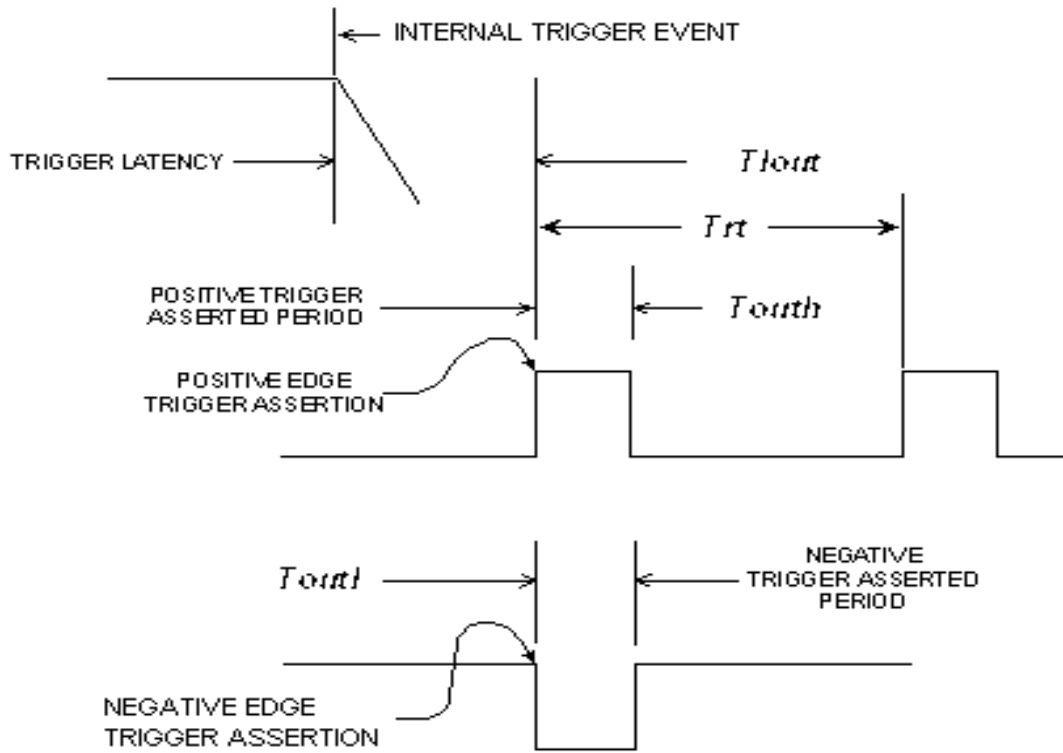

Figure 3-6. Output Trigger Timing

Trigger	Range ² (Volts)	Low Level ³ (Volts)	High Level (Volts)	Timing (Microseconds)
Output Voltage and Current ¹	+5.5 V to -0.7V	$V_{ol} \leq 0.3V @ 1mA$	$V_{oh} \geq 4.13 @ 1mA$	
Trigger Latency ⁴				$T_{lout} \leq 5$
Positive Assertion Period				$T_{outh} \geq 2$
Negative Assertion Period				$T_{outl} \geq 2$
Trigger Recovery Time				$T_{rt} > T_{outx} + 4$

Table 3-6. Output Trigger Specifications

- ¹ Typical high-level leakage current is 0.01 mA @ 5.5V DC.
- ² All voltages are with respect to the associated return signal.
- ³ Maximum low-level sink current is 7 mA.
- ⁴ Trigger latency is the maximum time from selected event to when the trigger is issued.

TRIGGER INPUT RESPONSES

The operation surrounding the response due to the receipt of a trigger by a power

module is shown in the next figure. The trigger condition can be based on establishing either voltage or current settings. Actually, both voltage and current can be set due to a single trigger receipt.

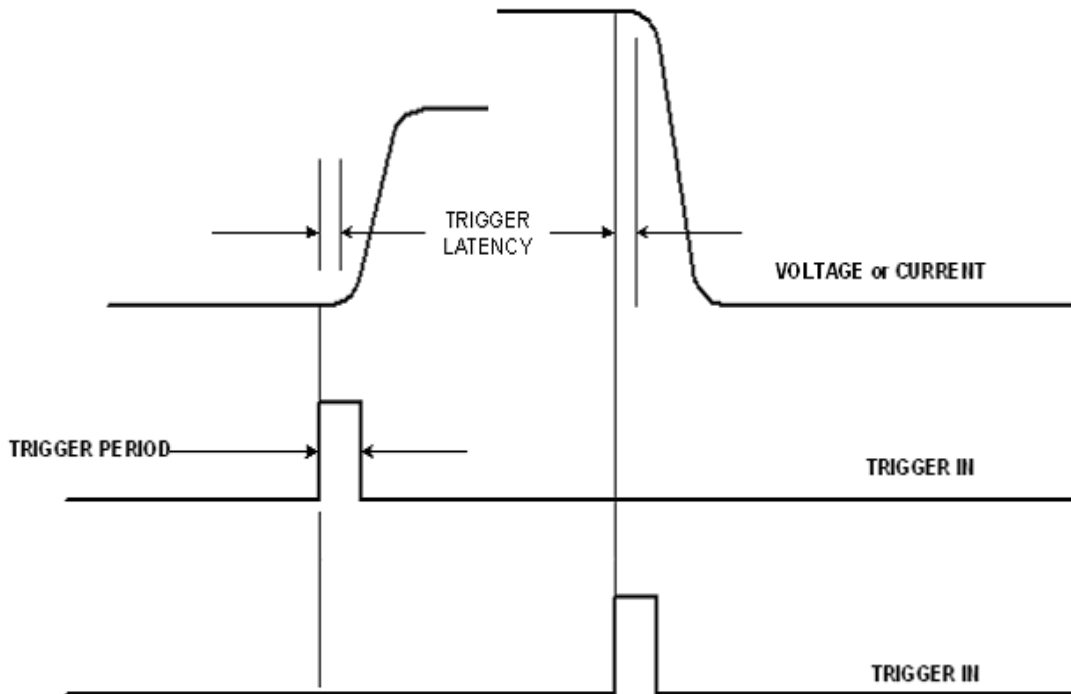

Figure 3-7. Trigger Input Responses

LIST MODE TRIGGERS

List mode triggering is more complex in that its function is to create complex operational sequences (Lists) that are timed precisely with respect to an external trigger or internal event. That is, either trigger or an event can initiate a sequence. The following figure outlines the logic flow of trigger driven list processing.

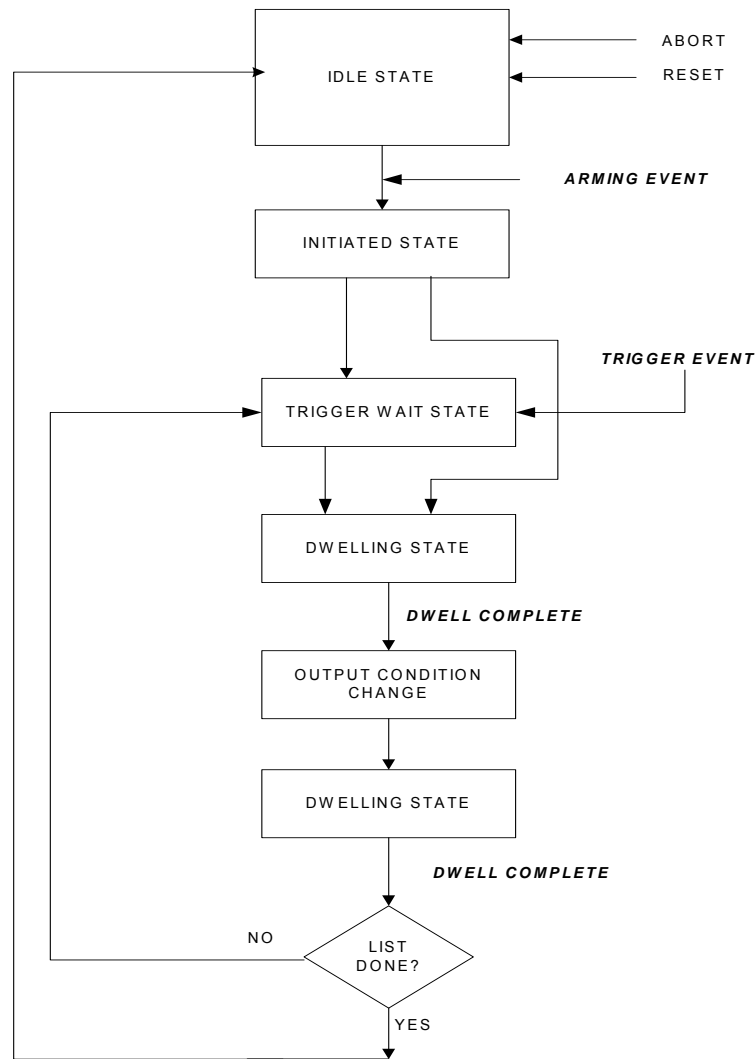

Figure 3-8. List Mode Logic

Information and requirements for the LIST commands include:

- The maximum size allowed for a single list is 2046 entries.
- Each SCPI command may translate to 1 or as many as 10 entries depending on the command.
- The current size of a list can be queried during LIST creation by using the LIST<n>:TAG? command.
- Lists can be saved in non-volatile memory and recalled by using the name of the list.

- When a LIST is being created in a module, the module is placed in a special mode. This mode inhibits actual relay operation, to minimize any chance of energizing an external load.
- The output relays are inhibited from closing on STATE ON commands, and RAMP commands go from start point to endpoint with no delay.
- Trigger output, WAIT and DWELL commands are not executed.
- Any triggers that are received during a LIST:RAMP or LIST:DWELL command are ignored.
- Setpoint commands are executed.
- All query commands except actual relay states and MEAS:CURR are fully functional.
- During the execution of a LIST, only query commands are accepted.
- During LIST creation, non-LIST commands may interact with the LIST to generate commands to automatically control the supply.
- If Tracking is ON, (OVP, OCP, UVP) their setting changes will automatically be included in the LIST commands for simple setpoint changes.
- The RAMP commands do NOT function in tracking modes, and will generate errors if attempted when any tracking mode is on. Tracking modes must be turned off and OVP, OCP, and UVP set to proper values for the specific RAMP command, else faults may occur. After the RAMP command and new setpoints have been issued, tracking may be then turned back on.
- In List mode, all relay operation should always be coordinated with the STATE command by using the OUTP:ISOL/SENSE:DEF commands.
- <filename> is case sensitive; double quoted string, maximum 29 characters in length, no path/file extension is allowed.

There may be additional commands added as the product is applied. The non-LIST commands that interact with LISTS during creation are:

```

OUTP<n>:ISOL:DEF <bool>
OUTP<n>:SENSE:DEF <bool>
OUTP<n>:STATE <bool>
OUTP<n>:POL <bool>
SOUR<n>:CURR <Nrf+>
SOUR<n>:CURR:PROT <Nrf+>
SOUR<n>:CURR:PROT:TRACK <bool>
SOUR<n>:VOLT <Nrf+>
SOUR<n>:VOLT:PROT <Nrf+>
SOUR<n>:VOLT:PROT:TRACK <bool>
SOUR<n>:UNDERVOLT:PROT <Nrf+>
SOUR<n>:UNDERVOLT:PROT:TRACK <bool>
TRIG<n>:TRIG <t>
TRIG<n>:INP <t>, OUTP <t>
TRIG<n>:OUTP <t>, INP <t>
TRIG<n>:INP <t>

```

```
TRIG<n>:OUTP <t>
TRIG<n>:INPut:SLOPe [POSitive | NEGative | BOTH | NONE]
TRIG<n>:OUTput:SLOPe [POSitive | NEGative | BOTH]
TRIG<n>:WIDTh <NRF+>
```

See Section 3.15 for a summary and description of the LIST commands.

MODULE OPERATION IN LIST CREATION MODE

When a LIST is being created in a module, the module is placed in a special mode. This mode inhibits actual relay operation, to minimize any chance of energizing an external load. The output relays are inhibited from closing on STATE ON commands.

RAMP commands go from start point to endpoint with no delay. Trigger output, WAIT's and DWELL's are not executed. Setpoint commands are executed. All query commands except actual relay states and MEAS:CURR are fully functional.

During the execution of a LIST, only query commands are acceptable; setpoint commands may generate errors or cause improper LIST execution.

LIST TRIGGER GROUPS

All ReFlex Power™ high power and low power DC power modules can be programmed to respond to the common trigger buss. The response to the trigger or triggers allows a complex cross module type tightly timed sequence to result. All this on a single module basis there is little new, the novel part is to establish a trigger sequence that crosses several modules.

One new concept is to assign one or more power modules one or more trigger pulses from a pulse sequence. If the pulse sequence is very tightly timed and well described, the result is a complex well-timed sequence of events. The following figure and associated table describes this concept.

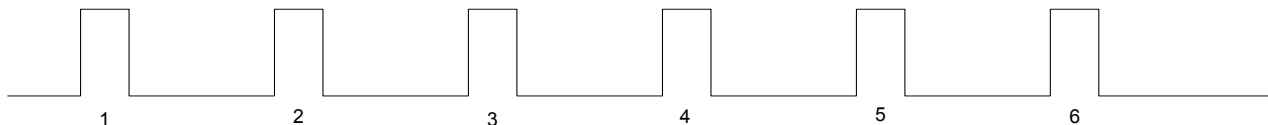

Figure 3-9. Group Pulse Sequence

Pulse	Module	Function
1	DC1	DCV1 output to 5 V
2	DC1 and DC2	DCV1 to 10V and DCV2 to 5V
3	DC2	IDC2 to 1.2A and 5.5 volts
4	DC1, DC2	All outputs off
5	DC3	DCV3 to 12V and 2.0A
6	DC3	DC3 off

Table 3-7. Group Pulse Function

The following section provides various List and Trigger examples for synchronizing multiple modules.

LIST MODE EXAMPLES

1. **Generate a 1 Volt saw tooth waveform on a 12 volt output to simulate AC rectification ripple for 2.5 seconds.**

```
...
LIST2:LABEL3
LIST2:RAMP:VOLT 13.0, 12.0, 8.33333e-3
LIST2:LOOP 299, LABEL3
...
```

2. **Trigger example: synchronize multiple Modules, 1 & 4.**

```
LIST1:START "TRIGTEST" // start LIST on module 1
TRIG1:INP A           // set backplane line A as trigger input
SOUR1:VOLT 0.0        // set initial voltage to 0
SOUR1:CURR 1.0        // set current
OUTP1:STAT 1         // turn supply on
LIST1:LABEL0          // label allows the segment to be repeatable
LIST1:TRIG A, WAIT    // wait for 1st trigger
SOUR1:VOLT 15.0       // program voltage
LIST1:TRIG A, WAIT    // wait for 2nd trigger
LIST1:TRIG A, WAIT    // wait for 3rd trigger
LIST1:TRIG A, WAIT    // wait for 4th trigger
SOUR1:VOLT 0.0        // program voltage to 0
LIST1:LOOP 1, LABEL0 // loop once to repeat the sequence
OUTP1:STAT 0         // turn off supply
LIST1:END             // end the LIST
LIST1:STORE           // store the list

LIST4:START "TRIGTEST" // start LIST on module 4
TRIG4:INP A           // set backplane line A as trigger input
SOUR4:VOLT 0.0        // set initial voltage to 0
SOUR4:CURR 5.0        // set current
OUTP4:STAT 1         // turn supply on
LIST4:LABEL0          // label allows the segment to be repeatable
LIST4:TRIG A, WAIT    // wait for 1st trigger
LIST4:TRIG A, WAIT    // wait for 2nd trigger
SOUR4:VOLT 5.0        // program voltage
LIST4:TRIG A, WAIT    // wait for 3rd trigger
SOUR4:VOLT 0.0        // program voltage to 0
```

```

LIST4:TRIG A, WAIT           // wait for 4th trigger
LIST4:LOOP 1, LABEL0 // loop once to repeat the sequence
OUTP4:STAT 0                // turn off supply
LIST4:END                   // end the LIST
LIST4:STORE                 // store the list

```

Setup the RFPC to transfer external trigger onto backplane trigger channel A.

```

TRIG:INP FA, OUTP A // set trigger channel IN to FA, OUT to backplane A
TRIGFA:SLOPE POS // trigger FA response to rising edge active high
TRIGFA:ENAB // enable RFPC channels FA and A

```

To execute the sequence issue the following commands:

```

LIST1,4:OPEN "TRIGTEST" // loads "TRIGTEST" on Modules 1 & 4.
LIST1,4:ARM // this starts the LIST executing, which will
              then execute the wait for trigger.

```

To cause the RFPC itself to generate a backplane trigger

```

TRIG:TRIG FA // Generate a hardware trigger internally

```

When you are done with LIST/TRIG operations

```

LIST1,4:CLOSE // this disables LIST processing on the DC modules
TRIGFA:SLOPE NONE // tears down the RFPC trigger setup

```

3.13 SOFTWARE TRIGGERED SETPOINTS AND RAMPS

Software Setpoints and Ramps is a simple way of controlling a single module to generate a software triggered setpoint change, or ramp the supply output.

3.13.1 VOLT AND CURRENT SOFTWARE SETPOINTS COMMAND SUMMARY

```

SOURCE<n>
  :VOLTage
    :TRIGger <NRf>
    :TRIGger?
  :CURRent
    :TRIGger <NRf>
    :TRIGger?
TRIGger<n>
  :TYPE <NRi>

```

Source Trigger commands allow a voltage and/or current setpoint to be delayed for later application. The trigger latency is on the order of 10-20 mS. If multiple voltage or current commands are received, the earlier ones of each type will be overwritten, without error. These setpoints are not retriggerable.

Setpoints	Description
SOUR<n>:VOLT:TRIG <NRf>	Setup for a deferred SOUR<n>:VOLT <NRf> command
SOUR<n>:VOLT:TRIG ?	Query returns pending Voltage setting, -0.0 if inactive
SOUR<n>:CURR:TRIG <NRf>	Setup for a deferred SOUR<n>: CURR <NRf> command
SOUR<n>:CURR:TRIG ?	Query returns pending Current setting, -0.0 if inactive
TRIG<n>:TYPe <NRi>	0 = VOLT, 1 = CURR, 2 = Both, Apply the setpoints

Table 3-8. Software Triggered Setpoints

3.13.2 VOLTAGE AND CURRENT SOFTWARE RAMPS COMMAND SUMMARY

```

SOURCE<n>
  :VOLTage
    :RAMP <NRf> , <NRf> , <NRf>
  :CURRent
    :RAMP <NRf> , <NRf> , <NRf>
  :VOLTCURR
    :RAMP <NRf> , <NRf> , <NRf> , <NRf>
SOURCE<n>
  :VOLTage
    :RAMP
      :TRIGger <NRf> , <NRf> , <NRf>
      :TRIGger?
  :CURRent
    :RAMP
      :TRIGger <NRf> , <NRf> , <NRf>
      :TRIGger?
  :VOLTCURR
    :RAMP
      :TRIGger <NRf> , <NRf> , <NRf> , <NRf>
      :TRIGger?
TRIGger<n>
  :TYPe 3
  :ABORt
    
```

Voltage and Current ramps can be setup and invoked on a software basis, these commands use the same hardware that is used for LIST/TRIGGER functions, so these functions cannot be used or intermixed at the same time. Issue a LIST<n>:CLOSE command to reset the LIST/TRIGGER subsystem when usage of these commands is done.

The following table explains the parameters that are required for the RAMP commands and functionality. The warning about tracking modes also applies.

The SOUR:...:RAMP command come in two types: immediate and delayed (software TRIGgered), The duration of a RAMP is accurately timed, if the ramp start time must be tightly controlled to an external event, use LIST/TRIGGER processing. If multiple ramp trigger commands of any type are received, the earlier ones will be overwritten, without error. The delayed command type is not re-triggerable.

Command	Description
SOUR<n>:VOLT:RAMP fVstart, fVend, fTSec	Start an immediate voltage ramp.
SOUR<n>:CURR:RAMP fIstart, fIend, fTSec	Start an immediate current ramp.
SOUR<n>:VOLTCURR:RAMP fVstart, fVend, fIstart, fIend, fTSec	Start an immediate voltage and current ramp, changing both voltage and current
SOUR<n>:VOLT:RAMP:TRIG fVstart, fVend, fTSec	Setup a voltage ramp, and then execute it when triggered
SOUR<n>:VOLT:RAMP:TRIG?	Query ramp parameters, Zero are returned if inactive.
SOUR<n>:CURR:RAMP:TRIG fIstart, fIend, fTSec	Setup a current ramp, and then execute it when triggered
SOUR<n>:CURR:RAMP:TRIG?	Query ramp parameters, Zeros are returned if inactive.
SOUR<n>:VOLTCURR:RAMP: TRIG fVstart, fVend, fIstart, fIend, fTSec	Setup a voltage and current ramp, and then execute it when triggered
SOUR<n>:VOLTCURR:RAMP:TRIG?	Query ramp parameters, Zeros are returned if inactive.
TRIG<n>:TYPE <NRi>	3= Execute the last loaded triggered ramp.
TRIG<n>:ABORT	Terminate a ramp in progress.
*OPC<n>?	0= Module Busy, executing a Command, LIST or RAMP. 1= IDLE, Command, List, or Ramp has finished execution.

Table 3-9. Software Ramps

3.14 TRIGGER SCPI COMMANDS

The SCPI commands associated with establishing external trigger signals are listed in this section.

3.14.1 TRIGGER SCPI COMMAND SUMMARY

```

TRIGger<n>
  :DISPlay?
  :INP <t>
  :OUTP <t>
  :INP <t>, OUTP <t>
  :OUTP <t>, INP <t>
  :INPut:SLOPe [POSitive | NEGative | BOTH | NONE1]
  :OUTPut:SLOPe [POSitive | NEGative | BOTH]
  :TRIG <t>
  :WIDTh<NRf+>

```

3.14.2 TRIGGER SCPI COMMAND REFERENCE

Command	Description
TRIGger<n>	Trigger subsystem. <n> = module number.
:DISPlay?	Displays the module's usage of the GPIO Buss signals, that are used in the currently loaded List. See LIST below.
:INP <t>	Establish that on module n, trigger t is an input. t = a-d, fa (front panel only, in the DC module). (Non-pass through mode.)
:OUTP <t>	Establish that on module n, trigger t is an output. t = a-d, fa. (Non-pass through mode.)
:INP <t>, OUTP <t> :OUTP <t>, INP <t>	The RFP's GPIO Buss signals (t = a, b, c, or d) connected to 'fa', the Modules Front Panel trigger, specifying direction. The trigger signal is passed through the Module.
:INPut:SLOPe [POSitive NEGative BOTH NONE ¹]	Sets module n's fa trigger input edge as positive, negative, or both.
:OUTPut:SLOPe [POSitive NEGative BOTH]	Sets module n's fa trigger output edge as positive, negative, or both.
:TRIG<t> ²	Generate a trigger from module n, t = a-d, fa.
:WIDTh<NRf+>	n = Module number, sets Front Panel trigger output pulse width in SLOPE POS / NEG mode. The WIDTh timing range is 2.0e-6 to 2.097 seconds.

Note: At this time the ReFlex Power™ system only implements direct trigger mapping 'a' to 'fa', 'b' to 'fb', 'c' to 'fc' and 'd' to 'fd.'

¹ The TRIG:SLOPe NONE parameter disables the trigger and disconnects the 'fx' to 'x' connection.

² The POSitive and NEGative trigger pulse's on the Front Panel trigger output are not retriggerable, if a trigger pulse is being produced, and another trigger out is executed, it will be ignored, and no errors will be posted.

3.15 LIST SCPI COMMANDS

Please see Section 3.12.1 for background and proper use of the List commands.

3.15.1 LIST SCPI COMMAND SUMMARY

```
LIST<n>
:START "filename"
:END
:STORe
:DELETE "filename"
:CATalog?
:ABORT
:OPEN "filename"
:CLOSE
:ARM
:TAG <NRi>
:TAG?
:STATUS?
:ERRor?
:LABEL<0-31>
:GOTO LABEL<0-31>
:LOOP <NRi+>, LABEL<0-31>
:DWELL <NRf+>
:TRIGger <t>, WAIT
:RAMP
    :CURR fIstart, fIend, ftSec
    :VOLT fVstart, fVend, ftSec
    :VOLTCURR fVstart, fVend, fIstart, fIend, ftSec
:CURR GE fval, LABEL<0-31>
:CURR LT fval, LABEL<0-31>
:VOLT GE fval, LABEL<0-31>
:VOLT LT fval, LABEL<0-31>
```

3.15.2 LIST SCPI COMMAND REFERENCE

Command	Description
LIST<n>	LIST subsystem.
:START <filename> ¹	Names the list in module n with <filename>. This must be the first SCPI command in the LIST sequence
:END	Ends the list that was started by the LIST<n>:START <filename> command.
:STORe	Save the list as <filename>, overwrite is allowed.
:DELETE <filename> ¹	Deletes the saved list <filename>
:CATalog?	Returns the LISTS currently saved in module <n>.
:ABORT	Stops a LIST operation, returns to the IDLE state.

Command	Description
:OPEN <filename> ¹	Enables the saved list <filename> in module<n> for execution. This LIST can only be run; editing must be done in user space.
:CLOSe	Opposite of LIST:OPEN, disables the currently open list. Clears the LIST<n>:ERR? and LIST<n>:STATUS? error responses.
:ARM	Start module <n> executing the list upon receipt of this command.
:TAG <NRi>	Creates a user querable numeric marker in the LIST during list execution. NRi = 1-1023.
:TAG? ²	Returns the last encountered numeric marker that has been "executed" in the list. Used to track where module <n> is in the list sequence, during execution. During List creation, returns memory usage, up to 2040 instruction index units are allowed.
:STATUS?	Returns Script status of EXEC, IDLE, or STOP/FAULT.
:ERRor?	Returns: Status, Errors, Tag, & Instruction Index.
:LABEL<0-31>	32 Labels can be defined. Forward and backward LABEL references are allowed.
:GOTO LABEL<0-31>	GOTO LABEL<0-31>; List execution immediately continues at the referenced label.
:LOOP <+NRi>, LABEL<0-31>	Jump <NRi+> times to LABEL<0-31>. Used to repeat a sequence of events. Repeat count +NRi is 1 to 1677215.
:CURR GE fval, LABEL<0-31>	Branch to LABEL<n> if the output current is ≥ to fval.
:CURR LT fval, LABEL<0-31>	Branch to LABEL<n> if the output current is < fval.
:VOLT GE fval, LABEL<0-31>	Branch to LABEL<n> if the output voltage is ≥ to fval.
:VOLT LT fval, LABEL<0-31>	Branch to LABEL<n> if the output voltage is < fval.
:DWELL <NRf+>	Sets the dwell time, the period that LIST execution pauses, in module <n> for NRf+ seconds. 1.0e-6 ≤ NRf+ ≤ 2147.48 seconds.
:TRIGger <t>, WAIT	Module <n> waits for a trigger, <t> = a, b, c, or d, for Buss trigger in's, or fa to wait on the module's Front Panel trigger in.
Tracking MUST be OFF during RAMPs	
:RAMP	Ramp Generation
:CURR fIstart, fIend, ftSec	Generate a CURRent RAMP from fIstart, to fIend Amps, in ftSec Seconds. Note: Full scale excursions take about 100mS, and are load dependent, smaller current excursions are proportional.
:VOLT fVstart, fVend, ftSec	Generate a VOLTage RAMP from fVstart, to fVend Volts, in ftSec seconds. Note: Full scale excursions take about 20mS depending on type of load, smaller voltage excursions are proportional.
:VOLTCURR fVstart, fVend, fIstart, fIend, ftSec	Generate a VOLTage and CURRent RAMP from fVstart to fVend Volts, and from fIstart, to fIend Amps, in ftSec seconds.

¹ <filename> is case sensitive; a double quoted string, maximum 29 characters in length, no path/file extension is allowed.

NOTE: ftSec is 0.1mS to 2147.48 seconds. (35.791 minutes)

Any triggers that occur during a RAMP or DWELL command are ignored.

In List mode, all relay operation should always be coordinated with the STATE command by using the OUTP:ISOL/SENSE:DEfault commands.

If Tracking is ON, (OVP, OCP, UVP) their setting changes will automatically be included in the LIST commands for simple setpoint changes.

The Tracking modes do NOT function in RAMP functions, and faults may be generated. Tracking modes must be turned off and OVP, OCP, and UVP set to proper values for the specific RAMP command, else faults may occur. After the RAMP command has completed, and new setpoints issued, Tracking may be then turned back on.

² The average List/SCPI command that is compiled into a List executable takes from 1 to 4 instruction index units, and complex SCPI commands such as STATE 1, takes 16 instruction index units, because of relay, module power on, and setpoint sequencing. A voltage ramp takes 3 instruction index units. A STATE 0 command takes 7 units.

3.16 DC SYSTEM SCPI COMMANDS

3.16.1 DC SYSTEM SCPI COMMAND SUMMARY

```

SYSTEM
  :ERRor?
  :VERsion?
  :GROup
    :CATalog
      :PARallel?
      :SERies?
    :DEFine
      :PARallel <NR1>,.....,<NR1>
      :SERies <NR1>,.....,<NR1>
  :DELete <NR1>
  :DELETE:ALL
    
```

3.16.2 SYSTEM SCPI COMMAND REFERENCE

Command	Description
SYSTEM	System subsystem.
:ERRor?	Queries a 10 element Error Queue, for next error/event entry (first in, first out). Entries contain an error number and descriptive text. A return value of 0 indicates no error occurred; negative numbers are reserved by SCPI. The maximum return string length is 255 characters. All entries are cleared by the *CLS command.
:VERsion?	Returns the SCPI version that the instrument complies with.
:GROup	Group subsystem
:CATalog	Displays list of defined groups in the system.
:PARallel?	Returns the master address 1000+N1 followed by the modules N1,N2...Nn that make up the parallel group.
:SERies?	Returns the master address 2000+N1 followed by the modules N1,N2...Nn that make up the series group.
:DEFine	Creates a group of the specified type
:PARallel <n>,<n>, ...	Sets the modules to be paralleled. Because only like modules can be paralleled valid inputs are <2>, <5>, <7>, etc. The lowest number in the argument list is the address of the parallel-master module and the rest of the numbers are the address's of the parallel-slave modules. In a parallel configuration, only the Master module, 1002, will process SCPI setpoint commands properly. The voltage and current set points for the parallel group will be set to zero, normal polarity, and the output relays will be open. For defaults, see CAL:INIT:xxx commands.
:SERies <n>,<n>, ...	Sets the specified modules into the series group. Because only like modules can be connected in series, valid inputs are <1002>, <1004>, etc. The lowest number in the argument list is the module address of the series-master module and the others are the address's of the series-slave modules. In a series configuration, only the Master module, 2002, will process SCPI setpoint commands properly. The voltage and current set points for the parallel group will be set to zero, normal polarity, and the output relays will open. For defaults, see CAL:INIT:xx commands.

Command	Description
:DELeTe <n>	Deletes the specified group. NR1 is 1021 for the parallel group that has the parallel-master module address of 21. <n> is 2003 for the series group that has the series-master module address of 3.
:DELeTe:ALL	Deletes any and all the groups in the RFP system

3.17 EXAMPLES OF USING THE SCPI COMMANDS

The following examples demonstrate programming a module to control and to readback the output using the SCPI commands. The maximum voltage and current output is dependent on the particular model. The examples list only the SCPI commands; the code required to send the commands is dependent on the type of language you are using (e.g., C or BASIC) and hardware.

EXAMPLE: Program a module with no load at the output to 5 VDC @ 1A, and verify the output.

```
// Use SYST:ERR? after each command to verify no programming errors.
// turn on the unit.
*CLS // clear the unit to its power-on default settings.
*RST // reset the unit.
OUTP<n>:ISOL 1 // set isolation relay closed
OUTP<n>:SENS 1 // set sense relay closed
OUTP<n>:STAT 1 // close output relay
SOUR<n>:CURR 1.0 // program output current to 1.0 A.
SOUR<n>:CURR? // confirm the output current setting (response: 1.0).
SOUR<n>:VOLT 5.0 // program output voltage to 5.0 VDC.
SOUR<n>:VOLT? // confirm the output voltage setting (response: 5.0).
MEAS<n>:CURR? // measure the actual output current (response: ~ 0.0 with no load on output).
MEAS<n>:VOLT? // measure the actual output voltage (response: ~ 5.0).
```

EXAMPLE: Program a DC power supply (with no load at the output) to generate a Fault upon an overvoltage protection trip condition.

```
// Use SYST:ERR? after each command to verify no programming errors.
// Turn on the unit.
*CLS // clear the error queue.
*RST // reset the unit.
OUTP<n>:STAT 1 // close output relay
SOUR<n>:VOLT:PROT 12.5 // program the OVP trip point to 12.5 VDC.
SOUR<n>:VOLT:PROT? // confirm the OVP trip point setting (response: 12.5).
SOUR<n>:CURR 1.0 // program output current to 1.0 A.
SOUR<n>:VOLT 12.0 // program output voltage to 12.0 VDC.
SOUR<n>:VOLT 13.0 // program output voltage to 13.0 VDC - cause OVP trip!
// use the OUTP<n>:STAT? query to confirm that the unit faulted
// off, and use the STAT<n>:MOD:FAUL? query to confirm which
// fault.
```

EXAMPLE: Program a DC power supply (with no load at the output) to change its output voltage and current to 5 VDC @ 1A at the same time.

// Use SYST:ERR? after each command to verify no programming errors.

```
*CLS // clear the error queue.
*RST // reset the unit.
SOUR<n>:CURR 1 // program output current to 1.0 A.
SOUR<n>:VOLT 5 // program output voltage to 5.0 VDC.
OUTP<n>:STAT 1 // turn on the supply
MEAS<n>:VOLT? // measure the actual output voltage (response: ~ 5. 0 depending on
                timing).
MEAS<n>:CURR? // measure the actual output current (response: ~ 0. 0 with no load on
                output).
MEAS<n>:VOLT? // measure the actual output voltage (response: 5.0).
```

EXAMPLE: Program DC power supply 32V Modules Channels 3, 4, & 5 for parallel operation, 10VDC, and 75A.

// Use SYST:ERR? after each command to verify no programming errors.

// turn on the unit.

```
*CLS // clear error queue.
*RST // reset modules.
SYST:GRO:DEF:PAR 3,4,5 // parallel modules 3,4,5. Channel 3 is the master.
SOUR1003:CURR 75 // set current to 75A
SOUR1003:VOLT 10 // set voltage to 10V
OUTP1003:STAT 1 // close output relays, and turn the supply on.
MEAS1003:VOLT? // measure output voltage
MEAS1003:CURR? // measure output current
```

EXAMPLE: Program DC power supply PS 33V Module Channel 3 Over Voltage, Over Current and Under Voltage Protection.

// Use SYST:ERR? after each command to verify no programming errors.

```
*CLS // clear error queue.
*RST // reset module.
OUTP3:STAT 1 // close output relay, and turn supply on.
SOUR3:CURR:PROT 6 // set OCP to 6A
SOUR3:CURR 5 // set Current to 5A
SOUR3:VOLT:PROT 21 // set OVP to 21
SOUR3:VOLT 20 // set Voltage to 20V
SOUR3:UNDERVOLT:PROT 18 // set UVP to 18
MEAS3:VOLT? // measure output voltage
MEAS3:CURR? // measure output current
```

This page intentionally left blank.

SECTION 4

AC MODULE REMOTE PROGRAMMING

4.1 INTRODUCTION

The ReFlex Power™ AC power supply (ACPS) utilizes an Ethernet interface for remote control of all programming, readback, and configuration setup. The syntax of all SCPI commands implemented by the ReFlex Power™ system and documented in this manual, are either SCPI confirmed in the SCPI 1999.0 Specification, Volume 2: Command Reference, or they are customized commands not part of the SCPI definition but conform to SCPI syntax.

4.2 FEATURES AND FUNCTIONS

This section lists the features, programmable functions and readback functions of the ReFlex Power™ ACPS.

FEATURES

- 16-bit programming and 16-bit readback of voltage, and current, and frequency (and phase, if in a phase group)
- Programmable Over/Under Voltage protection with reset
- SCPI compliant command set
- User selectable Constant-Voltage/Constant-Current mode, with reset
- Field-upgradeable firmware via Ethernet
- Soft calibration

PROGRAMMABLE FUNCTIONS

- Output voltage, current, and frequency (and phase if in a phase group)
- Soft limits for voltage and current
- Over Voltage and Under Voltage protection
- Programmable Over Current trip point, response time and delay time
- Programmable Inrush Over Current trip point
- Output enable/disable
- Maskable fault interrupt
- Full calibration

- Programmable voltage range
- Programmable configuration: stand alone, parallel or phase group

READBACK FUNCTIONS

- Measure voltage, current, frequency, and phase
- Voltage, current and frequency settings (phase, if in a phase group)
- Soft voltage and current limits
- Over/Under Voltage and Over Current protection setting
- Status and Accumulated Status registers
- Programming error codes
- Fault codes
- Manufacturer, power supply model, serial number, and firmware version identification

4.3 POWER-ON CONDITIONS

Table 4-1 presents remote power-on conditions for the AC Power Supply.

Table 4-1. Remote Power-On Conditions

Condition	Default
Voltage	0 Volts (initial power-on voltage). Also see CAL<n>:INIT:VOLT
Current	7.140 Amps (initial power-on current). Also see CAL<n>:INIT:CURR
Frequency	60 Hz
OVP Trip Voltage	154 V (110% of Module Maximum Voltage, which is 140 V) +7% (initial power-on OVP). See CAL<n>:INIT:VOLT:PROT
Output	OFF
Parallel	No Modules Paralleled
Voltage Range	Low
Phase	0.0 degrees, stand alone mode
OCP Trip Current	7.42 A (Maximum current 102% of the full scale current, which is 7 A for low voltage range)

4.4 ERROR CODES

The error codes exist in the range of [-32768, 32767]. SCPI reserves the negative error codes and zero, while the error codes greater than zero and in the range of -399 to -300 are defined as device-specific. The negative error codes in the range of -499 to -100 are standardized errors that are reported in the Standard Event Status Register and the Error/Event Queue. Issue the `SYSTem:ERRor?` query to read the error codes, which are stored in the Error/Event Queue.

4.4.1 SCPI ERROR CODES

The following error codes are defined by the SCPI Standard 1999.0, and are supported by the ReFlex Power™ ACPS:

0, No error

The error queue is empty.

-102, Syntax error

An unrecognized command or data type was encountered.

-200, Execution error

This is a generic error when a specific error could not be identified. An execution error could be the result of the following condition:

A command could not be executed due to the current operational condition.

-222, Range Error

A <program data> element being out-of-range; for example, programming 150V, when the maximum allowed value is 135V.

-350, Queue overflow

The Error/Event Queue can contain up to 10 entries. If more than 10 error/event conditions are logged before the `SYSTem:ERRor?` query, an overflow will occur; the last queue entry will be overwritten with error -350. When the queue overflows, the least recent error/event remains in the queue and the most recent error/event is discarded.

NOTE: Some SCPI commands will generate replies as follows, which can be viewed with the `SYST:ERR?` command:

REPLY	DESCRIPTION
Unable to change the Voltage Range - Hardware Prohibited, or	User tries to change the voltage range with <code>SOUR<n>:VOLT:RANGE <bool></code>
Unable to change the Voltage Range Output Enabled or Aux Relay Closed	
Unable to open Module Data file - file system problem, or	User tries to store the module data information and calibration files with <code>CAL<n>:STORE</code>
5 POINT CAL FILE WRITING ERROR, or	
CAL FILE WRITING ERROR	

4.4.2 ERROR/EVENT QUEUE

The Error/Event Queue is a FIFO (First-In-First-Out) buffer for storing detected errors. When the queue is read with the `SYSTEM:ERROR?` query, the error that was detected first will be read first, and the error that was detected last will be read last. When all errors are read, the message 0, "No error" will be returned. Up to 10 errors can be stored before overflow would occur. Overflow will result in error code -350, "Queue overflow" overwriting the last entry. All subsequent errors will be ignored until the queue is read, and space is again available.

4.5 COMMON SCPI COMMANDS

The following commands are common to all SCPI instruments, and are mandatory for conformance to IEEE-488.2. In the following table, the ReFlex Power™ ACPS will be defined as the “device” on the bus.

Command	Description
*CLS	Clear Status Command: Clears all status reporting data structures, including the Standard Event Status Register, Protection Event Status Register, and Error/Event Queue. Also, the Status Byte Register becomes cleared as a result of the reporting registers being cleared. Enable-mask registers are not cleared.
*IDN<n>?	Returns the device identification as an ASCII string. Response: <Manufacturer>,<model>,<serial number>,<firmware version> Example: ELGAR,RFP-A301K-875-1G00,1234A56789,3.100.001
*OPC<n>?	Operation Complete Query: Causes an ASCII “1” to be placed in the output queue when all previous operations are complete. This Command only functions properly in FW Ver. 3.000.000 or newer. In previous FW Versions, hard coded time delays in host programming were mandatory. When AC Modules are in a group, and the slaves are directly commanded, *OPC<n>? will return a “0” indicating that the previous command has been executed but not applied. The Group Master then needs to be commanded, which will cause a group synchronous trigger to be issued, causing the slave module to apply the new setting.
*RST<n>	<n> is the module number. Reset Command: Resets the device (module <n>) to the following state: Output voltage set to zero. Output isolation and remote sense relays are opened. Settings of output voltage, current, frequency, phase, Over Current shutdown time delay and Output configuration are reset to Power On default values. Clears all status reporting data structures, including the Protection Event Status Register and Standard Event Status Register; Status Byte Register is cleared when reporting registers are cleared. Enable registers and Error/Event Queue are not cleared.
*TST<n>	Initiate self test
*TST<n>?	Returns the results from the last self test the module performed. Returns a decimal value, convert to Hex because more than one bit can be set. See Table 2-6

4.6 CALIBRATION SCPI COMMANDS

CAUTION



Before attempting to execute any of the ACPS calibration commands, follow the calibration procedures in the ReFlex Power™ Operation Manual (M380056-01), AC Section. If calibration is not performed properly, functional problems could arise, preventing the ReFlex Power™ ACPS from operating properly. Qualified personnel who are appropriately trained to deal with attendant hazards must perform calibration.

4.6.1 CALIBRATION SCPI COMMAND SUMMARY

```

CALibration<n>
  :MEASure
    :IADC
  :OFFSET
    :CALCulate
  :OFFSET?
    :VADC
      :OFFSET
        :CALC
      :OFFSET?
    :VLOCAL
      :OFFSET?
    :ILOCAL
      :OFFSET?
    :VREMOTE
      :OFFSET?
    :OFFSET
      :CALC
  :CALPOTS
    :GAIN [NRi]
      :START
      :CURR <NRf>
      :CALC
    :GAIN?
    :CALMON <NRi>
    :CALMON?
    :OFFSET
      :CALC
    :OFFSET?
    :A2D?
  :UNLock "PASSWORD"
  :STORE
  :LOCK
  :OUTPut

```

```

:DCLOOP <bool>
:DAC
    :OFFSET
        :CALC
    :OFFSET?
    :COUNTS
    :POINT1 <NRf>
    :POINT2 <NRf>
:LDF
    :GAIN?
    :CALC
:VOLTage
    :COUNTS <NRi>
    :PROTection
        :COUNTS <NRi>
    :FIVEPOINT <1-5> <NRf>
    :FIVEPOINT?
    :CALC
:CURRENT
    :COUNTS <NRi>
    :PROTection
        :COUNTS <NRi>
    :FIVEPOINT <1-5> <NRf>
    :FIVEPOINT?
    :CALC
:FREQ
    :CURR
        :DEFAULT
    :CURR <1-7> <NRf>
    :CALC
    :POWer
        :CALibrate <NRi>
        :CALC
        :CALC?
:INITial
    :CURRent <0+NRf>
        :PROTection <NRf>
        :PROTection?
    :CURRent?
    :VOLTage <0+NRf>
        :PROTection <NRf>
        :PROTection?
        :RANGE <bool>
        :RANGE?
    :VOLTage?
    :UNDERVOLTage
        :PROTection <NRf>

```

```

        :PROtection?
:PHASe <NRi>
:PHASe?
:FREQuency <NRi>
    :FREQuency?
    :DEFault

:MODule
    :LASTCAL <Date>
    :LASTCAL?
    :NEXTCAL <Date>
    :NEXTCAL?
    
```

4.6.2 CALIBRATION SCPI COMMAND REFERENCE

Command	Description
CALibration<n>	Calibration subset of SCPI command sets
:MEASure	
:IADC	Current ADC
:OFFSET:CALC	Calibrate the current ADC offset.
:OFFSET?	Query the offset of the current ADC
:VADC	Voltage ADC
:OFFSET:CALC	Calibrate the Voltage ADC offset.
:OFFSET?	Query the offset of the Voltage ADC
:VLOCAL	Local Voltage
:OFFSET?	Query the offset of the local Voltage
:ILOCAL	Local current
:OFFSET?	Query the offset of the local current
:VREMOTE	Remote Voltage
:OFFSET?	Query the offset of the Remote Voltage
:OFFSET:CALC	Calibrate the offset of the VLOCAL,ILOCAL and VREMOTE
:CALPOTS	Analog gain and offset pots
:GAIN <NRi>	This is an 8 bit value (0 to 255)
:START	Start the gain calpot calibration
:CURRENT <NRf>	Enter the floating point AC current value
:CALC	Calibrate the gain calpot
:GAIN?	Query the gain calpot set value.
:CALMON <NRi>	Set the MUX for the current A2D
:CALMON?	Query current A2D MUX
:OFFSET:CALC	Calibrate the offset pot
:OFFSET?	Query the set point of the offset pot
:A2D?	Query current A2D value
:UNLock <string>	Unlock the calibration data file; enables storage of the calibration constants. The enable string is <"6867">.
:STORE	Store the calibration or module data
:LOCK	Lock the files
:OUTPUT	
:DCLOOP <bool>	Set the DCLOOP on or off. ON or 1 = turn on the DCLOOP and OFF or 0 = Turn off the DCLOOP

Command	Description
:DAC	Voltage DAC
:OFFSET:CALC	Calibrate the voltage DAC offset.
:OFFSET?	Query the DAC offset value
:COUNTS <NRi>	Set the DAC count
:POINT1 <NRf>	Measure DC voltage using DMM and enter the first DC voltage reading.
:POINT2 <NRf>	Set the second count value and then enter the second DC voltage reading
:LDF	Line Drop Fault
:GAIN?	Query the gain of the LDF register
:CALC	Calibrate the LDF gain
:VOLTage	
:COUNTS <NRi>	Set the voltage in terms of counts
:PROTECTION	(must be used with the following :COUNTS command)
:COUNTS <NRi>	Set over voltage protection value in term of count
:FIVEPOINT<1-5> <NRi>	Set the five points AC voltage
:FIVEPOINT?	Query the calibrated five points
:CALC	Calculate voltage calibration.
:CURREnt	
:COUNTS <NRi>	Set the current in terms of counts
:PROTECTION	(must be used with the following :COUNTS command)
:COUNTS <NRi>	Set over current protection value in term of count
:FIVEPOINT<1-5> <NRi>	Set the five points AC current
:FIVEPOINT?	Query the calibrated five points
:CALC	Calibrate current.
:FREQ	
:CURR:DEFAULT	Set the frequency calibration to default
:CURR <1-7> <NRf>	Set the actual AC current to frequency calibration. This is 7 point frequency calibration
:CALC	Calculate the frequency calibration data
:INITial	Set initial values
:CURREnt <0+NRf>	Set the initial current value
:PROTection <NRf>	Set the initial current protection limit
:PROTection?	Query the initial current protection value
:CURREnt?	Query the initial current value
:VOLTage <0+NRf>	Set the initial voltage value
:PROTection <NRf>	Set the initial over voltage protection limit
:PROTection?	Query the initial over voltage protection value
:RANGE <bool>	Set the initial voltage range 0 = low range and 1 = high range
:RANGE?	Query the initial voltage range
:VOLTage?	Query the initial voltage set point
:UNDERVOLTage	Set the initial undervoltage protection limit
:PROTection<NRf>	Set the initial under voltage protection limit
:PROTection?	Query the initial under voltage protection limit
:PHASe <NRi>	Set the initial phase of the module. This will be affective only when unit is in phase group
:PHASe?	Query the initial phase set point

Command	Description
:STATe <bool> ¹	Set the initial POR output state of the unit
:STATe?	Query the initial POR output state setting of the unit
:FREQuency <NRi>	Set the initial frequency of the unit
:FREQuency?	Query the initial frequency of the unit
:DEFault	Set the initial value to default
:MODule	
:LASTCAL <Date>	Set the last calibration date
:LASTCAL?	Query the last calibration date
:NEXTCAL <Date>	Set the next calibration date
:NEXTCAL?	Query the next query calibration date.

¹ If CAL:INIT:STATe is '1', the module will automatically turn on as if an OUTP:STATe 1 command had been received. This will only occur during initial power up, *RST will only restore the saved CAL:INIT values. The unit will not automatically turn on if enabled, after a *RST.

4.7 MEASURE SCPI COMMANDS

4.7.1 MEASURE SCPI COMMAND SUMMARY

```

MEASure<n>
  :CURRent?
  :VOLTage?
  :FREQuency?
  :PHASe?
  :POWer
    [ :AC]
      [ :REAL]?
        :APParent?
        :VAR?
        :PFACTOR?
        :CFACTOR?
        :IPEak?

```

4.7.2 MEASURE SCPI COMMAND REFERENCE

Command	Description
MEASure<n>	MEASURE subset of SCPI command sets. Valid measure parameter values: source or phase = 1-3. The default source or phase is 1.
:CURRent?	Returns measured RMS output current.
:VOLTage?	Returns the RMS output voltage.
:FREQuency?	Returns the set measured frequency of the unit in Hz
:PHASe?	Returns the set phase angle of the unit. If the unit is in a standalone mode then phase is 0.0 Degrees.
:POWer?	Returns real power measurement
:APParent?	Returns apparent power measurement (VA)
:VAR?	Returns reactive power measurement
:PFACTOR?	Returns Power Factor measurement
:CFACTOR?	Returns current crest factor
:IPEak?	Returns peak current reading

4.8 OUTPUT SCPI COMMANDS

4.8.1 OUTPUT SCPI COMMAND SUMMARY

```

OUTPut<n>
  :STATe <bool>
  :STATe?
  :AUXRelay <bool>
  :AUXRelay?
  :ISOLation ?
  :SENSe?
    
```

4.8.2 OUTPUT SCPI COMMAND REFERENCE

Command	Description
OUTPut<n>	OUTPUT subset of SCPI commands.
:STATe <bool>	Sets the output On or Off. Arguments are 1/ON, or 0/OFF.
:STATe?	Returns the state of the supply, 1 = On, and 0 = Off.
:AUXRelay <bool>	Set the Auxiliary Relay to open or close. 1= close ,and 0 = open. Note: AUX Relay can be manipulated only when the output is On, and output signal frequency is set within 350 - 1000 Hz range.
:AUXRelay?	Query the state of the Auxiliary relay
:ISOLation?	Query the state of the Isolation relay.
:SENSe?	Query the state of the Sense relay.

4.9 SOURCE SCPI COMMANDS

4.9.1 SOURCE SCPI COMMAND SUMMARY

```

SOURCE<n>
  :CURRENT1 <NRf>
  :CURRENT?
    :MODE ?
    :PROTECTION1 <NRf>
    :PROTECTION?
      :TIMER <NRf>
      :TIMER?
      :TCONSTANT <NRf>
      :TCONSTANT?
  :INRUSHcurr
    :PROTECTION1 <NRf>
    :PROTECTION?
  :FREQUENCY <NRf>
  :FREQUENCY?
  :PHASE <NRf>
  :PHASE?
    :LEAD
    :LAG
  :MODE <bool>
  :MODE ?
  :VOLTAGE1 <NRf>
  :VOLTAGE?
    :RANGE <bool>
    :RANGE?
    :PROTECTION <NRf>
    :PROTECTION?
    :UPSET4 <NRf> , <NRf> , <NRf> , <NRf>
    :UPSET?
  :UNDERVOLTAGE
    :PROTECTION <NRf>
    :PROTECTION?
      :TRIPPED?
      :STATE <bool>
      :STATE?
      :MODE
        :SHUTDOWN <bool>
        :SHUTDOWN?

```

4.9.2 SOURCE SCPI COMMAND REFERENCE

Command	Description
SOURCE<n>	SOURCE subset of SCPI command sets.
:CURRENT ¹ [<NRf>]	Sets the output current setpoint in a range 0 – 102% of maximum current for specific voltage range. Default current set point is 102% of maximum current for specific voltage range. The *RST command resets the Current to the default setpoint.
:CURRENT?	Returns the present output current setpoint.
:MODE ?	Query CC/CV mode: 1 = CC, 0 = CV
:PROTECTION ¹ [<NRf>]	Sets the output current protection setpoint. Default current protection setpoint is 106% of the maximum current for the specific voltage range. The reset command sets the default current protection set point.
:PROTECTION?	Returns the present output current protection set point.
:TIMER <NRi>	Set Over Current Protection Hold-Off Timer. By default this value is set to 500 mS. Valid range is 1–500 mS.
:TIMER?	Query the value of Over Current Protection Hold-Off Timer
:TCONSTANT <NRi>	Sets Over Current / Inrush Over Current Protection IRR Time Constant (OCP/IOCP IRR Time Constant). The default value is 100 mS, valid range is 20–250 mS
:TCONSTANT?	Query OCP/IOCP IRR Time Constant value
:INRUSHCURR	
:PROTECTION ¹ <NRf>	Sets Inrush Over Current Protection (0-144% of full current)
:PROTECTION ?	Query Inrush Over Current Protection
:FREQUENCY <NRf>	Sets the output frequency set point of the present source.
:FREQUENCY?	Returns the output frequency setpoint.
:PHASE ¹ <NRf>	Sets the phase angle offset for the module, with respect to the Phase Reference. Counterclockwise phase or rotation is the default; therefore the phase angle offset is lagging the reference. The Phase Group Master must be set last.
:PHASE?	Returns the present phase angle offset.
:LEAD ²	Set the specified module to be leading the reference.
:LAG ²	Set the specified module to be lagging the reference.
:MODE <bool>	Set <1>; Constant Current (CC) and Constant Voltage (CV) operation with automatic transitions (Auto) as determined by the load. The output will be regulated to their respective setpoints. Set <0>; Constant Voltage mode operation only, with CC mode disabled. Only the output voltage will be regulated to its setpoint. The Current setpoint is ignored. In both modes, all Voltage and Current related protection supervisories, (OVP, OCP, ...) are functional.
:MODE ?	Query Operation mode, 1 = Auto, 0 = CV only mode
:VOLTAGE ^{1, 3} <NRf>	Sets the output voltage setpoint (0 – 102%).
:VOLTAGE?	Returns the present output voltage set point.
:RANGE <bool>	Sets the voltage range of the unit to either High (1) or Low (0) voltage range. Default voltage range of the unit is Low. Command executes when the unit state is Off. Reset command sets the voltage range to default.
:RANGE?	Query the voltage range of the unit.

Command	Description
:PROTection<NRf>	Sets the Over -Voltage Protection setpoint.
:PROTection?	Returns the Over Voltage Protection setpoint.
:UPSET ⁴ <NRf> , <NRf> , <NRf> , <NRf>	The UPSET Event has four arguments that allow surge/sag or dropouts to be programmed to start at a specific phase delay, to a specified RMS voltage level, for specified time, and then apply an after event voltage level.
:UPSET? ⁴	Returns the above UPSET Event parameters if the event has not finished. The returned duration value will be zero when the event is complete.
:UNDERVOLTage	
:PROTection[<NRf>]	Sets the Under Voltage Protection setpoint.
:PROTection?	Returns the Under Voltage Protection setpoint.
:TRIPped?	Query whether Under Voltage Protection supervisory tripped or not
:STATe <bool>	Sets or clears the global detect enable for the Under Voltage Protection supervisory. 0 = disable, 1 = enable
:STATe?	Query the global detect enable for the Under Voltage Protection supervisory. 0 = disabled, 1 = enabled
:MODE	
:SHUTdown<bool>	Set or clear the shutdown enable for Under Voltage Protection supervisory
:SHUTdown?	Query the shutdown enable for Under Voltage Protection supervisory

¹See Section 4.12 for examples for using Group operation.

² **PHASE:LEAD** specifies that the specified PHASE <NRf> angle value is the number of degrees that the rising waveform zero cross will occur **before** the Phase Reference in time. Cleared by *RST, by command, or Power cycle. Power on default is LAG.

² **PHASE:LAG** specifies that the specified PHASE <NRf> angle value is the number of degrees that the rising waveform zero cross will occur **after** the Phase Reference in time. Cleared by *RST, by command, or Power cycle. Power on default is LAG.

The Phase Reference is a timing signal that is generated by the Phase Master Module. It is used by the Phase Master and Slave Modules to offset their own rising zero cross waveform timing from the Phase Reference time marker. The PHASE setpoint accepts values between -360.0 and +360.0 degrees, this will interact with LEAD/LAG.

³ *Prior* to setting the Voltage above 125V in the low range or above 250V in the high range, you must set the three Current related setpoints, SOURce<n>:CURRent, SOURce<n>:CURRent:PROTection and SOURce<n>:INRUSHCURRent:PROTection, else a “parameter out of range” error will occur. The reason is that these three Current setpoints are designed to limit the maximum continuous power to 875VA, and the protection values to safe levels; therefore, they must be lowered in order to raise the voltage above the values stated for the low range or for the high range. The three Current setpoint formulae are as follows:

Current Setpoint (I_{set}) as a function of voltage:

Low Range formula: $I_{set}(V) = I_{set}(max) * 125 / V_{set}$, for $V_{set} > 125$

Example: to set the voltage to 137V. $I_{set}(137) = 7.14 * 125 / 137 = 6.514A(max)$

SOUR<n>:CURR 6.51

High Range formula: $I_{set}(v) = I_{set}(max) * 250 / V_{set}$, for $V_{set} > 250$ ($I_{set}(max) = 3.57A$)

Over-Current Protection Setpoint (OCP) as a function of voltage:

Low Range formula: $I_{ocp} = I_{ocp}(max) * 125 / V_{set}$. $I_{ocp}(max) = 7.42A$

Example: $I_{ocp} = 7.42 * 125 / 137 = 6.77A$

`SOUR<n>:CURR:PROT 6.77`

High Range formula: $I_{ocp}(v) = I_{ocp}(max) * 250 / V_{set}$, for $V_{set} > 250$ ($I_{ocp}(max) = 3.71A$)

Inrush Over-Current Protection Setpoint (IOCP) as a function of voltage:

Low Range formula: $I_{iocp} = I_{iocp}(max) * 125 / V_{set}$. $I_{iocp}(max) = 10.1A$

Example: $I_{iocp} = 10.1 * 125 / 137 = 9.21A$

`SOUR<n>:INRUSHCURR:PROT 9.21`

High Range formula: $I_{iocp}(v) = I_{iocp}(max) * 250 / V_{set}$, for $V_{set} > 250$ ($I_{iocp}(max) = 5.05A$)

The **last** step is to set the desired voltage (V_{set}):

`SOUR<n>:VOLT 137`

⁴ The Upset Event feature in the AC Module is implemented by switching to a different in-phase AC RMS voltage value during the time specified by the duration parameter. The upset event is generated by “pasting” a segment of the in-phase Volt1 waveform, starting at the parameter **Phase** position, for parameter **Duration** length, in place of the presently output waveform.

The Master/standalone module will at the start of the event, issue a 1 ms TTL positive trigger signal on Pin 2, referenced to return on Pin 7, of the DB-9 Interface connector. The rising edge of the trigger signal is output when the **Phase** parameter delay expires. The trigger signal has no programmable options. The execution of the command for a stand-alone or Group Master is immediate.

The **Phase Reference** time marker is a timing signal that is generated by a Master or stand-alone AC module. It is used by a module to mark when to apply their own phase offsets to set the timing of their individual rising zero cross of the output voltage waveform. Zero cross and UPSET event timing are referenced to the same time marker, but are independent of each other.

The **SOUR<n>:VOLT:UPSET Phase,Volt1,Duration,Volt2** command allows the Module to output a transient voltage upset event; such as surges, sags, dropouts, brownouts, and spikes.

Phase: The Phase specifies the delay from the Phase Reference time marker to start the upset event. A value of 0.0 to 3600.0 degrees is accepted, this allows the upset event to be skewed across multiple cycles in a Phase group, if needed.

Volt1: The RMS voltage that will be output during the upset event.

Duration: The length of time the output will be disturbed in seconds, from 100 μ s to 85.899 seconds. Voltage excursions of duration shorter than 1 ms may be limited by module power bandwidth and output loading.

Volt2: The RMS voltage to which the supply will return to, when the disturbance is complete.

The Volt1 or Volt2 values must conform to the limits set in Note 3 above.

The **:UPSET?** command will return the programmed values. If the command has completed execution, the returned Duration value will be zero.

Example: Three phase group; 120 volts, 60 Hz; Phase A = 0 degrees (Master module slot 3); Phase B = 120 degrees (1st slave slot 6); Phase C = 240 degrees (2nd slave slot 9). To have all of the modules drop out at the same moment in time for ¼ cycle starting at Phase A at 90 degrees (Phase B at 330 deg., Phase C at 210 deg.) from the **Phase Reference** time marker, the following command sequence would be used:

```
SOUR9:VOLT:UPSET 90.0,0.0, 4.1666667e-3,120.0
SOUR6:VOLT:UPSET 90.0,0.0, 4.1666667e-3,120.0
*OPC9? // These *OPC?'s will return 0, which means that the commands were
*OPC6? // processed, but are waiting to be triggered by the Master module.
SOUR3:VOLT:UPSET 90,0, 4. 1666667e -3,120 // Execute on Master and trigger the slaves.
*OPC3? // Will return 0 if not complete, Will return a 1 if execution is complete.
```

4.10 STATUS SCPI COMMANDS

4.10.1 STATUS SCPI COMMAND SUMMARY

```

STATUS<n>
  :MODule
    :ENABles <0+NR1>
    :ENABles1 <0+NR1>
    :ENABles?
    :ENABles1?
    :FAULts?
    :FAULT1?
    :HWREV?
    
```

4.10.2 STATUS SCPI COMMAND REFERENCE

Command	Description
STATUS<n>:MODule	
:ENABles <0+NR1>	Enable the supervisories register 0. Use Table 4-6 for bit definitions.
:ENABles1 <0+NR1>	Enable the supervisories register 1. Use Table 4-7 for bit definitions.
:ENABles?	Query the supervisories register 0
:ENABles1?	Query the supervisories register 1
:FAULts?	Query the module faults register 0. See Table 4-6 to decode.
:FAULT1?	Query the module faults register 1. See Table 4-7 to decode.
:HWREV?	Returns Hardware Rev Value.

Table 4-2. AC Enable Register 0

Bit	Hex Value	Mnemonics	Description
31-27			RESERVED
26	0x04000000	IOTP4	Impending Over Temperature – 4 Fault
25	0x02000000	IOPT3	Impending Over Temperature –3 Fault
24	0x01000000	OTP4	Over Temperature –4 Fault
23	0x00800000	OTP3	Over Temperature –3 Fault
22	0x00400000	BCKRI	Back Plane remote inhibit
21	0x00200000	IOCP	Inrush Over Current
20	0x00100000	DCUVP	DC Bus Under Voltage Protection
19	0x00080000	DCOVP	DC Bus Over Voltage Protection
18	0x00040000	SYNCF	Synchronization Fault
17	0x00020000	DCP	DC protection Fault
16	0x00010000	IIPK	Inverter Peak Over Current
15	0x00008000	UVP12	Under Voltage Plus 12 Volt Fault
14	0x00004000	OVP5	Over Voltage Plus 5 Volt Fault
13	0x00002000	UVP5	Under Voltage Plus 5 Volt Fault
12	0x00001000	AFF	Air Flow Fault
11	0x00000800	OTP2	Over Temperature –2 Fault
10	0x00000400	OTP1	Over Temperature –1 Fault
9	0x00000200	IOTP2	Impending Over Temperature –2 Fault
8	0x00000100	IOTP1	Impending Over Temperature –1 Fault
7	0x00000080	DES_MODE	Desired Mode – CC/CV switch mode Fault
6	0x00000040	UVP	Under Voltage Fault
5	0x00000020	ROVP	Redundant Over Voltage Fault
4	0x00000010	ROCP	Redundant Over Current Fault
3	0x00000008	OVP	Over Voltage Fault
2	0x00000004	OCP	Over Current Fault
1	0x00000002	ADC	ADC Timing Fault
0	0x00000001	LDF	Line Drop fault

Table 4-3. AC Enable Register 1

Bit	Hex Value	Mnemonics	Description
16-31			RESERVED
15	0x00008000	AUXF	Auxiliary Relay Fault
14	0x00004000	ANALOG	Analog Fault
13	0x00002000		RESERVED
12	0x00001000		RESERVED
11	0x00000800	MDENA	Front Panel Module Enable False
10	0x00000400	GPRF	Group Fault
9	0x00000200	PRST	Power Reset
8	0x00000100	PRIENA	Under/Over Voltage on PFC Bus
7-4			RESERVED
3	0x00000008	GNDF	Ground Fault
2	0x00000004	OVM12	Over Voltage Minus 12 Volts Fault
1	0x00000002	UVM12	Under Voltage Minus 12 Volts Fault
0	0x00000001	OVP12	Over Voltage Plus 12 Volts Fault

4.11 SYSTEM SCPI COMMANDS

4.11.1 SYSTEM SCPI COMMAND SUMMARY

SYSTem
:ERRor?

4.11.2 SYSTEM SCPI COMMAND REFERENCE

Command	Description
SYSTem	SYSTEM subset of SCPI command sets
:ERRor?	Returns the last error logged in the Error/Event Queue. If there are no errors, 0, No error is returned.

4.12 EXAMPLE SCPI COMMANDS TO SET PHASE AND PARALLEL GROUPS

4.12.1 EXAMPLES CREATING A PHASE GROUP

EXAMPLE 1: Set the group using 3 AC module (units at slot 4, 8,12)

Slot 4, Module will become master of the phase group and the slot 8 and 12 units will be the slaves of the phase group. Default phase angle for the slot 4 = 0 degrees, slot 8 = 120 degrees and slot 12 = 240 degrees.

```

SYSTem:GROup:DEFine:PHASe 4,8,12 // Command to form the phase group.
SYSTem:GROup:CAT:PHASe? // Query the group
OUTP1004:STATE 1 // Turn on all the units as a group
*OPC1004? // Send next command after a '1' is returned
SOUR1004:VOLT 125 // Set the group to 125 volts
*OPC1004? // Send next command after a '1' is returned
SOUR1004:CURR 3 // Set all the modules to 3 Amps
*OPC1004? // Send next command after a '1' is returned
SOUR12:PHASE 200 // Set the slot 12 AC module to 200 degree phase
*OPC12? // Send next command after a '0' is returned
SOUR8:PHASE 100 // Set the slot 8 AC module to 100 degree phase
*OPC8? // Send next command after a '0' is returned
SOUR4:PHASE 0 // Set the phase of slot 4 unit to 0 degree and execute
synchronous phase change on all three units.
*OPC4? // Send next command after a '1' is returned
Set a different voltage for each member of the phase group:
SOUR12:VOLT 110 // Set AC module in slot 12 to 110 volts
*OPC12? // Send next command after a '0' is returned
SOUR8:VOLT 90 // Set AC module in slot 8 to 90 volts
    
```

```

*OPC8? // Send next command after a '0' is returned
SOUR4:VOLT 75 // Set AC module in slot 4 to 75 volts and execute
               // synchronous voltage change on all three units
*OPC4? // Send next command after a '1' is returned
SYST:GROUP:DELETE 1004 // Delete 1004 group
or
SYST:GROUP:DELETE:ALL // Delete all groups

```

4.12.2 EXAMPLE CREATING A PARALLEL GROUP

Create a Parallel group using three AC modules (units at slot 4, 8,12)

```

SYSTem:GROup:DEFine:PARAllel 4,8,12 // Create the parallel group
SYSTem:GROup:CAT:PAR? // Query the group
OUTP1004:STATE 1 // Turn on all the units of the group
*OPC1004? // Send next command after a '1' is returned
SOUR1004:VOLT 120 // Set the group to 120 volts
*OPC1004? // Send next command after a '1' is returned
SOUR1004:CURR 21 // Each module may draw a maximum of 7 Amps. In
                  // parallel group, the maximum current for the group is
                  // the number of group members * the maximum
                  // current of 7 Amps. (Refer to specifications for high
                  // range and low range
*OPC1004? // Send next command after a '1' is returned
SYST:GROUP:DELETE 1004 // Delete 1004 group
or
SYST:GROUP:DELETE:ALL // Delete all groups

```

This page intentionally left blank.

SECTION 5

LOAD MODULE REMOTE PROGRAMMING

5.1 INTRODUCTION

This section covers the remote programming option for the ReFlex Power™ Active Load Module. This interface enables operation of the Load from a computer via the Ethernet, allowing full remote programming control and monitoring of the Load module.

The syntax of all SCPI commands implemented by the ReFlex Power™ system and documented in this manual, are either SCPI confirmed in the SCPI 1999.0 Specification, Volume 2: Command Reference, or they are customized commands not part of the SCPI definition but conform to SCPI syntax.

5.2 FEATURES AND FUNCTIONS

FEATURES

- 16-bit programming and 16-bit readback of voltage and current and resistance
- Programmable over voltage, over current and over power protection
- SCPI compliant command set
- User selectable Constant Resistance or Constant Current mode
- Field-upgradeable firmware via Ethernet
- Soft calibration

PROGRAMMABLE FUNCTIONS

- Input current and resistance
- Soft limits for voltage, power and current
- Over voltage protection
- Input enable/disable
- Maskable fault interrupt
- Full calibration

READBACK FUNCTIONS

- Actual measured voltage, power and current
- Voltage, current and resistance settings
- Soft voltage, power and current limits
- Status and Accumulated Status registers
- Programming error codes
- Fault codes
- Manufacturer, power supply model, serial number, and firmware version identification

5.3 POWER-ON CONDITIONS

Table 5-1 presents the power-on conditions for the Active Loads.

Table 5-1. Load Power-on Conditions

Condition	Default
Current	0 Amps (initial power-on current). Also see CAL<n> : INIT : CURR
Soft Voltage Limit	Model maximum voltage
Soft Current Limit	Model maximum current
OVP Trip Voltage	Model maximum voltage +7% (initial power-on OVP). See CAL<n> : INIT : VOLT : PROT
Input	OFF, relays open
Grouped	No Modules Grouped (example paralleled)
Soft Power Limit	Model power limit

5.4 ERROR CODES

The error codes exist in the range of [-32768, 32767]. SCPI reserves the negative error codes and zero, while the error codes greater than zero and in the range of -399 to -300 are defined as device-specific. The negative error codes in the range of -499 to -100 are standardized errors that are reported in the Standard Event Status Register and the Error/Event Queue. The error codes that are stored in the Error/Event Queue are read with the `SYSTem:ERRor?` query.

5.4.1 SCPI ERROR CODES

The following error codes are defined by the SCPI Standard 1999.0, and are supported by the ReFlex Power™ Active Load (AL).

0, No error

The error queue is empty.

-102, Syntax error

Message returned: `SYNTAX_ERROR: -102`. An unrecognized command or data type was encountered.

-200, Execution error

Message returned: `EXEC_ERROR: -200`. Command could not be executed.

-222, Data out of range

Message returned: `DATA_OUT_OF_RANGE: -222`. An out-of-range command parameter had been entered.

-350, Queue overflow

The Error/Event Queue could contain up to 10 entries. If more than 10 error/event conditions are logged before the `SYSTem:ERRor?` query, an overflow will occur; the last queue entry will be overwritten with error -350. When the queue overflows, the least recent error/event remains in the queue and the most recent error/event is discarded.

5.4.2 ERROR/EVENT QUEUE

The Error/Event Queue is a FIFO (First-In-First-Out) buffer for storing detected errors. When the queue is read with the `SYSTem:ERRor?` query, the error that was detected first will be read first, and the error that was detected last will be read last. When all errors are read, the message **0, No error** will be returned. Up to 10 errors could be stored before overflow would occur. Overflow will result in error code -350, “Queue overflow” overwriting the last entry. All subsequent errors will be ignored until the queue is read, and space is again available.

5.5 COMMON SCPI COMMANDS

The following commands are common to all SCPI instruments, and are mandatory for conformance to IEEE 488.2. In the following table, the ReFlex Power™ AL will be defined as the “device” on the bus.

Command	Description
*CLS	Clear Status Command: Clears all status reporting data structures, including the Standard Event Status Register, Protection Event Status Register, and Error/Event Queue. Also, the Status Byte Register is cleared as a result of the reporting registers being cleared. Enable registers are not cleared.
*IDN<n>?	Identification Query: Returns the device identity as an ASCII string: <manufacturer>,<model>,<serial number>,< firmware version>. Example: ELGAR,RFP-L3500-750-1G00,0721A00746,3.000.001
*OPC<n>?	Operation Complete Query: Returns the integer value 1, when all pending operations are complete.
*RST<n>	Reset Command: Resets the device to the following state: 1. Input current set to zero in Constant Current mode. 2. Input power stage amplifiers disabled. 3. Clears all status reporting data structures, including the Status Byte Register, Standard Event Status Register, and Error/Event Queue. Enable registers are not cleared.
*TST<n>	Initiate self test
*TST<n>?	Returns the results from the last self test the module performed. Returns a decimal value, convert to Hex because more than one bit can be set. See Table 2-6

5.6 CALIBRATION SCPI COMMANDS



CAUTION

Before attempting to execute any of the Load calibration commands, follow the calibration procedures in the ReFlex Power™ Operation Manual (M380056-01), Active Loads Section. If calibration is not performed properly, functional problems could arise, preventing the ReFlex Power™ Load(s) from operating properly. Qualified personnel who are appropriately trained to deal with attendant hazards must perform calibration.

5.6.1 CALIBRATION SCPI COMMAND SUMMARY

```

CALibrate<n>
  :CALPOTS
    :GAIN
      :START
      :CURRENT <NRf>
    :CALCulate
    :GAIN?
    :OFFSet?
  :INITial
    :CURRENT <NRf>
    :CURRENT?
    :CURRENT
      :PROTection <NRf>
      :PROTection?
    :POWer
      :PROTection <NRf>
      :PROTection?
    :RESistance <NRf>
    :RESistance?
    :STATE <bool>
    :STATE?
    :UNDERVOLTage
      :PROTection <NRf>
      :PROTection?
    :VOLTage
      :PROTection <NRf>
      :PROTection?
  :INPut
    :CURRENT
      :COUNTS <NRi>
      :CALCulate
      :FIVEPOINT <1-5> <NRf>
      :RANGE <bool>
    :CURRENT <1-2> <NRf>
    :CONDuctance
      :COUNTS <NRi>

```

```

        :CALCulate
        :VOLTage <1-2> <Nrf>
:MEASure
        :OFFSET
        :CALCulate
:UNLock <string>
:STORE
:LOCK
    
```

5.6.2 CALIBRATION SCPI COMMAND REFERENCE

Command	Description
CALibrate<n>	CALIBRATION subsystem
:CALPOTS	Calpots
:GAIN	Gain Pot
:START	Start the gain pot calibration
:CURRENT <Nrf>	Enter the current value
:CALCulate	Calibrate the gain calpot
:GAIN?	Returns the gain pot
:OFFSet?	Returns the offset
:INITial	Calibration Initialization subsystem
:CURRENT?	Get the initial current value
:CURRENT <Nrf>	Set the initial current value
:CURRENT	
:PROTection <Nrf>	Set the initial over current protection value
:PROTection?	Return the initial over current protection value
:POWer	
:PROTection <Nrf>	Set the initial maximum power protection value
:PROTection?	Return the initial maximum power protection value
:RESistance <Nrf>	Set the initial resistance value 1.0-5.0KΩ
:RESistance?	Return the initial resistance value
:STATE <bool> ¹	Set the initial Cold Power up state to On/Off
:STATE?	Return the initial Cold Power up state setting
:UNDERVOLTage	

Command	Description
:PROTection <NRf>	Set the initial undervoltage protection value
:PROTection?	Return the initial undervoltage protection value
:VOLTag	
:PROTection?	Get the initial over voltage protection value
:PROTection <NRf>	Set the initial over voltage protection value
:INPut	Calibrate Input subsystem
:CURRent	Calibrate Input Current subsystem
:COUNTS <NRi>	Enter the input current counts
:CALCulate	Calculate the current calibration
:FIVEPOINT <1-5> <NRf>	Set the input current value for each calibration point
:RANGE <bool>	Change the current range
:CURRent <1-2> <NRf>	Set the input current calibration points
:CONDuctance	Calibrate Conductance subsystem
:COUNTS <NRi>	Set the conductance counts
:CALCulate	Calculate the conductance calibration
:VOLTag <1-2> <NRf>	Set the input voltage calibration points
:MEASure	Calibrate Measure subsystem
:OFFSET	Calibrate Measure Offset subsystem
:CALCulate	Calculate the voltage calibration
:UNLock <string>	Unlock the calibration data file; enables storage of the calibration constants. The enable string is <"6867">.
:STORE	Stores the calibration constants.
:LOCK	Locks the calibration data file; disables calibration data store, thereby preventing storage of the calibration constants.

5.7 MEASURE SCPI COMMANDS

5.7.1 MEASURE SCPI COMMANDS SUMMARY

```
MEASure<n>
  :CURRent?
  :VOLTag?
  :POWER?
```

5.7.2 MEASURE COMMANDS REFERENCE

Command	DESCRIPTION
MEASure<n>	MEASURE subsystem of commands
:CURRent?	Returns the floating-point value of the DC input current.
:VOLTag?	Returns the floating-point value of the DC input voltage.
:POWER?	Returns floating point value of DC power

5.8 INPUT SCPI COMMANDS

5.8.1 INPUT SCPI COMMAND SUMMARY

```

INPut<n>
  :STATe <bool>
  :STATe?
  :ISOLation <bool>
  :ISOLation?
  :SENSe <bool>
  :SENSe?
  :CURRent
    :EXTeRnal <NRi>
      :LIMit <NRf>
      :LIMit?
    :EXTeRnal?
  :MODE?

```

5.8.2 INPUT SCPI COMMAND REFERENCE

Command	Description
INPut<n>	INPUT subsystem of commands
:STATe <bool>	Turns the input power stages ON or OFF. Valid arguments are 1/ON (input on) or 0/OFF (input off, high impedance).
:STATe?	Returns the state of the input power stages, 1 = on, or 0 = off.
:ISOLation <bool>	Opens/Closes the ISOLation relay, SENSe relay must be open.
:ISOLation?	Returns the state of the ISOL relay
:SENSe <bool>	Opens/Closes the SENSe relay, ISOL must be closed to change SENSe
:SENSe?	Returns the state of the SENSe relay
:CURRent	
:EXTeRnal <NRi>	This command is used to select IAI mode of the module. When input value = 1: means select IAI mode and 0: means select SCPI mode. When the module is in the IAI mode current set point given by SCPI is ignored. But as soon as the SCPI mode is selected current set point gets executed.
:LIMit <NRf>	Set the IAI mode current limit. This is soft limit for the current. . After power up or *RST or RST<n> the limit for the IAI current will be set to maximum current rating of the unit (30 for High power active load and 15 for low power active load).
:LIMit?	Query the soft limit for the current
:EXTeRnal?	Query the control input mode of the Load Module. 1 means IAI mode, and 0 means SCPI mode.
:MODE?	Returns 1 for Constant Current, or 0 for Resistance Mode

5.9 SOURCE SCPI COMMANDS

5.9.1 SOURCE SCPI COMMAND SUMMARY

```

SOURCE<n>
  :CURRent < NRf >
  :CURRent?
    :PROTection <NRf>
    :PROTection?
      :DELAy <NRf>
      :DELAy?
    :RESistance < NRf >
    :RESistance?
  :VOLTage
    :PROTection <NRf>
    :PROTection?
  :POWer
    :PROTection <NRf>
    :PROTection?
      :DELAy <NRf>
      :DELAy?

```

5.9.2 SOURCE SCPI COMMAND REFERENCE

Command	Description
SOURCE<n>	SOURCE subsystem of commands
:CURRent <NRf>	Sets the input DC current setpoint in Amps. The range of the current setpoint is 0A to 30.1A in high power units and 0A to 15.05A in low power units. Default current setpoint is 0A. Current setpoint takes effect as soon as the command is sent. The Reset command sets the current setpoint to the default value.
:CURRent?	Returns the most recently set current setpoint.
:PROTection <NRf>	Set the overcurrent protection limit. The range of the current protection setpoint is 5% to 100% of Default. Default over current protection limit is 31.5A in high power units and 15.75A in low power units. The over current protection limit takes effect as soon as the command is sent. The Reset command sets the over current protection to the default value.
:PROTection?	Returns the most recently set overcurrent protection limit
:DELAy <NRf>	Set the over current protection delay timer in mSec. The range for the delay time is 1 to 100mSec. Default delay time is 100mSec. Delay time takes effect as soon as the command is sent. The Reset command sets the delay time to the default value.
:DELAy?	Returns the most recently set over current protection delay time.
:RESistance?	Returns the most recently set resistance setpoint.
:RESistance <NRf>	Sets the input resistance setpoint, range from 1 to 5,000 Ω's..
:VOLTage <NRf>	Sets the input voltage setpoint.
:PROTection <NRf>	Set the over voltage protection limit
:PROTection?	Returns the most recently set over voltage protection limit
:POWer	Power Protection subsystem commands

Command	Description
:PROTection <NRf>	Set the Power protection limit
:PROTection?	Query the Power protection limit
:DElAY <NRi>	Set the power protection delay time in mSec. The range for the delay is 1 to 100mSec. Default delay time is 1mSec Delay time takes effect as soon as the command is sent. The Reset command sets the delay time to the default value.
:DElAY?	Returns the value of the Power protection delay time.

5.10 STATUS SCPI COMMANDS

5.10.1 STATUS SCPI COMMAND SUMMARY

```

STATus<n>
  :MODule
    :ENABles <0+NR1>
    :ENABles?
    :FAULts?
    
```

5.10.2 STATUS SCPI COMMAND REFERENCE

Command	Description
STATus<n>	STATUS subset of SCPI commands.
:MODule	
:ENABles<0+NR1>	Enable the supervisory see Table 5-2.
:ENABles?	Query the enabled supervisories
:FAULts?	Query the module faults

Table 5-2. Enable Register

Bit	Hex Value	Mnemonics	Description
0	0x00000001	PRST	Power On Reset
1	0x00000002	FLS	Module Fault Latch Set
2	0x00000004	GPRF	Group Fault
3	0x00000008	MDENA	Module Front Panel Enable
4	0x00000010	BCKRI	Backplane Remote Inhibit
5	0x00000020	OVP	Over Voltage Protection Fault
6	0x00000040	ROVP	Redundant Over current Fault
7	0x00000080	UVP	Under Voltage Protection Fault
8	0x00000100	OCP	Over current Fault
9	0x00000200	ROCP	Redundant Over current Fault
10	0x00000400	RSF	Remote Sense Fault
11	0x00000800	ITOPP	Input Transient Overpower Protection
12	0x00001000	NEGPOL	Input Negative Polarity Voltage
13	0x00002000	REVOVP	Input Reverse Over voltage
14	0x00004000	AMA;PG	Analog Fault
15	0x00008000	PIOPP	Program Over Power Protection
16	0x00010000	IOTP	Internal Impending Over temperature
17	0x00020000	OTP	Internal Over temperature
18	0x00040000	AFF	Airflow Fault
19	0x00080000	UV5V	5V Housekeeping Supply Under voltage
20	0x00100000	OV5V	5V Housekeeping Supply Over voltage
21	0x00200000	UV14PT2V	14.2V Housekeeping Supply Under voltage
22	0x00400000	OV14PT2V	14.2V Housekeeping Supply Over voltage
23	0x00800000	UVNEG15V	-15V Housekeeping Supply Under voltage
24	0x01000000	OVNEG15V	-15V Housekeeping Supply Over voltage
25	0x02000000	GNDF	Paralleling Ground Fault
26	0x04000000	OCLF	Outer Control Loop Fault
27	0x08000000	ICLF	Inner Control Loop Fault
28	0x10000000		RESERVED
29	0x20000000		RESERVED
30	0x40000000		RESERVED
31	0x80000000		RESERVED

5.11 SYSTEM SCPI COMMANDS

5.11.1 SYSTEM SCPI COMMAND SUMMARY

```

SYSTEM
  :GROup
    :DEFine
      :PARallel <n,...,n>
    :DELete <NRi>
    :DELETE:ALL
  :ERRor?
    
```

5.11.2 SYSTEM SCPI COMMAND REFERENCE

Command	Description
SYSTEM	SYSTEM subsystem of commands.
:GROup	Group mode
:DEFine	Used to initially establish groups
:PARallel <n,...,n>	<p>Sets the modules to be paralleled.</p> <p>Rules:</p> <p>The first (and always the lowest) number in the argument is the address of the module that will act as master.</p> <p>The second number (and subsequent numbers) in the argument is (are) the address(es) of the module(s) that will act as slave(s).</p> <p>Each module's address is the right most slot that it occupies in a mainframe. (The slots of the mainframe are addressed 1 through 12 from left to right). HPAL and LPAL are 3U-wide, thereby occupying 3 slots; hence, a Load module occupying slots 1, 2 and 3, is addressed as 3.</p> <p>Valid argument examples:</p> <ul style="list-style-type: none"> • Two modules occupying slots 1 through 3 and 4 through 6: <3,6>. Address 3 is the master of this group; address 6 is the slave of this group. • Three Load modules occupying slots 1 through 3, 4 through 6 and 10 through 12: <3,6,12>. Address 3 is the master of this group; addresses 6 and 12 are the slaves of this group. Slots 7 through 9 must remain empty.

	<p>The module acting as master accepts SCPI commands for the group. The current and/or resistance set points for the parallel group will be set to zero (0) and one (1) respectively, and the output relays will be open (if option selected), as a part of setting up a group. The paralleled group is named 1000+n where n is the address of the module acting as master of the group.</p> <p>Additional notes: Only like-modules can be paralleled (i.e., either High Power Active Loads or Low Power Active Loads, in this case). Modules in a group may be in noncontiguous slots of the Mainframe, but other modules must not be installed in the empty slots between them.</p>
<p>:DELEte <NRi></p>	<p>Delete the specific group of modules, i.e., 1000+n where n is the master of the group.</p>
<p>:DELEte:ALL</p>	<p>Deletes any and all the groups in the RFP system</p>
<p>:ERRor?</p>	<p>Returns the last error logged in the Error/Event Queue. The message, "0, No error", is returned if there are no errors.</p>

SECTION 6

FIXED POWER DC REMOTE PROGRAMMING

6.1 INTRODUCTION

This section covers the remote programming option for the ReFlex Power™ Fixed Power DC Module. This interface enables operation of the Fixed Power DC from a computer via the Ethernet, allowing full remote programming control and monitoring of the Fixed Power DC module.

6.2 FEATURES AND FUNCTIONS

FEATURES

- Fixed Plus 5, Minus 5, Plus 15 and Minus 15 Volt Supply
- SCPI compliant command set
- Fixed Voltage Output
- Field-upgradeable firmware via Ethernet
- Soft calibration

PROGRAMMABLE FUNCTIONS

- Over/Undervoltage protection
- Output enable/disable
- Maskable fault interrupt
- Full calibration

READBACK FUNCTIONS

- Status and Accumulated Status registers
- Programming error codes
- Fault codes
- Manufacturer, power supply model, serial number, and firmware version identification

6.2.2 POWER-ON CONDITIONS

Table 6-1 presents remote power-on conditions for the Fixed Power DC.

Table 6-1. Remote Power-on Conditions

Parameter	Default Power-on Condition
Voltage	$\pm 15, \pm 5$ Volts (initial power-on voltage).
OVP Trip Voltage	Model maximum voltage +15% (initial power-on OVP).
Output	On, if module enable is present.

6.3 ERROR CODES

The error codes exist in the range of [-32768, 32767]. SCPI reserves the negative error codes and zero, while the error codes greater than zero and in the range of -399 to -300 are defined as device-specific. The negative error codes in the range of -499 to -100 are standardized errors that are reported in the Standard Event Status Register and the Error/Event Queue. The error codes that are stored in the Error/Event Queue are read with the `SYSTEM:ERROR?` query.

6.3.1 SCPI ERROR CODES

The following error codes are defined by the SCPI Standard 1999.0, and are supported by the ReFlex Power™ FPDC.

0, No error

The error queue is empty.

-102, Syntax error

Message returned: SYNTAX_ERROR: -102. An unrecognized command or data type was encountered.

-200, Execution error

Message returned: EXEC_ERROR: -200. Command could not be executed.

-222, Data out of range

Message returned: DATA_OUT_OF_RANGE: -222. An out-of-range command parameter had been entered.

-350, Queue overflow

The Error/Event Queue could contain up to ten entries. If more than 10 error/event conditions are logged before the `SYSTEM:ERROR?` query, an overflow will occur; the last queue entry will be overwritten with error -350. When the queue overflows, the least recent error/event remains in the queue and the most recent error/event is discarded.

6.3.2 ERROR/EVENT QUEUE

The Error/Event Queue is a FIFO (First-In-First-Out) buffer for storing detected errors. When the queue is read with the `SYSTem:ERRor?` query, the error that was detected first will be read first, and the error that was detected last will be read last. When all errors are read, the message “**0, No error**” will be returned. Up to 10 errors can be stored before overflow would occur. Overflow will result in error code -350, “Queue overflow” overwriting the last entry. All subsequent errors will be ignored until the queue is read, and space is again available.

6.4 COMMON SCPI COMMANDS

The following commands are common to all SCPI instruments, and are mandatory for conformance to IEEE 488.2. In the following table, the ReFlex Power™ Active Load (AL) will be defined as the “device” on the bus.

Command	Description
*CLS	Clears all status reporting data structures including the Status Byte, the Standard Event Status Register, the Protection Event Status Register, and the Error Queue. Enable registers are not cleared by this command.
*IDN<n>?	Identification Query: Returns the device identity as an ASCII string: <manufacturer>,<model>,<serial number>,< firmware version>. Example: ELGAR,RFP-F1000-001-0000,0921A00746,3.000.001
*OPC<n>?	Operation Complete Query: Returns the integer value “1” when all pending operations are complete.
*RST<n>	Reset Command: Resets the device to the following state: 1. Output disabled, relays open. 2. Clears all status reporting data structures, including the Status Byte Register, Standard Event Status Register, and Error/Event Queue. Enable-masks are not cleared.
*TST<n>	Initiate self test
*TST<n>?	Returns the results from the last self test the module performed. Returns a decimal value, convert to Hex because more than one bit can be set.

6.5 CALIBRATION SCPI COMMANDS

CAUTION



Before attempting to execute any of the Fixed Power DC calibration commands, follow the calibration procedures in the ReFlex Power™ Operation Manual (M380056-01), Fixed Power DC Section. If calibration is not performed properly, functional problems could arise, preventing the ReFlex Power™ Fixed Power DC supplies from operating properly. Qualified personnel who are appropriately trained to deal with attendant hazards must perform calibration.

6.5.1 CALIBRATION SCPI COMMAND SUMMARY

```

CALibrate<n>
  :UNLock <string>
  :STORE
  :LOCK
  :POSitive15 <0+NR1>
  :POSitive15?
  :POSitive5 <0+NR1>
  :POSitive5?
  :NEGative15 <0+NR1>
  :NEGative15?
  :NEGative5 <0+NR1>
  :NEGative5?
  :MODule:LASTCAL <Date>
  :MODule:LASTCAL?
  :MODule:NEXTTCAL <Date>
  :MODule:NEXTTCAL?

```

6.5.2 CALIBRATION SCPI COMMAND REFERENCE

Command	Description
CALibrate<n> ¹	CALIBRATE sub-commands
:UNLock <string>	Enables the EEPROM memory for storing calibration constants. The enable string is <"6867">.
:STORE	Stores the calibration constants in the EEPROM memory.
:LOCK	Disables access to the EEPROM memory, thereby preventing storing of calibration constants.
:POSitive15 <0+NR1>	Calibration for Positive 15 DC supply. Value is between 0 to 255
:POSitive15?	Query the pot setting
:POSitive5 <0+NR1>	Calibration for Positive 5 DC supply. Value is between 0 to 255
:POSitive5?	Query the pot setting
:NEGative15 <0+NR1>	Calibration for Negative 15 DC supply. Value is between 0 to 255
:NEGative15?	Query the pot setting
:NEGative5 <0+NR1>	Calibration for Negative 5 DC supply. Value is between 0 to 255
:NEGative5?	Query the pot setting
:MODule	
:LASTCAL <Date>	Set the last calibration date
:LASTCAL?	Query the last calibration date
:NEXTTCAL <Date>	Set the next calibration date
:NEXTTCAL?	Query the next query calibration date.

¹ Calibration is required to be run twice, once with Sense relays closed and with Sense relays open, then Store the calibration constants,

6.6 OUTPUT SCPI COMMANDS

6.6.1 OUTPUT SCPI COMMAND SUMMARY

```

OUTPut<n>
  :STATe <bool>
  :STATe?
  :ISOLation?
  :SENSE <bool>
  :SENSE?

```

6.6.2 OUTPUT SCPI COMMAND REFERENCE

Command	Description
OUTPut<n>	OUTPUT subsystem of commands
:STATe <bool>	Turns the output On or Off. Valid arguments are 1/On (Output On) or 0/Off (Output Off).
:STATe?	Returns the state of the Output, 1 = On, or 0 = Off.
:ISOLation?	Returns the state of the ISOL relay, Open if Output is off.
:SENSE <bool>	Opens/Closes the SENSE relay.
:SENSE?	Returns the state of the SENSE relay

6.7 STATUS COMMANDS

6.7.1 STATUS SCPI COMMAND SUMMARY

```

STATus<n>
  :MODule
    :ENABles <0+NR1>
    :ENABles?
    :FAULts?
    :HWREV?

```

6.7.2 STATUS SCPI COMMAND REFERENCE

Command	Description
STATus<n>	STATUS subsystem of commands..
:MODule	
:ENABles<0+NR1>	Enable the supervisory see Table 6-2. Same Table should be used for the Fault queries
:ENABles?	Query the enabled supervisories
:FAULts?	Query the module faults
:HWREV?	Returns Module type and Hardware Revision

Table 6-2. Faults / Enable Register

Bit	Hex Value	Mnemonics	Description
0	0x00000001	P5VF	Plus 5 Volt Fault
1	0x00000002	M5VF	Minus 5 Volt Fault
2	0x00000004	P15VF	Plus 15 Volt Fault
3	0x00000008	M15VF	Minus 15 Volts Fault
4	0x00000010	OTP	Over Temperature Fault
5	0x00000020	5VSNSF	5 Volt House Keeping Sense Fault
6	0x00000040	12VSNSF	12 Volt House Keeping Sense Fault
7	0x00000080	POROK	Power Ok Fault

6.8 SYSTEM COMMANDS

6.8.1 SYSTEM SCPI COMMAND SUMMARY

SYSTem
:ERRor?

6.8.2 SYSTEM SCPI COMMAND REFERENCE

Command	Description
SYSTem	SYSTEM subsystem of commands.
:ERRor?	Returns the last error logged in the Error/Event Queue. The message, "0, No error", is returned if there are no errors.