



*160 Series, 180 Series
DC Power Supplies*

**IEEE 488.2 Option
Programming Manual**

PowerTen
9250 Brown Deer Road
San Diego, CA 92121-2294
1-800-733-5427
Tel: (858) 450-0085
Fax: (858) 458-0267
Email: sales@elgar.com
www.elgar.com

©2002 by PowerTen. This document contains information proprietary to PowerTen. The information contained herein is not to be duplicated or transferred in any manner without prior written permission from PowerTen.

Safety Notice

Before applying power to the system, verify that the unit is configured properly for the user's particular application.

CE and UL recognition status of this series of power supplies is based on rack mounted application only. Use of the power supplies outside of a rack mount enclosure will expose the user to high voltage and/or high current sources. Extreme caution must be used under these circumstances.

The analog control inputs (connectors J1 and J2) on the rear panel are referenced to the negative output of the power supply. Grounding the positive output of the power supply or biasing the output of the supply above chassis potential will cause these inputs (along with the output of the supply) to have a potentially hazardous offset voltage. Exercise caution under these conditions. Under no circumstances should the output of the supply be biased more than 500 volts from chassis potential.

Installation and service must be performed only by properly trained and qualified personnel who are aware of dealing with attendant hazards. This includes simple tasks such as fuse verification.

Ensure that the AC power line ground is connected properly to the unit input connector or chassis. Similarly, other power ground lines including those to application maintenance equipment must be grounded properly for both personnel and equipment safety.

Always ensure that facility AC input power is de-energized prior to connecting or disconnecting the input/output power cables.

Warning: Lethal voltages may be present inside the power supply even when the AC input voltage is disconnected. Only properly trained and qualified personnel should remove covers and access the inside of the power supply.

During normal operation, the operator does not have access to hazardous voltages within the chassis. However, depending on the user's application configuration, HIGH VOLTAGES HAZARDOUS TO HUMAN SAFETY may be generated normally on the output terminals. Ensure that the output power lines are labeled properly as to the safety hazards and that any inadvertent contact with hazardous voltages is eliminated.

Due to filtering, the unit has high leakage current to the chassis. Therefore, it is essential to operate this unit with a safety ground.

This unit is designed to be permanently connected to the power source and as such must have a readily accessible disconnect device incorporated in the fixed wiring.

After the unit has been operating for some time, the metal near the rear of the unit may be hot enough to cause injury. Let the unit cool before handling.

These operating instructions form an integral part of the equipment and must be available to the operating personnel at all times. All the safety instructions and advice notes are to be followed.

Neither Power Ten nor any of the subsidiary sales organizations can accept responsibility for personal, material or consequential injury, loss or damage that results from improper use of the equipment and accessories.

SERVICE SAFETY NOTICES

WARNING!

HAZARDOUS VOLTAGES IN EXCESS OF 480 V RMS, 700 V PEAK MAY BE PRESENT WHEN COVERS ARE REMOVED. QUALIFIED PERSONNEL MUST USE EXTREME CAUTION WHEN SERVICING THIS EQUIPMENT. CIRCUIT BOARDS, TEST POINTS, AND OUTPUT VOLTAGES MAY BE FLOATING ABOVE CHASSIS GROUND.

WARNING!

TO GUARD AGAINST RISK OF ELECTRICAL SHOCK DURING OPEN COVER CHECKS, DO NOT TOUCH ANY PORTION OF THE ELECTRICAL CIRCUITS. EVEN WHEN THE POWER IS OFF, CAPACITORS CAN RETAIN AN ELECTRICAL CHARGE. USE SAFETY GLASSES DURING OPEN COVER CHECKS TO AVOID PERSONAL INJURY BY ANY SUDDEN FAILURE OF A COMPONENT.

WARNING!

SOME CIRCUITS ARE LIVE EVEN WITH THE FRONT PANEL SWITCH TURNED OFF. SERVICE, FUSE VERIFICATION, AND CONNECTION OF WIRING TO THE CHASSIS MUST BE ACCOMPLISHED AT LEAST FIVE MINUTES AFTER POWER HAS BEEN REMOVED VIA EXTERNAL MEANS; ALL CIRCUITS AND/OR TERMINALS TO BE TOUCHED MUST BE SAFETY GROUNDED TO THE CHASSIS.

WARNING!

QUALIFIED SERVICE PERSONNEL NEED TO BE AWARE THAT SOME HEAT SINKS ARE NOT AT GROUND, BUT AT HIGH POTENTIAL.

FCC NOTICE

This equipment has been tested and found to comply with the limits for a Class A digital device, pursuant to part 15 of the FCC Rules. These limits are designed to provide reasonable protection against harmful interference when the equipment is operated in a commercial environment. This equipment generates, uses, and can radiate radio frequency energy and, if not installed and used in accordance with the instruction manual, may cause harmful interference to radio communications. Operation of this equipment in a residential area is likely to cause harmful interference in which case the user will be required to correct the interference at his own expense.

DECLARATION OF CONFORMITY

We:

Power Ten
9250 Brown Deer Road
San Diego, CA 92121-2294

declare under our sole responsibility that the product:

all 'I' series models except 600V output

are in conformity with the following standards or other normative documents:

CE Mark (Commercial/Light Industrial)

Radiated Emissions	EN55011A	
Conducted Emissions	EN55011A	
Electrostatic Discharge	EN61000-4-2	4kV contact
	EN50082-2 (1995)	8kV air
Radiated Susceptibility	ENV50140	
	EN50082-2 (1995)	10V/m
Conducted Susceptibility	ENV50141	10V rms
	EN50082-2 (1995)	
Electrical Fast Transient Burst	EN61000-4-4	2kV (A/C)
	EN50082-2 (1995)	1kV (I/O)
Low Voltage Directive	EN60950 : 1992+A1+A2+A3 (TUV cert)	

following the provisions of IEC 89/336/EEC directive.

June 25, 1999

John Baker
Manager, Quality Assurance



About This Manual

This manual has been written expressly for the Power Ten "I" Series of power supplies which have been designed and certified to meet the 1997 Low Voltage and Electromagnetic Compatibility Directive Requirements of the European Community. All units in this series comply with these directives.

Since the Low Voltage Directive is to ensure the safety of the equipment operator, universal graphic symbols (see below) have been used both on the unit itself and in this manual to warn the operator of potentially hazardous situations.

SAFETY SYMBOLS

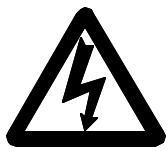

CAUTION
Risk of Electrical Shock

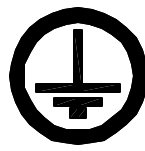

Protective Conductor Terminal



CAUTION
Refer to Accompanying Documents



Alternating Current (AC)

TABLE OF CONTENTS

WHILE IN WORD OR VIEWER CLICK ON PAGE NUMBER TO JUMP TO PAGE

Chapter 1 DESCRIPTION OF EQUIPMENT	1-1
1.1 PURPOSE AND CAPABILITIES	1-1
1.2 TECHNICAL CHARACTERISTICS	1-1
Chapter 2 OPERATING INSTRUCTIONS	2-1
2.1 IEEE 488.2 command set	2-1
2.2 IEEE 488.2 FUNCTIONal description	2-5
Chapter 3 CALIBRATION	3-1
3.1 CALIBRATION AND ADJUSTMENTS	3-1

LIST OF FIGURES

FIGURE 3-3 ADDRESS SWITCH.....	2-4
FIGURE 3-4 BLOCK DIAGRAM OF HARDWARE CONFIGURATION.....	2-6

LIST OF TABLES

TABLE 1-1 SERIES I62, I63 AND I66 TECHNICAL CHARACTERISTICS	1-2
---	-----

Chapter 1

DESCRIPTION OF EQUIPMENT

1.1 PURPOSE AND CAPABILITIES

The Power Ten I60 Series power supplies are general purpose power supplies designed specifically for laboratory test and systems applications requiring variable DC sources with good ripple and regulation characteristics. The I62, I63 and I66 Series are IEEE versions of Power Ten's P62, P63 and P66 Series. The power supplies of each series are constant current constant voltage supplies with an automatic crossover feature. The I62 Series models provide up to 3000 watts, the I63 models up to 10 kilowatts, and the I66 models up to 20 kilowatts, each over a wide range of voltage and current levels.

1.2 TECHNICAL CHARACTERISTICS

The characteristics for the IEEE aspects of the I62, I63 and I66 Series are listed in Table 1-1.

Table 1-1
Series I62, I63 and I66 Technical Characteristics

PARAMETERS	SPECIFICATIONS												
REMOTE CONTROL - IEEE 4888.2	<table style="margin-left: auto; margin-right: auto;"> <thead> <tr> <th></th> <th style="text-align: center;"><u>Resolution</u></th> <th style="text-align: center;"><u>Accuracy</u></th> </tr> </thead> <tbody> <tr> <td>Voltage</td> <td></td> <td style="text-align: center;">±0.03%</td> </tr> <tr> <td>±0.1%</td> <td></td> <td></td> </tr> <tr> <td>Current</td> <td style="text-align: center;">±0.03%</td> <td style="text-align: center;">±0.1%</td> </tr> </tbody> </table>		<u>Resolution</u>	<u>Accuracy</u>	Voltage		±0.03%	±0.1%			Current	±0.03%	±0.1%
	<u>Resolution</u>	<u>Accuracy</u>											
Voltage		±0.03%											
±0.1%													
Current	±0.03%	±0.1%											
Data Rate	1 M byte/second												
Interconnection Path	Star daisy chain or linear network												
Cable Length	2 Meters per device (max.)												
ELECTRICAL CHARACTERISTICS:													
Data-Transfer Format	Byte-serial, bit-parallel using asynchronous 3-wire handshakes												
Primary Address	31 TALK, 31 LISTEN												
Maximum Devices	1 Talker and 14 Listeners at one time												
Remote Sensing	Terminals are provided to sense output voltage at point of load.												

Chapter 2

OPERATING INSTRUCTIONS

2.1 IEEE 488.2 COMMAND SET

Below are two lists of commands: (1) Programmable Set Functions which can be sent to the GPIB power supply, and (2) Readback Functions which enable the available data to be read back.

Programmable Set Functions

Output On/Off
Set Output Voltage
Set Output Current
Maximum Rated Voltage
Maximum Rated Current
Wait to Complete Operation
Reset power Supply State

Readback Functions

Actual Voltage
Actual Current
Read ID
 Read Status Register
 Read Operation Complete
Self-Test Error Code

All IEEE 488.2 programmable common routines can be categorized under the following headings.

1. Simple Device I/O

Send
Receive

2. Multiple Device I/O

Sendlist

3. Simple Device Control

Device Clear
Read Status Byte

In addition to the IEEE 488.2 routines and functions, Power Ten power supplies respond to the following common commands and queries.

Command Mnemonics	Description
CST ON	Controls the ON state of the power supply. The response is "ST ON."
CST OFF	Controls the OFF state of the power supply. The response is "ST OFF."

Command Mnemonics	Description
SRVT xx.xxx	Sets the power supply output at the maximum rated voltage. This command must be stated prior to WVA xx.xxx and WCA xx.xxx.
SRCT xx.xxx	Sets the power supply output current at the maximum rated current. This command must be stated prior to WVA xx.xxx and WCA xx.xxx.
WVA xx.xxx WCA xx.xxx	Sets the output voltage/current from 00.00 up to maximum rating.
*WAI	Forces the controller to complete all pending operations.
*RST	Clears the standard event status register and initializes the GPIB interface controller.
RVA	Reads the actual power supply output voltage. The response is VA xx.xxx.
RCA	Reads the actual current output by the power supply. The response is CA xx.xxx.
*IDN?	Commands controller to send its identity string. The response is: Power Ten Series No.
*CLS	Clears both the standard event status and serial POLL status registers.
*ESE?	Commands the controller to send the content of the standard event status enable register.
*ESE XXX	Sets the standard event status enable register to a new value. XXX is a decimal string between 0 and 255.
*ESR?	Directs controller to send the last command sent to the power supply. The controller clears the ESB bit in the status byte.
*SRE?	Directs the controller to send the last command sent to the controller.
*SRE XXX	Sets status enable register to new value.

Command Mnemonics	Description
*STB?	Directs the controller to send the byte from status register. This byte can also be read by using the Serial POLL command.
*OPC?	Directs controller to send the status of the operation complete bit in the standard event status register. The response is 1.
*OPC	Sets the status of the operation complete bit in the standard event status register TRUE. If proper bits in the standard event enable and status enable registers are set, an SRQ is issued to the controller.

The IEEE 488.2 Address Switch is located on the rear panel, next to the IEEE 488.2 connector. The address switch, see Figure 3-3, is an nine bit DIP-switch with the function as explained below:

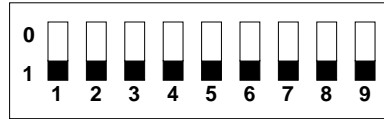

- | | | | |
|----|---------------|---|-----------------|
| 1. | Address bit 1 | 6 | Not Used |
| 2. | Address bit 2 | 7 | Not Used |
| 3. | Address bit 3 | 8 | Not Used |
| 4. | Address bit 4 | 9 | Local/IEEE Mode |
| 5. | Address bit 5 | | |

Figure 2-1
Address Switch

The position of the first five switches determines the GPIB address of the power supply. The address switch has five binary weighted positions (1, 2, 4, 8, 16). The desired address is selected by turning on or off different combinations of switches. The address switch register is read by the microprocessor upon power-up. For example, address 1 is bit 0-on, and all other bits off.

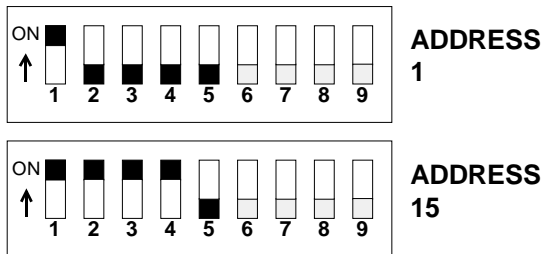

The 9th bit of the DIP-switch (S1), located on the rear panel, places the power supply in the IEEE mode. The power supply must be OFF when switching from one mode to the other.

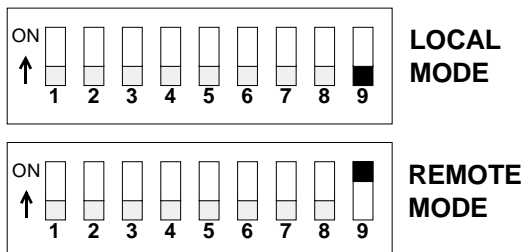

2.2 IEEE 488.2 FUNCTIONAL DESCRIPTION

The IEEE 488.2 parallel interface controller in Power Ten power supplies complies with IEEE 488.2-1987 protocols and IEC 625 standards. The controller is compatible with all A-488.2 interface functions, such as, Source Handshake (SH1), Acceptor Handshake (AH1), Basic Talker (T6), Basic Listener (L4), Service Request (SR1), Remote Local (RL1), Parallel Poll (PP1), Controller in Charge (CIC), Electrical Interface E1 (Open Collector).

Functional Description.

Microprocessor

This block consists of the INTEL 8085, the 10 MHz crystal oscillator and power-up reset circuitry. See Figure 3-4 for a block diagram of the hardware configuration. The 8085 will divide the 10 MHz oscillator by 2 and run at 5 MHz. A 5 MHz clock is output from the chip for use in other circuits. In this design it is connected to the 9914A (GPIB controller chip). The resistor and capacitor provide the power-up reset pulse. This is also conditioned by the 8085 and provided as a CMOS compatible output.

Latch

The latch is used to capture the upper 8 bits using the ALE control signal provided by the microprocessor. These upper 8 bits are combined with the lower 8 bits of the address bus provided from the 8085.

EPROM and RAM

The EPROM and RAM circuitry receive address information from the CAXX bus and interface directly with the 8085 ADX bus. The upper bits of the address bus are decoded by the micro address decode block. This block provides chip select lines and read/write control lines to the system memory (EPROM and RAM). The EPROM is located at addresses 0000H through 3FFFH. On power-up (after reset), the microprocessor starts executing instructions found at address 0000H. The RAM addresses (16k bytes) are located in the upper part of the address space (C000H to FFFFH).

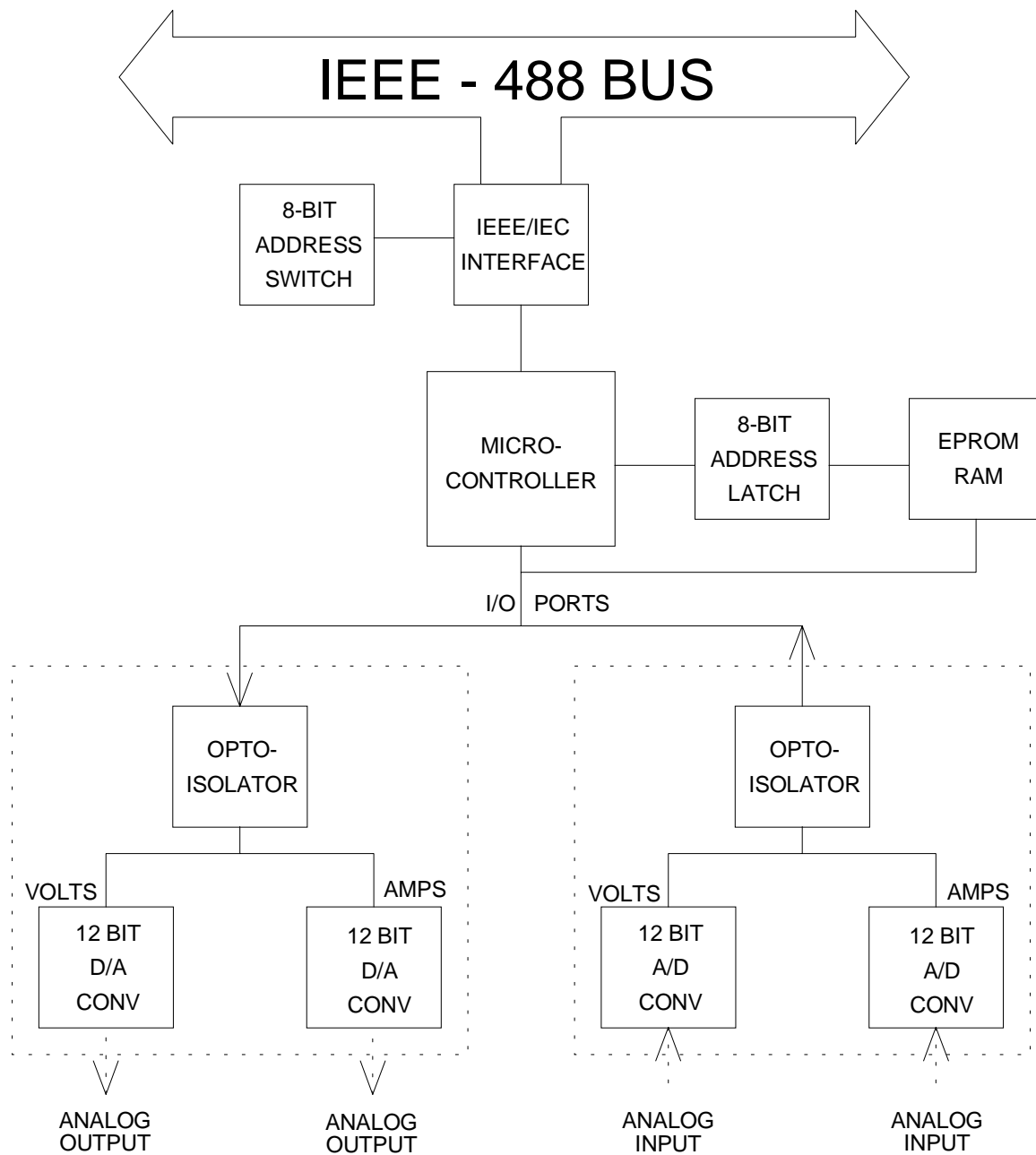

Figure 2-2
Block Diagram of Hardware Configuration

Chapter 3

CALIBRATION

3.1 CALIBRATION AND ADJUSTMENTS

To perform the following calibration and adjustment procedures, the cover must be removed from the power supply. Because removal of the cover allows access to potentially hazardous power voltages (up to 253 VAC or 450 VDC) and because of the importance of accurate readings to performance, only technically trained personnel should perform calibration procedures.

WARNING

Hazardous voltages are present inside the unit even after disconnection of power. Disconnect power cord from power source and allow a minimum of 5 minutes for discharge of stored energy before removing the cover or performing any maintenance function.

The calibration Test Setup procedures require the following: remove prime power, then connect the power supply to a resistive load capable of full-rated voltage and current. Connect a precision current shunt in series with either the positive or negative output between the power supply and the resistive load. Two digital multimeters are required to perform the calibration procedures.

I62 and 63 Series Calibration Procedures

5V Reference Calibration

The 5V reference for the front panel voltage and current control must be calibrated first.

1. With prime power removed, remove jumper J9/P9 on the converter assembly.
2. Connect a digital multimeter (DMM) between E1 and E3 of the current control potentiometer R32 on the control assembly.
3. Apply prime power to the power supply.
4. Adjust potentiometer R29 until DMM across E1 and E3 indicates 5.000 VDC.
5. Remove prime power from power supply and wait 3 minutes (minimum) for filter capacitors to discharge.

I62/I63/I66 Calibration

The I62, I63 and I66 Series calibration is performed following the control/converter calibration in the local mode (see the operator and maintenance manual for the Series P60 and D3).

Current Calibration.

1. Place the power supply in the IEEE mode by turning on the 9th position of the DIP-switch on the rear panel of the unit.
2. Set the power supply to the proper address switch. Refer to IEEE 488.2 section of the manual for the proper selection of the address switch.
3. Apply prime power to the power supply.
4. Connect a DMM across the external current shunt.
5. Place the Power supply in the current mode via the GPIB BUS, i.e., the command WVA xx.xxx is set to maximum rating and WCA xx.xxx is set to 00.000.
6. Adjust R31 potentiometer on the IEEE circuit board for zero null current calibration (minimum voltage on the DMM).
7. Set the output current of the power supply to maximum rating by setting the command WCA xx.xxx to full-scale rating while monitoring the current across the external shunt.
8. Adjust R33 potentiometer on the IEEE circuit board until the DMM indicates that the current across the external shunt is at full-rated output.

Voltage Calibration.

1. Place the power supply in the voltage mode by setting the command WVA xx.xxx to 00.000 and WCA xx.xxx to maximum current rating.
2. Connect DMM across the output terminals of the power supply or across Vsns+ and Vsns- of the D-shell (pin 13 and 12 of J1) on the rear panel.
3. Adjust R39 on the IEEE circuit board for zero null voltage calibration (minimum voltage on the DMM meter).
4. Set the output voltage of the power supply to maximum rating by setting command WVA xx.xxx to full-scale rating.
5. Adjust R41 potentiometer on the IEEE circuit board until the DMM with leads across the output terminal indicates full-rated voltage.

Full-Scale Current Readback Calibration

1. Place the power supply in the current mode via the GPIB command by setting WVA xx.xxx to maximum voltage rating and WCA xx.xxx to a desired value.
2. Connect a DMM across the external current shunt.
3. Set command WCA xx.xxx to maximum current rating while monitoring current across the external current shunt.
4. Send the current readback command RCA over the GPIB BUS.
5. Adjust potentiometer R51 on the IEEE circuit board until the current readback response matches the actual current across the external shunt to within 0.1 percent.

Full-Scale Voltage Readback Calibration

1. Place the power supply in the voltage mode via the GPIB Bus by setting WCA xx.xxx to maximum current rating and WVA xx.xxx to an arbitrary value.
2. Connect a DMM across the external output terminals of the power supply.
3. Set command WVA xx.xxx to maximum voltage rating while monitoring the output voltage.
4. Send the voltage readback command RVA over the GPIB BUS.
5. Adjust potentiometer R49 on the IEEE circuit board until the voltage readback response matches the actual output voltage of the power supply to within 0.1 percent.