

# POWER *TEN*

*3400 Series*  
*1kW & 2kW*  
*DC Power Supply*

***Operation and Maintenance***  
***Manual***

**\* REFERENCE ONLY \***

***\* OBSOLETE SERIES, NO LONGER SUPPORTED \****

**Elgar Electronics Corporation**

9250 Brown Deer Road

San Diego, CA 92121

1-800-733-5427

Tel: 858-450-0085

Fax: 858-458-0267

Email: [sales@elgar.com](mailto:sales@elgar.com)

[www.elgar.com](http://www.elgar.com)

©2004 Elgar Electronics Corporation. This document contains information proprietary to Elgar Electronics Corporation. The information contained herein is not to be duplicated or transferred in any manner without prior written permission from Elgar Electronics Corporation.

**WARNING**

Hazardous voltages (greater than 50 volts) may be present when cover is removed and could cause injury to personnel. Authorized personnel only should remove cover.

## TABLE OF CONTENTS

CHAPTER 1	DESCRIPTION OF EQUIPMENT Purpose and Capabilities Technical Characteristics
CHAPTER 2	INSTALLATION Inspection Input/Output Connectors Location and Mounting Checkout and Preliminary Adjustments
CHAPTER 3	OPERATING INSTRUCTIONS Controls and Indicators Setup and Operating Instructions Local Operation Remote Current Programming Remote Voltage Programming Remote Sensing Remote Output On/Off Control Auto-Parallel Operation Auto-Series Operation Auto-Tracking Operation
CHAPTER 4	PRINCIPLES OF OPERATION Introduction General Description Converter Assembly A1 Control Assembly A2 Top Assembly Detailed Circuit Description Top Assembly Converter Assembly A1 +12 V Bias Regulators +15 V Blower Bias Enable Circuit Thermal Detector Circuit Slow Start Circuit Pulse-width Limiter Circuit Pulse-width Modulator Basedrive Amplifiers Basedrive Circuits Converter Switch Transistors Control Assembly A2 Voltage Reference Circuit Current Reference Circuit Voltage Control Current Control Current Limit Current Monitor/Parallel Tracking Amplifier

**TABLE OF CONTENTS - Continued**

Remote On/Off Output Control  
Voltage/Current Mode Indicators  
Remote Interface

<b>CHAPTER 5</b>	<b>MAINTENANCE</b>
	Introduction
	Equipment Required
	Preventive Maintenance
	Repair
	Calibration and Adjustments
	Voltage Reference
	Current Reference
	Voltage Zero
	Current Zero
	Current Monitor/Parallel Tracking Amplifier
	Voltage Full Scale
	Meter Zero
	Meter Full Scale
<b>CHAPTER 6</b>	<b>LIST OF MATERIALS</b>
<b>CHAPTER 7</b>	<b>DRAWINGS</b>

## CHAPTER 1

### DESCRIPTION OF EQUIPMENT

#### 1-1. PURPOSE AND CAPABILITIES

The Power Ten, Inc. Series 3400 power supply is general purpose power supply designed specifically for laboratory test and systems applications requiring variable DC sources with good ripple and regulation characteristics. The Series 3400 power supply is a constant current/constant voltage power supply with an automatic crossover feature. It provides up to 2000 watts of DC power over a wide range of voltage and current levels.

#### 1-2. TECHNICAL CHARACTERISTICS

The physical, electrical and environmental characteristics for the Series 3400 are listed in Tables 1-1 and 1-2.

Table 1-1. Series 3400 Technical Characteristics

PARAMETERS	SPECIFICATIONS
<b>PHYSICAL CHARACTERISTICS</b>	
Width	19 in.
Depth	18.5 in.
Height	3.5 in.
Weight	30 lbs.
<b>ELECTRICAL CHARACTERISTICS</b>	
Input Power (std)	
Voltage	190-253 VAC <sup>1</sup>
Frequency	47 to 63 Hz
Phase	Single, 2 wire plus gnd
Regulation (Line or Load)	
Voltage	0.1% of max. output voltage.
Current	0.1% of max. output current.
Noise and Ripple (RMS)	30 mV max. (all Models except as noted in column 3 of table 1-2)
Transient Response	A 30% step load will recover to within 2% of final value within 10 ms.
Stability	±0.05% of set point for 8 hrs. after warm-up and at a fixed line, load and temperature.
Remote Control	On/Off control via contact closure, 6-120 VDC or 12-240 VDC.

<sup>1</sup>95-127 VAC available as option on selected models.

Table 1-1. Series 3400 Technical Characteristics - Continued

PARAMETERS	SPECIFICATIONS
<b>ELECTRICAL CHARACTERISTICS</b>	
Remote Programming	
Resistive:	
Constant Voltage(0-100%)	0 - 5K ohms
Constant Current(0-100%)	0 - 100 ohms
Voltage:	
Constant Voltage(0-100%)	0 - 5 VDC
Constant Current(0-100%)	0 - 100 mV
Current:	
Constant Voltage(0-100%)	0 - 1 mA
Constant Current(0-100%)	0 - 1 mA
Remote Sensing <sup>1</sup>	Terminals provided to sense output voltage at point of load.
<b>ENVIRONMENTAL CHARACTERISTICS</b>	
Temperature Coefficient	0.02%/deg. C of max. output voltage rating for voltage set point.  0.03%/deg. C of max. output current rating for current set point.
Ambient Temperature	
Operating	0 to 50 Degrees C
Storage	-40 to 75 Degrees C
Cooling	Forced Air Cooled

<sup>1</sup>Except in models in excess of 60 VDC output.

Table 1-2. 3400 Technical Characteristics

MODEL NO.	OUTPUT DC		OUTPUT RIPPLE (RMS)
	VOLTS	AMPS	
7.5250	0-7.5	0-250	30 mV
10200	0-10	0-200	30 mV
20100	0-20	0-100	30 mV
4050	0-40	0-50	30 mV
6030	0-60	0-30	30 mV
3003	0-300	0-3	100 mV
3006	0-300	0-6	100 mV
6001.5	0-600	0-1.5	200 mV
6003	0-600	0-3	200 mV
10010	0-100	0-10	100 mV

**CHAPTER 2**  
**INSTALLATION**

**2-1. INSPECTION**

Inspect the shipping carton for possible damage before unpacking the unit. Carefully unpack the equipment. Save all packing materials until inspection is complete. Verify that all items listed on the packing slips have been received. Visually inspect all exterior surfaces for broken knobs, connectors or meters. Inspect for dented or damaged exterior surfaces. External damage may be an indication of internal damage. If any damage is evident, immediately contact the carrier that delivered the unit and submit a damage report. Failure to do so could invalidate future claims.

**2-2. INPUT/OUTPUT CONNECTORS**

Table 2-1 lists all external connectors for the Series 3400.

**2-3. LOCATION AND MOUNTING**

The Series 3400 is intended for mounting in a standard 19-inch equipment rack. Four captive screws, two on each side of the front panel, are used to secure the unit in place. The unit is also suitable for workbench applications.

**2-4. CHECKOUT AND PRELIMINARY ADJUSTMENTS**

Follow the instructions in paragraph 3-2 for setup and operation of the equipment.

Table 2-1. Series 3400 Input/Output Connectors

CONNECTOR	FUNCTION	CONNECTS TO
<p>FL1 - AC  FL1 - AC  FL1 - GND</p> <p>Pos. Bus Bar  Neg. Bus Bar  GND Stud</p> <p>TB1</p>	<p>[ Prime Power Input</p> <p>Output Power</p> <p>Control Interface</p>	<p>190-253 VAC  47-63 Hz AC  Power Source</p> <p>User Load(s)</p> <p>See Table 3-2  For Description</p>

## CHAPTER 3

### OPERATING INSTRUCTIONS

#### 3-1. CONTROLS AND INDICATORS

Front panel controls and indicators for the Series 3400 is identified in Figure 3-1 with index numbers keyed to Table 3-1. Table 3-1 provides a description of all operator controls and indicators.

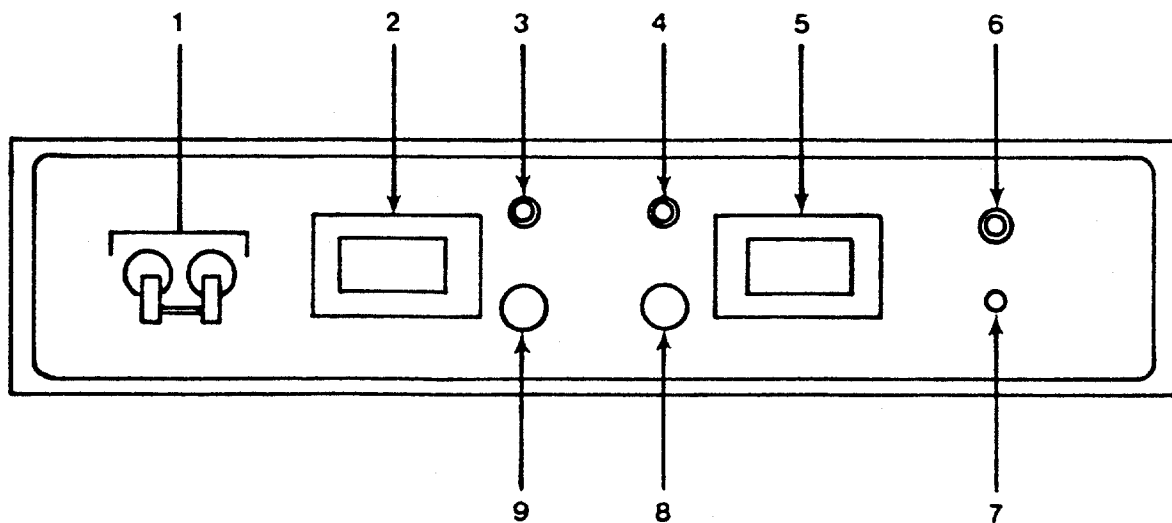

Figure 3-1. Series 3400 Controls and Indicators

## CHAPTER 3

### OPERATING INSTRUCTIONS

#### 3-1. CONTROLS AND INDICATORS

Front panel controls and indicators for the Series 3400 is identified in Figure 3-1 with index numbers keyed to Table 3-1. Table 3-1 provides a description of all operator controls and indicators.

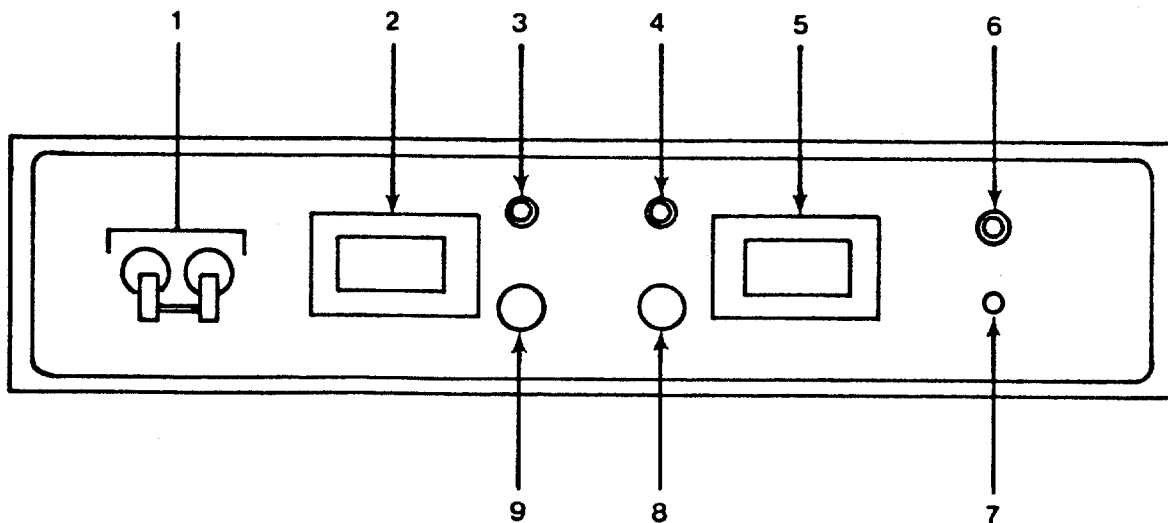

Figure 3-1. Series 3400 Controls and Indicators

Table 3-1. Series 3400 Controls and Indicators

FIGURE & INDEX NO.	CONTROL/INDICATOR	FUNCTION
3-1		
-1	Circuit Breaker	Applies AC power to the power supply.
-2	VOLTAGE Meter	Measures voltage output.
-3	Voltage Mode Indicator	Indicates the power supply is operating in the voltage mode.
-4	Current Mode Indicator	Indicates the power supply is operating in the current mode.
-5	CURRENT Meter	Measures current output.
-6	OVERVOLTAGE Indicator	Indicates output voltage has exceeded preset level, and power supply output is turned off.
-7	Overvoltage Potentiometer	Adjusts overvoltage trip level.
-8	Output Current Control	Adjusts current control to desired level.
-9	Output Voltage Control	Adjusts voltage output to desired level.

### 3-2. SETUP AND OPERATING INSTRUCTIONS

The following paragraphs provide setup and operating procedures for the Series 3400.

The power supply may be configured via TB1 for different operating configurations: local and remote current programming, local and remote voltage programming, normal parallel, auto-parallel, normal series, auto-series, and auto-tracking. The use and operating requirements of each configuration are provided in the following paragraphs. Reference Table 3-2 for barrier strip TB1 designators and functions.

a. Local Operation. Units are shipped from the factory configured for local voltage/current control and local voltage sensing. This configuration is used for applications where the IR drop of the load strapping pattern is provided in Figure 3-2. Prior to turning the unit on, rotate the voltage and current potentiometers fully counterclockwise (minimum output). Then switch the circuit breaker to the ON position and adjust the voltage and current to the desired output.

b. Remote Current Programming. The remote current programming configuration is used for applications that require the output current be programmed (controlled) from a remote source. An external resistance or external floating voltage source may be used for a programming device. When using remote current programming, a shielded, twisted pair hookup wire is recommended to prevent noise interference with programming signals.

(1) External Current Programming Using Resistance. The resistance coefficient for remote current programming is 100 ohms/100% rated output. The programming current from the current control programming terminal A3 is factory set for 1 milliampere. This yields a coefficient of 1% of rated output current per ohm (1%/ohm). If multiple switches or relays are used to program different levels, make-before-break contacts are recommended. See Figure 3-3 for strapping requirements.

(2) External Current Programming Using a Voltage Source. The voltage coefficient for remote current programming is 1 millivolt as depicted in the following examples.

<u>Model</u>	<u>Programming Coefficient</u>	<u>Full Scale Rated Output</u>
7.5-250	1 millivolt = 2.5 amps	100 mV
10-200	1 millivolt = 2.0 amps	100 mV
20-100	1 millivolt = 1.0 amps	100 mV
40-50	1 millivolt = 0.5 amps	100 mV
60-30	1 millivolt = 0.3 amps	100 mV

See figure 3-4 for strapping requirements.

Table 3-2. Barrier Strip (TB1) Designators and Functions

TB1 DESIGNATOR	SCHEMATIC SYMBOL	FUNCTIONAL DESCRIPTION
1 <sup>1</sup>	V+	Positive output voltage for local voltage sensing.
2 <sup>1</sup>	VS+	Positive voltage sensing terminal.
3	VPROG	1 milliamp current source for either local or remote voltage programming using resistance.
4	Vcont.	Voltage control input terminal.
5	Vset	Front panel voltage control potentiometers for local control.
6	VS-	Negative voltage sensing terminal.
7	V-	Negative output voltage for local voltage sensing.
8	Iprog.	1 milliamp current source for either local or remote current programming using resistance.
9	Icont.	Current control input terminal.
10	Iset	Front panel current control potentiometers for local control.
11	Imon-	Negative current monitor terminal. Return for remote current programming resistor.
12	Imon+	0-5 VDC = 0-100% rated current. User positive current monitor terminal or 0-1 milliamp auto-tracking control output terminal. Referenced to TB1-13.
13	On/Off contact return	Control Circuit Common. Used with TB1-12 for current monitor and/or TB1-14 for remote on/off ctrl rtn.

<sup>1</sup>Except in models in excess of 60 VDC output.

Table 3-2. Barrier Strip (TB1) Designators and Functions

TB1 DESIGNATOR	SCHEMATIC SYMBOL	FUNCTIONAL DESCRIPTION
1 <sup>1</sup>	V+	Positive output voltage for local voltage sensing.
2 <sup>1</sup>	VS+	Positive voltage sensing terminal.
3	VPROG	1 milliamp current source for either local or remote voltage programming using resistance.
4	Vcont.	Voltage control input terminal.
5	Vset	Front panel voltage control potentiometers for local control.
6	VS-	Negative voltage sensing terminal.
7	V-	Negative output voltage for local voltage sensing.
8	Iprog.	1 milliamp current source for either local or remote current programming using resistance.
9	Icont.	Current control input terminal.
10	Iset	Front panel current control potentiometers for local control.
11	Imon-	Negative current monitor terminal. Return for remote current programming resistor.
12	Imon+	0-5 VDC = 0-100% rated current. User positive current monitor terminal or 0-1 milliamp auto-tracking control output terminal. Referenced to TB1-13.
13	On/Off contact return	Control Circuit Common. Used with TB1-12 for current monitor and/or TB1-14 for remote on/off ctrl rtn.

<sup>1</sup>Except in models in excess of 60 VDC output.

Table 3-2. Barrier Strip (TB1) Designators and Functions - Continued

TB1 DESIGNATOR	SCHEMATIC SYMBOL	FUNCTIONAL DESCRIPTION
14	On/Off contact control	Remote on/off control using contacts of switch or relay.
15	On/Off AC/DC rtn	Return for AC/DC voltage source used for remote on/off control.
16	On/Off AC/DC	Externally supplied AC/DC voltage source for on/off output voltage control. This is a positive (+) terminal for DC voltage.

c. Remote Voltage Programming. The remote voltage programming configuration is used for applications that require the output voltage be programmed (controlled) from a remote source. An external resistance or external floating voltage source may be used a programming device. When using remote voltage programming, a shielded, twisted pair hookup wire is recommended to prevent noise interference with programming signals.

(1) External Voltage Programming Using Resistance. The resistance coefficient for remote voltage programming is 5k ohms = 100% of rated output voltage. The programming current from terminal 3 is factory set to 1.000 mA. If multiple switches or relays are used to program different levels, make-before-break contacts are recommended. See Figure 3-5 for strapping requirements.

(2) External Voltage Programming. The voltage coefficient for external voltage programming is 5 volts - 100% of rated output voltage. To program voltage slightly above the rated output will not damage the unit, but degraded performance may result. See Figure 3-6 for strapping requirements.

d. Remote Sensing.<sup>1</sup> In applications where the load is located some distance from the power supply or the voltage drop of the power output leads significantly interferes with load regulation, remote voltage sensing may be used. When remote sensing is used, voltage is regulated at the load versus the power supply output terminals. To connect the power supply for remote voltage sensing (see Figure 3-7 for strapping requirements):

#### CAUTION

If power supply is operated with load power lines disconnected and sensing line connected, internal power supply damage may occur.  
(Output current then flows through sensing terminals.)

(1) Remote jumper between the positive sense terminal (TB1-2) and the positive output monitor terminal (TB1-1).

(2) Remove jumper between the negative sense terminal (TB1-6) and the negative output monitor terminal TB1-7.

(3) Connect sensing leads from the load positive to TB1-2 and the load negative to TB1-6. A shielded, twisted pair is recommended to avoid potential noise interference.

---

<sup>1</sup>Except in models in excess of 60 VDC output.

e. Remote Output On/Off Control. Remote on/off control may be accomplished by contact closure or by an external AC/DC voltage source.

(1) Remote on/off by contact closure. See Figure 3-8 for strapping requirements. Output is on when contacts are closed.

(2) Remote on/off control may be accomplished by an external AC voltage of 12 to 240 VAC or an external DC voltage of 6 to 120 VDC. See Figure 3-9 for strapping requirements.

#### NOTE

The following modes of operation are used for applications requiring greater output current or voltage than is available from a single power supply. To meet the requirements for greater output, two or more supplies may be connected in parallel or series.

f. Auto-Parallel Operation. In the auto-parallel mode of operation, a master/slave configuration is established.

#### CAUTION

When using two or more supplies in parallel, damage may occur to slave(s) crowbar circuits if slave overvoltage level set is not higher than the master overvoltage level set. To prevent damage, set all slave units overvoltage-set potentiometers fully clockwise and the master unit to the desired trip level. If overvoltage protection is not desired, set to trip at maximum rated voltage (less than fully clockwise).

To setup the auto-parallel mode of operation, connect all outputs in parallel to load. Connect jumper from master TB1-12 to slave TB1-9 and TB1-10. Remove jumper between slave TB1-8 and TB1-9. Rotate slave voltage control potentiometers to maximum and adjust current control potentiometers for balanced output currents during operation. Once adjusted, output currents will track automatically. If tracking is not closed, perform the calibration procedures listed in Chapter 5. See Figure 3-10 for strapping requirements.

g. Auto-Series Operation.<sup>2</sup> In the auto-series mode of operation, a master/slave configuration is established. With two or more supplies connected in series, one is established a master and the remaining units as slaves. The master supply must always be the most positive unit. When operating in the auto-series mode, voltage control potentiometer settings determine the percentage of total load voltage contribution by slave units. current control potentiometers of the slave units are active and should be set to maximum clockwise position. See Figures 3-11 and 3-12 for the strapping requirements.

h. Auto-Tracking Operation.<sup>3</sup> In the auto-tracking mode of operation, a master/slave configuration is established. In this configuration, two or more supplies may be connected with common negative outputs. The slave(s) output voltage is a percentage of the master as controlled by the slave(s) voltage control potentiometers. Individual current controls on both master and slave(s) remain active. See Figures 3-13 and 3-14 for strapping requirements.

---

<sup>2</sup>For models in excess of 60 volts, see Figure 3-12.

<sup>3</sup>For models in excess of 60 volts, see Figure 3-14.

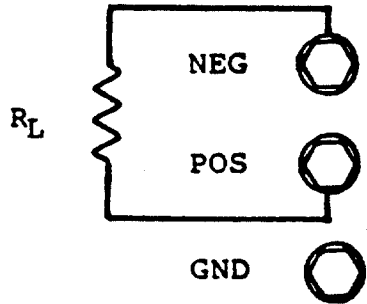
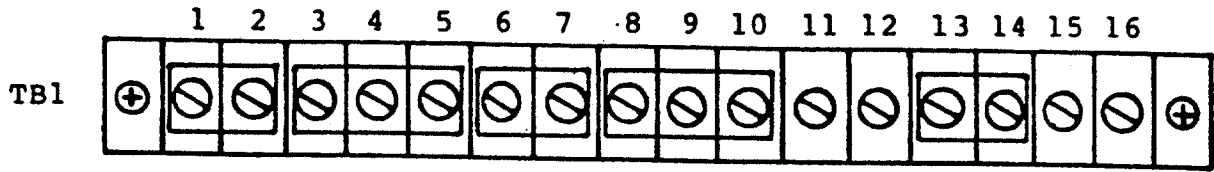
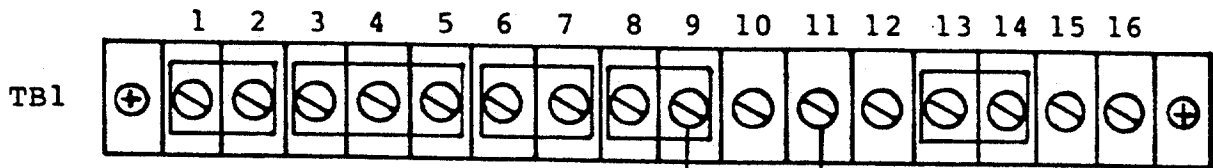

Figure 3-2. Normal Strapping Pattern



0-100  $\Omega$   
PROGRAMMING  
RESISTOR

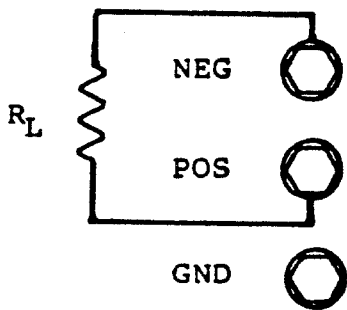

Figure 3-3. Remote Resistance Programming of Output Current

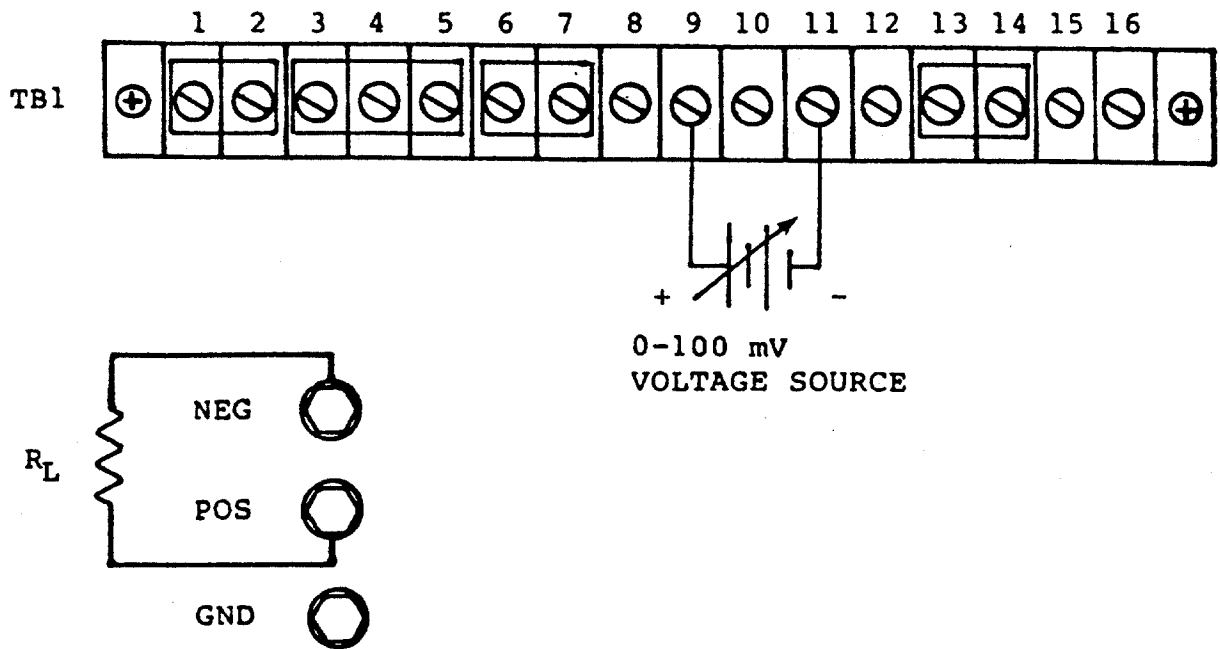

Figure 3-4. Remote Voltage Programming of Output Current

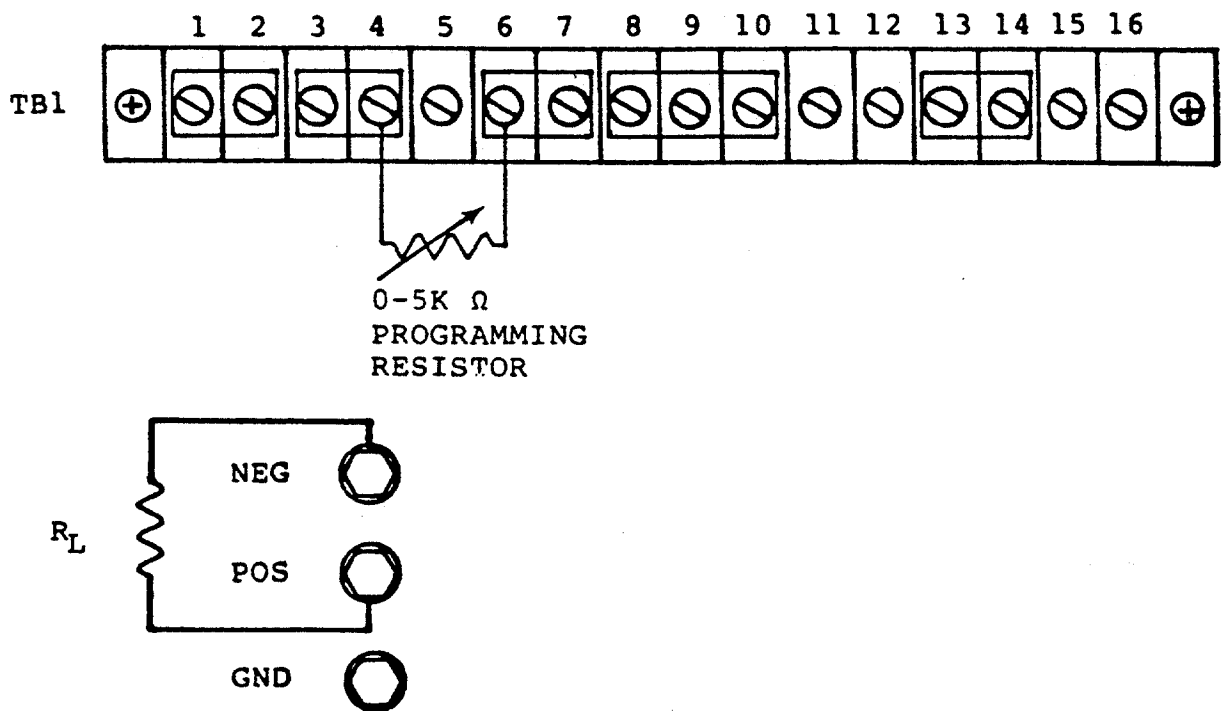

Figure 3-5. Remote Resistance Programming of Output Voltage

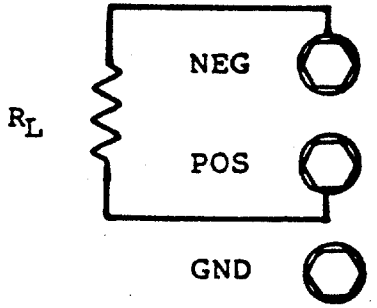
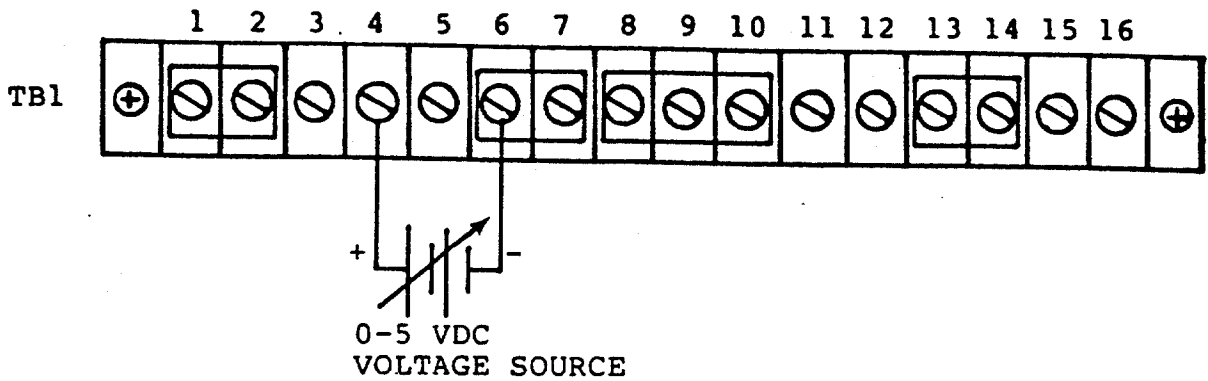

Figure 3-6. Remote Voltage Programming of Output Voltage

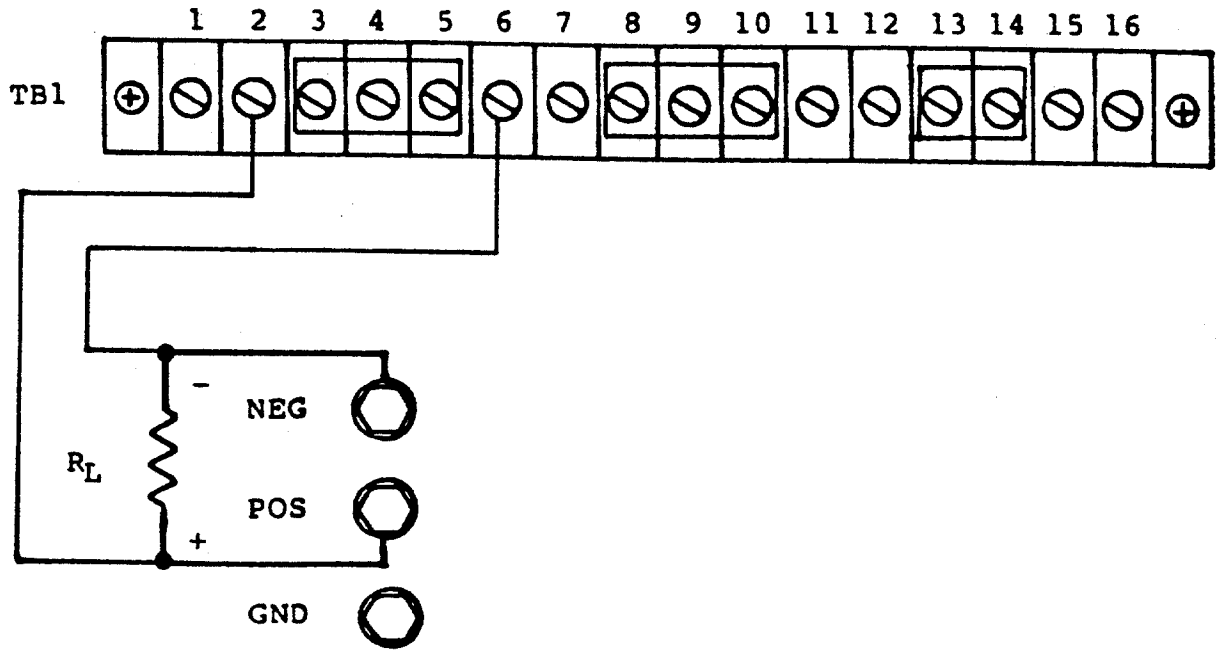

Figure 3-7. Remote Sensing Operation

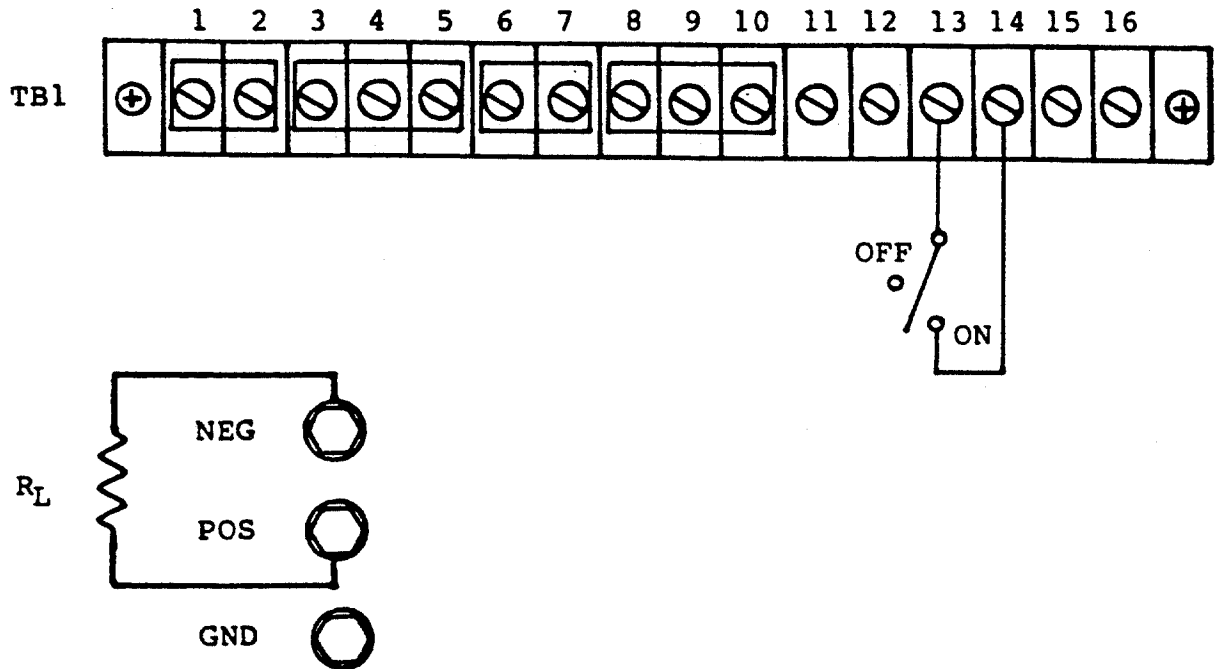

Figure 3-8. Remote On/Off Control by Contact Closure

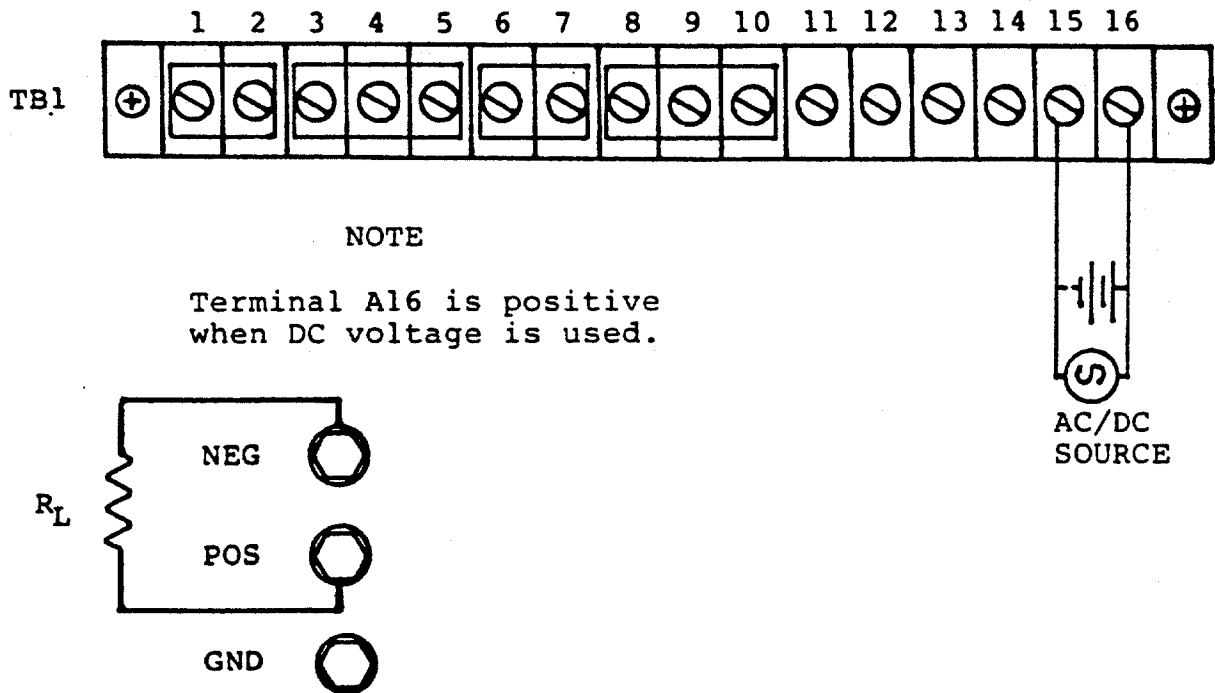

Figure 3-9. Remote On/Off Operation Using AC/DC Voltage Source

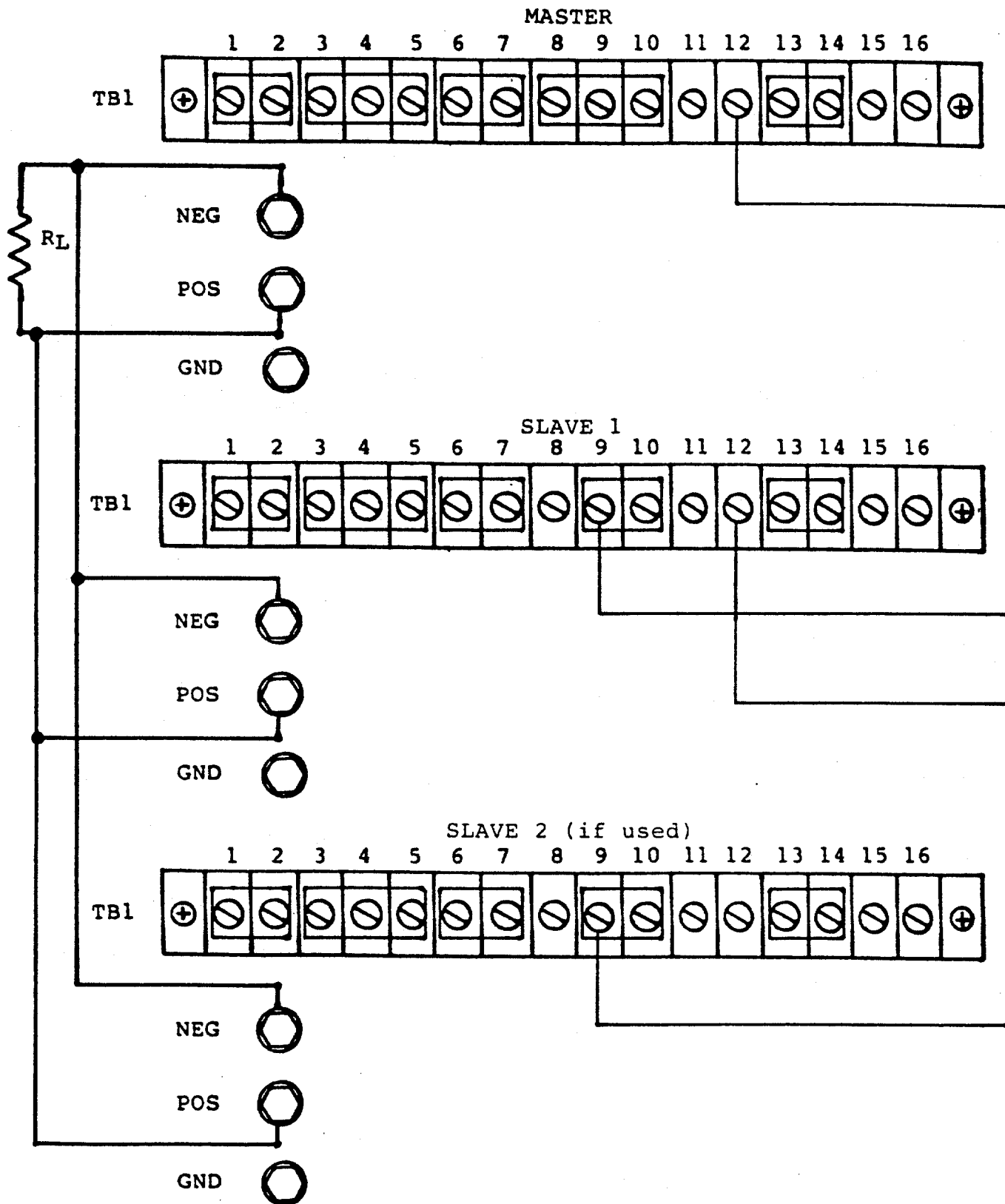
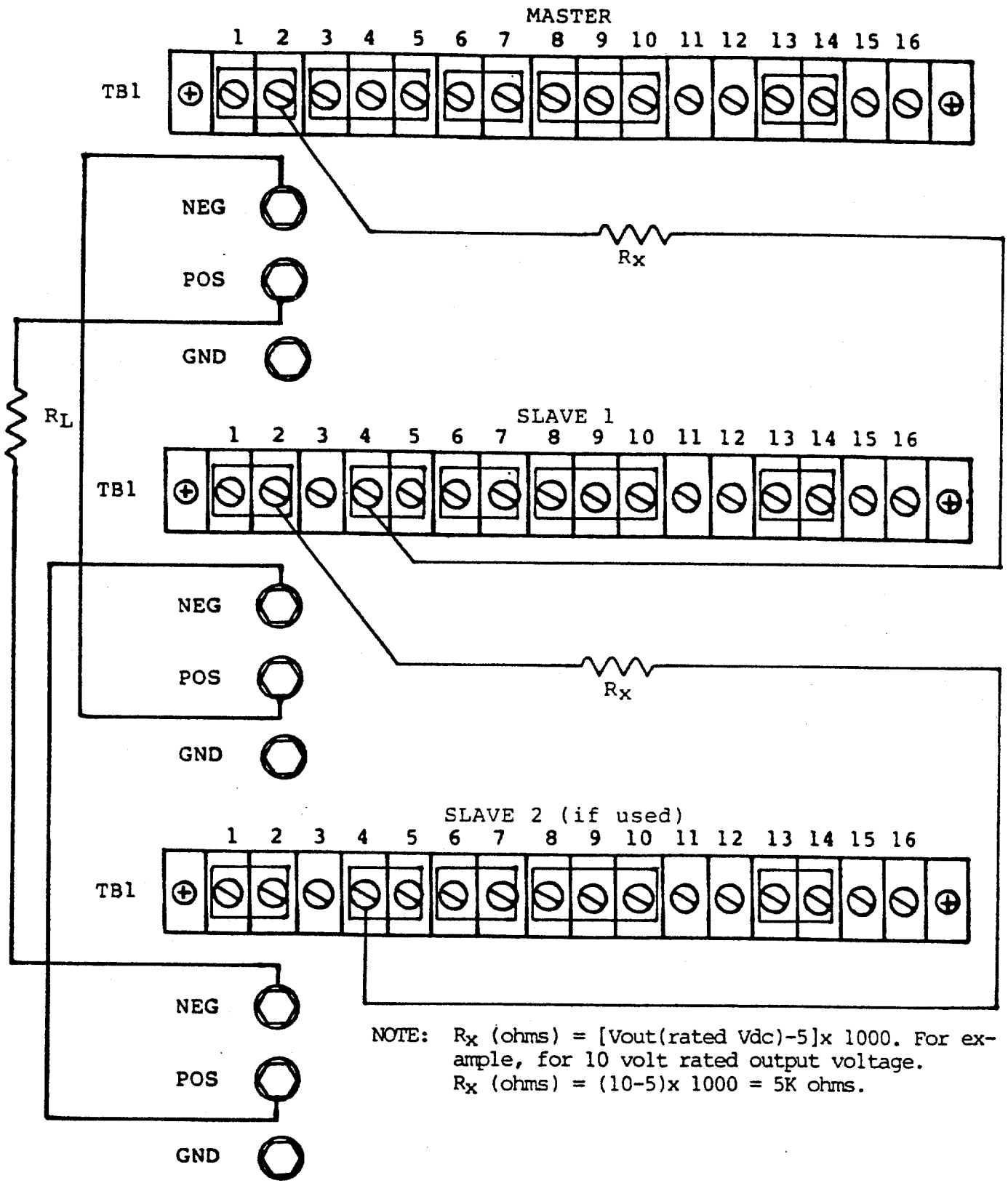

Figure 3-10. Auto-Parallel Operation



NOTE:  $R_x$  (ohms) =  $[V_{out}(\text{rated Vdc}) - 5] \times 1000$ . For example, for 10 volt rated output voltage.  
 $R_x$  (ohms) =  $(10 - 5) \times 1000 = 5K$  ohms.

Figure 3-11. Auto-Series Operation

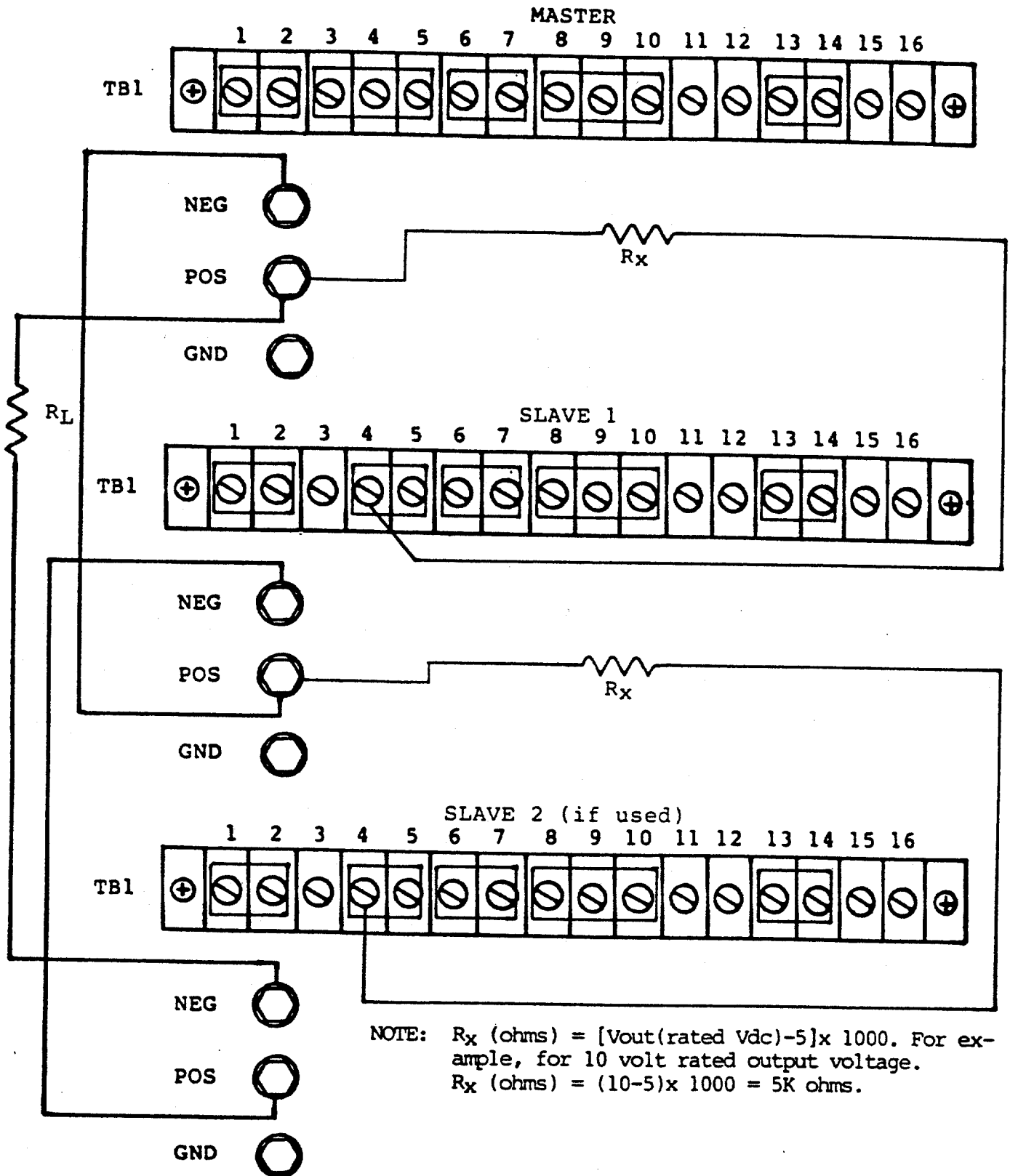

Figure 3-12. Auto-Series Operation

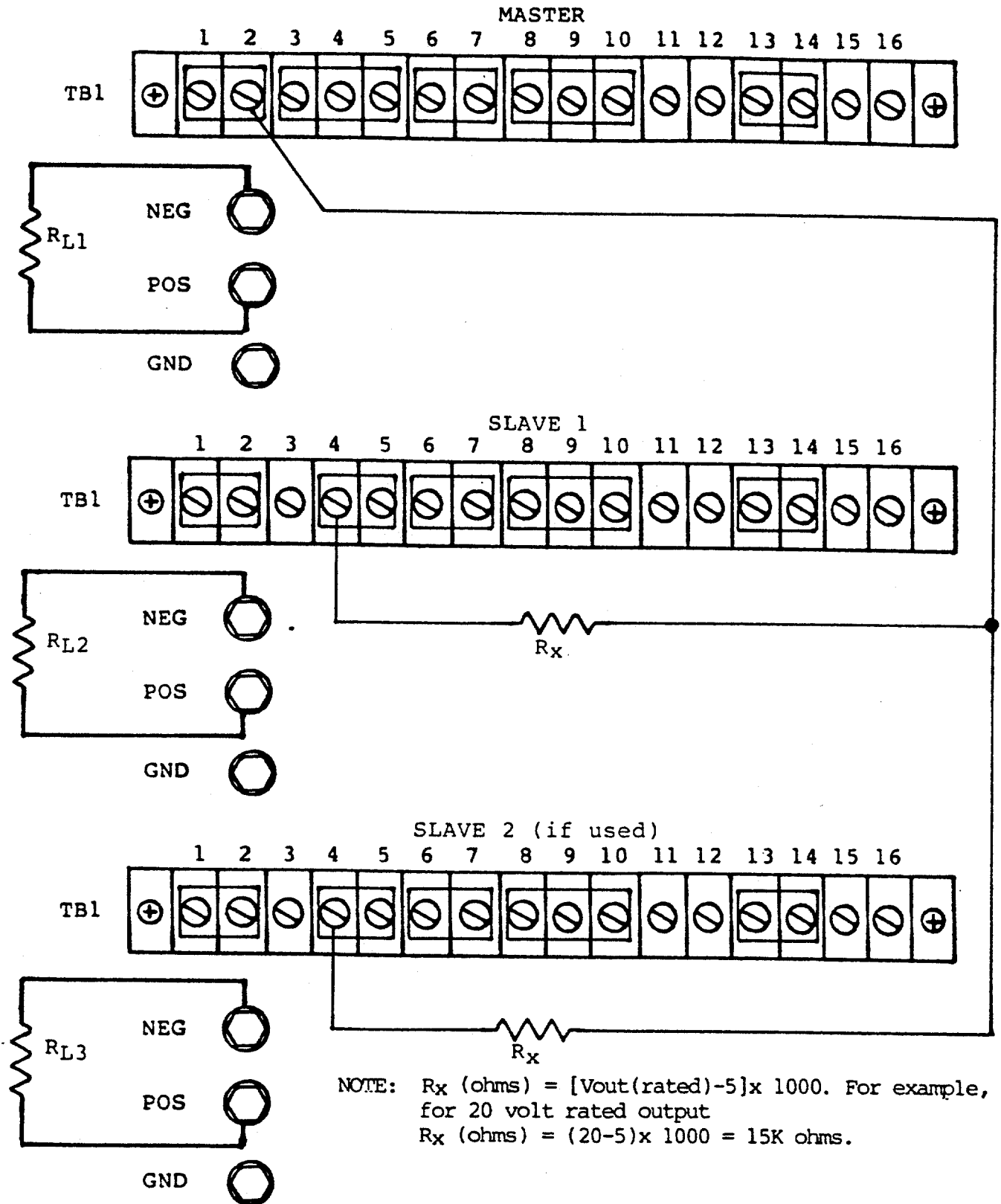

Figure 3-13. Auto-Tracking Operation

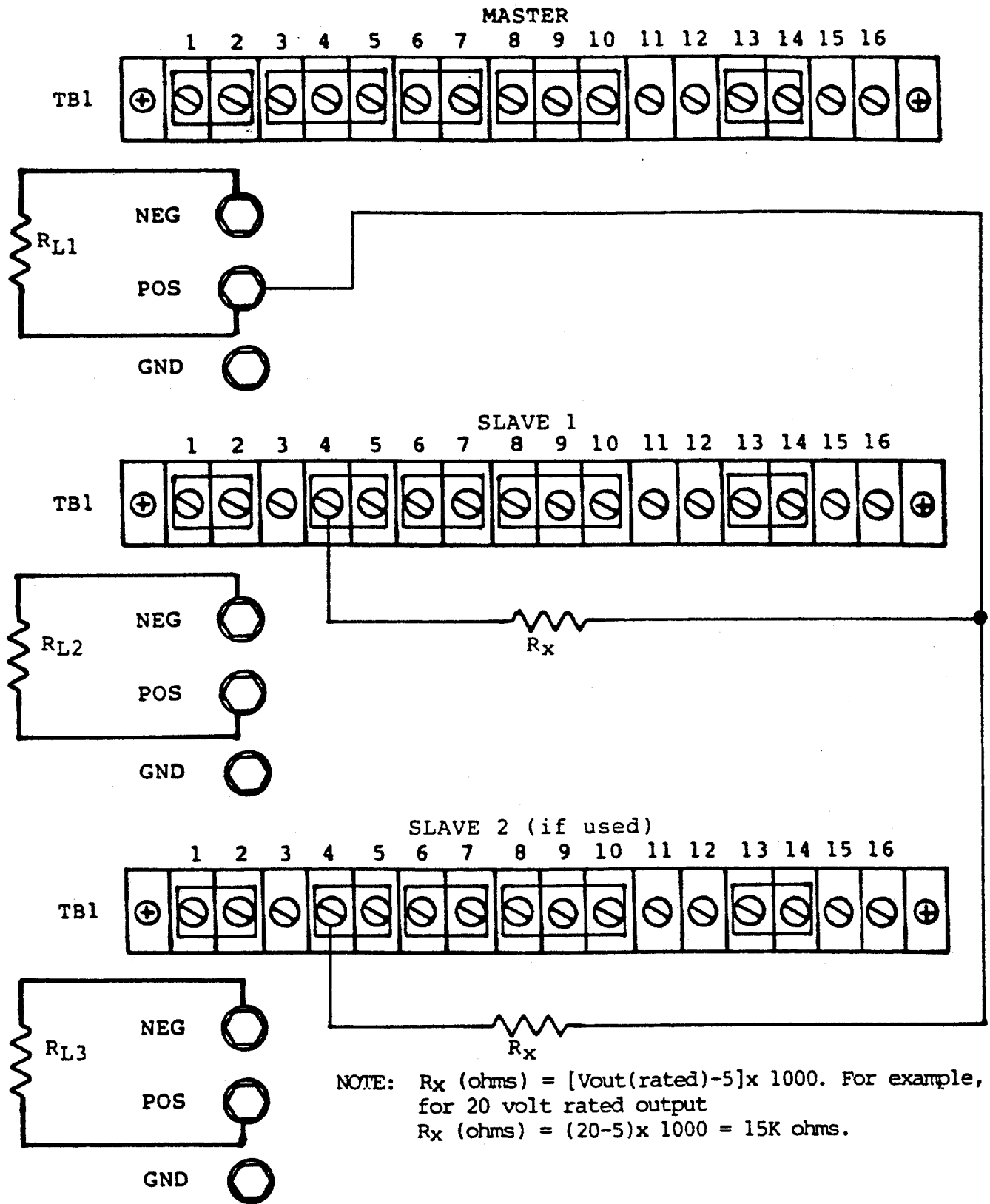

Figure 3-14. Auto-Tracking Operation

## CHAPTER 4

### PRINCIPLE OF OPERATION

#### 4-1. INTRODUCTION

This chapter provides a description of the Series 3400 power supply.<sup>1</sup> Reference schematics 3400-91, 10-010-073-90 (A1), 10-010-074-90 (A2) and 10-010-086-90 (A3).

#### 4-2 GENERAL DESCRIPTION

The Series 3400 power supply is an on-line switching supply operating at approximately 20 kHz. Regulation is attained by a pulse-width modulator. There are two major subassemblies in each power supply.

a. Converter Assembly (A1). The converter assembly A1 is a full-bridge converter for 2 kW units. Assembly A1 converts the unregulated input DC voltage pulse-width modulated 20 kHz AC to drive the power transformer T2.

b. Control Assembly (A2). The control assembly is the central control for the power supply including local/remote controls, indicator, monitors, meters sensing and protection circuits.

c. Display Assembly (A3). The display assembly primarily contains the front panel digital meters, indicators and overvoltage adjustment potentiometer.

d. Top Assembly. The top assembly includes the input power distribution section, the output rectifier filter section and all the front panel meters and controls.

#### 4-3. DETAILED CIRCUIT DESCRIPTION

a. Top Assembly (reference schematic 3400-91).

(1) Input Power Distribution Section. This section includes input EMI filter, circuit breaker, the blower to provide cooling for the power supply, and the bias transformer. Power input from the rear panel is routed through the EMI filter FL1, series circuit breaker CB1 and the primary of bias transformer T1. It is also routed to BR2 on the converter assembly A1. The secondary of T1 is also routed to assembly A1 to provide an input to the  $\pm 12$  VDC bias regulators and the +15 VDC blower regulator.

---

<sup>1</sup>The following drawings document the standard Series 3400 product. For special applications or high voltage units, reference the List of Materials for applicable drawings.

(2) The Output Rectifier Filter Assembly. The AC output in the converter assembly A1 is routed to the primary of T2. The secondary of T2 is rectified by CR1 and CR2, filtered by L1, C3 and C4, and routed to the output busbars. Current sensing is accomplished by R1 and is routed to the control assembly for current control. R5 is a bleed resistor. The output voltage at the output busbars is sampled and routed to control assembly to provide voltage regulation, when using local voltage sensing.

(3) The Front Panel Controls and Meters. The front panel controls and meters are defined on schematic 3400-90. The meters are adjustable for full-scale calibration. See paragraph 5-5h for calibration procedures.

b. Converter Assembly A1 (reference schematic 10-010-073-90). The primary purpose of the converter assembly is to convert the input DC unregulated line to a pulse-width modulated regulated AC primary drive to power transformer T2.

The converter assembly contains the  $\pm 12$  V bias regulators, the +15 V blower regulator, the bias enable circuit, the thermal detector circuit, the slow start for the pulse-width modulator, the pulse-width limiter circuit, the pulse-width modulator, the basedrive amplifiers, base drive circuits and power switches U10, U11, U12 and U13.

(1)  $\pm 12$  V Bias Regulators. The AC input bias is routed through J1, pins 3 and 4, to BR1. The output of BR1 is a nominal  $\pm 17$  V and is filtered by C1 and C2, respectively, then routed to U1 and U2. U1 provides a +12 V regulated output bias to drive all internal power supply housekeeping functions. U2 provides a -12 V internal bias for the same purpose.

(2) +15 V blower regulator. The nominal 17 V positive output of BR1 is routed to the input of U6 which is a 3 terminal 15 V regulator. Its only purpose is to provide a 15 VDC to the blower for the power supply cooling.

(3) Bias Enable Circuit. The bias enable circuit prevents power supply operation should bias voltages become marginal. This would occur during a brown out condition or because of a malfunction of the bias supply.

The U3B and the voltage divider R13 and R14 comprise a voltage comparator circuit which uses the pulse-width modulators 5 V reference as a reference output to the inverting input pin 4. When the unregulated bias voltage at BR1 positive output is below 15 V, the output of U3B, pin 2, is low, thereby inhibiting the pulse-width modulator slow start circuit. This prevents the pulse-width modulator from switching. The output of the bias enable circuit U3B is ORed with the thermal detector circuit U3A.

(4) Thermal Detector Circuit. The purpose of the thermal detector circuit is to provide protection for the bridge converter in the case that the cooling is inadequate or the power supply is subjected to temperatures above the normal specified operating range.

The reference input for U2A, pin 7, is provided by the 5 V reference from U4 through R17, R18 voltage divider. The input temperature is sensed by U5 which provides a linear ramp of 10 mV per degree C at the input (pin 6). When the temperature of the power supply exceeds a safe operating level, pin 6 exceeds the reference of pin 7, thereby activating U3A and shutting down the pulse-width modulator via the slow start circuit U3C and U3D.

(5) Slow Start Circuit. The slow start circuit consists of U3C which is used as a comparator and U3D which is a voltage follower. The input to the detector portion U3C can be provided by either bias enable circuit, thermal detector circuit or the on/off control circuit on the logic board. When pin 11 is allowed to go high above pin 10, pin 13 is allowed to rise, charging C12 through R22. U3D is a simple voltage follower providing this rising voltage at the compensation pin of U4. This allows the pulse-width to start from 0 pulse-width and slowly increase to the normal operating pulse-width.

(6) Pulse-width Limiter Circuit. The pulse-width limiter circuit consists of Q9 and a resistor divider of R28 and R29. The divider R28 and R29 provide approximately 2.8 volts at the base of Q9, which allows the emitter to set at approximately 3.4 volts. The emitter of Q9 is tied directly to the compensation point of U4 limiting the positive excursion of pin 9. This also limits the pulse-width output provided by U4.

(7) Pulse-Width Modulator. The pulse-width modulator U4 is the central control for pulse-width modulation within the power supply. It is controlled by all of the logic functions as well as the regulation loops.

The paragraphs above describe the inputs to the pulse-width modulator for shutdown and slow start, pulse-width limiting on/off control, thermal detector, and bias enable. The other input is in the error amplifier, pins 1 and 2, which provides linear voltage or current regulation inputs. The reference input to U4, pin 2, is provided from the 5 volt reference at pin 16 through divider R28 and R29. The error signal input coming from the logic and control board is routed through J2, pin 3, to divider R26 and R27. This junction of the divider is routed through R25 to U4, pin 1. R24 and C15 provide a compensation network for stability. The output pulse-width modulation information is routed through pins 11, 12, 13, 14 to the cognizant basedrive amplifiers.

(8) Basedrive Amplifiers. The purpose of the basedrive amplifiers is to amplify the pulse-width modulation signal from

U4 and condition it to drive the basedrive transformers T1 and T2. Both basedrive amplifiers are identical, so only one will be described to provide theory of operation.

The pulse-width modulator output of U4 consists of a transistor driver with an uncommitted collector and emitter on pins 11 and 12. Q3 and Q4 further amplify the output. CR5 and CR6 comprise the Baker Clamp for Q3 which reduces storage time and speeds up turn off. C10 assures adequate negative bias during turn off of the power transistors. C10 is charged by pull-down transistor Q8 through R11 and discharge by pull-up transistor Q4 through the primary of T2.

#### NOTE

T2 is DC coupled to the amplified pulse-width modulator output and swings between +Vcc and -Vcc excluding diode and saturation voltage drops. This assures that during very narrow pulse-widths, power transistors receive adequate negative basedrive.

(9) Basedrive Circuits. Basedrive and snubber circuits are identical for the four transistor switches so only one will be described, Q10. Basedrive power is provided by the basedrive amplifier to basedrive transformer T1. T1 secondary provides +5 V basedrive at pin 5 during the Q10 switch-on period. This +5 V is routed through R32 and CR12 to the base of Q10. C19 provides a high peak current during Q10 turn on which decreases the transistor switch time and minimizes transistor power losses during the turn-on cycle. The -5 V from T1 is coupled through CR9 to the base of Q10 to provide negative bias during the Q10 turn-off time. Diodes CR11 and CR12 comprise a Baker clamp to reduce switch transistor Q10 storage time. C21 and series resistor R40 through R44 provide snubbing for switch transistor Q10 which reduces the transistor switching losses during the turn-off cycle.

(10) Converter Switch Transistors. The Series 3400 two kilowatt power supplies utilize a full-bridge converter consisting of switch transistors Q10-Q13 with associated basedrive and snubber circuits.

The one kilowatt versions utilize a half-bridge configuration consisting of switch transistors Q12 and Q13 with associated basedrive and snubber circuits. Q10, Q11 and associated basedrive and snubber circuits are removed. C26 is replaced by a pair of capacitors, C26A and C26B, which is returned to the 300 V and 300 V return, respectively. The half-bridge operates similar to the full-bridge except that the output voltage to the power transformer is reduced to half.

c. Control Assembly A2 (Reference schematic 10-010-074-00). The control assembly is the central control of the power supply. The control circuit contains the voltage and current reference circuits, the voltage and current control circuits, the current limit circuits, the current monitor or parallel tracking amplifier circuit, the indicator drivers, the remote interface and the remote on/off control.

(1) Voltage Reference Circuit. The voltage reference circuit is an adjustable current source which is factory set for one milliampere. This reference is routed to TB1-3 (Vprog.) for either local or remote voltage control via resistance. The circuit consists of Q1 and associated components and a reference voltage source provided by VR1 and temperature compensation diode CR3.

(2) Current Reference Circuit. The current reference circuit is identical to the voltage reference circuit described above. It consists of Q3 and associated components and is routed to TB1-8 (Iprog.) for local or remote current control via resistance.

(3) Voltage Control. Voltage control and error amplification are provided by U4 and associated components. The (+) non-inverting sensing input is routed from the (+) sensing terminal of TB1 through resistor divider R44, R45, R46. The (-) inverting control input is routed (local or remote operation) from TB2-4 (Vcont) through impedance matching resistor R37. The lead network R39 and C24 provides voltage loop compensation. Error amplifier U4 amplifies any error signal and provides a control signal to the pulse-width modulator through CR9, when operating in the voltage mode. C20 provides voltage loop compensation. R35 is an offset adjustment for zero nulling (see Chapter 5 for calibration procedures).

(4) Current Control. Current control and error amplification are provided by U6 and associated components. Current control (local or remote) is routed from TB2-9 through resistor R50 to the (-) inverting input of error amplifier U6. R49 and C27 provide a lead network for current loop compensation. The (+) non-inverting input is routed from the current shunt R1 of the top assembly through J2-14 and impedance matching resistor R48. Error amplifier U6 compares the inputs, amplifies any error signal and provides a control signal to the pulse-width modulator through CR7, when operating in the current mode. R33, C19 and C23 provide additional current loop compensation. R38 is an offset adjustment for zero nulling (see Chapter 5) for calibration and adjustment procedures).

(5) Current Limit. The current limit circuit consists of U3 and associated components. The (-) inverting (reference) input is provided by resistor divider R26 and R29 through impedance matching resistor R27. The (+) non-inverting input is provided by the current shunt, R1, of the top assembly and routed

through impedance matching resistor R30. The current limit error amplifier is only activated when power supply output current exceeds rated output by approximately 5 percent. A lead network consisting of R31 and C16 along with compensation capacitor C15 provide stability when operating. The output is routed to the pulse-width modulator through CR6.

(6) Current Monitor/Parallel Tracking Amplifier. The current monitor/parallel tracking amplifier consists of U1 and associated components. The primary purpose of this amplifier is to provide an output of 0 to 1 mA to TB1-12 (I<sub>mon</sub>+) corresponding to 0 to 100 percent of rated output current, when used in a parallel configuration. When not used for parallel operation, TB1-12 provides a 0 to 5 VDC monitor signal corresponding to 0 to 100 percent of rated output current. Both amplifier inputs are provided by current shunt R1 on the top assembly. Gain is controlled by resistors R7 and R9 which are factory selected to provide 0 to 5 VDC for 0 to 100 percent output at U1-6. This 0 to 5 VDC is routed through R43 to provide 0 to 1 mA, when used in the parallel configuration.

(7) Remote On/Off Output Control. Remote on/off control may be accomplished by two methods.

(a) Switch or contact Closure. A switch, set of relay contacts, or a semiconductor switch, may be used to provide contact between TB1-13(-) and TB1-14(+). When using a semiconductor switch, it must be capable of sinking approximately 1 milliampere of current from TB1-14(+) to TB1-13(-) return.

(b) AC/DC Voltage Source. An isolated (floating) input at TB1-15 and TB1-16 is available for either 12 to 240 VAC or 6 to 120 VDC source on/off control. When DC voltage is used for control the (+) positive input is TB1-16 with reference to TB1-15 return.

Both methods of using remote on/off output control require that the jumper between TB1-13 and TB1-14 be removed.

An AC or (+)DC voltage input to TB1-16 provides current flow through CR13, R41, R47 and U5 opto-coupler back to TB1-15 return. U5 transistor output is activated, thereby removing base drive from Q4 through R34 switching off Q4. When Q4 is off, the pulse-width modulator U4 is allowed to operate. When a switch, contact closure or semiconductor switch is used between TB1-14(+) and TB1-13(-), the input is in parallel with U5 and operates in a similar manner as described above.

(8) Voltage/Current Mode Indicators. The indicators LED 1 (voltage) and LED 2 (current) are driven by U2-A and U2-B, respectively, through R20 and R21. U2-A and U2-B inputs are tied together with inverted inputs providing one output high at all times.

When the power supply is operating in the voltage control mode, the output from U4 is more positive than from U3 or U6. The output is coupled through CR4 to U2-4(+) input and U2-B(-) input, thus causing U2-A output to be high. This output drives the voltage mode indicator.

When the power supply is operating in the current control mode or current limit mode, the output of U3 (current limit) or U6 (current control) will be more positive than U4 (voltage control). The output is coupled through CR5 (U3) or CR9 (U6) to the (+) input of U2-B and the (-) input of U2-A. This drives the output of U2-B high for the current mode indicator.

(9) Remote Interface. The remote interface is the barrier strip TB1 and appropriate jumpers to permit user selection of local/remote voltage or current controls and local/remote voltage sensing. The barrier strip is mounted directly on the control board, and is accessible at the rear panel. See Chapter 3 of this manual for local/remote control and sensing connections.

d. Display Assembly A3 (Reference schematic 10-010-086-90). The primary purpose of the display assembly is to provide voltage and current meter displays at the front panel. Bias power for the display assembly is provided by the control assembly A2. The  $\pm 12$  V inputs are regulated by U1(+) and U2(-) to provide  $\pm 5$  V power to the A/D converters U3 and U4.

The A/D converters with associated components provide all necessary functions to convert analog input signals to digital driver outputs for the 3-1/2" displays LCD1 and LCD2. Analog inputs are provided by the control assembly A2.

The A/D converters U3 and U4 zero automatically. Full-scale calibration is provided by R8 for the ammeter and R11 for the voltmeter. Fixed decimal point location for the LCD displays is factory set via a solder bridge connection.

Other functions provided are simply a convenient means of mounting for front panel access or viewing. These functions include the overvoltage adjustment potentiometer R1, the overvoltage indicator LED1, the current mode indicator LED2 and the voltage mode indicator LED3.

## CHAPTER 5

### MAINTENANCE AND CALIBRATION

#### 5-1. INTRODUCTION

This chapter contains preventive and corrective maintenance information for the Series 3400. To isolate defective components, use standard troubleshooting procedures in conjunction with the principles of operation in Chapter 4, the list of materials information in Chapter 6 and the illustrations in Chapter 7.

#### 5-2. EQUIPMENT REQUIRED

Table 5-1 lists the test equipment required to perform maintenance on the Series 3400. The recommended model or an equivalent may be used.

#### 5-3. PREVENTIVE MAINTENANCE

Preventive maintenance for the Series 3400 consists of scheduled inspection and cleaning.

a. Schedule. Table 5-2 lists the preventive maintenance routines and the recommended performance intervals.

b. Inspection. Table 5-3 lists the visual inspection checks to be performed. It also indicates the corrective action to be taken.

c. Cleaning. Cleaning requirements are based on the need established during inspection. If cleaning is required, follow the instructions listed in the corrective action column of Table 5-3.

#### 5-4. REPAIR

Repair of the Series 3400 is performed by removing and replacing failed parts and components. Information required to order replacements is contained in Chapter 6, List of Materials.

Table 5-1. Test Equipment Required

COMMON NAME	REQUIRED CAPABILITIES	RECOMMENDED MODEL
Digital Multimeters	AC and DC Ranges	Hewlett-Packard Model 3468A
Oscilloscope	Signal and Waveform Measurement	Tektronix 2215
Resistive Load	For Full Rated Output Voltage and Current of P.S. Model Type	

Table 5-2. Preventive Maintenance Schedule

PREVENTIVE MAINTENANCE ROUTINE	RECOMMENDED PERFORMANCE INTERVAL
Inspection	Annual
Cleaning	As Required

Table 5-3. Inspection and Corrective Action

ITEM	INSPECT FOR	CORRECTIVE ACTION
Connector plugs and jacks	Looseness, bent or corroded contacts, damage or improper seating in mating connector	Clean contacts with solvent moistened cloth, soft bristle brush, small vacuum or low compressed air.  Replace connectors damaged, deeply corroded, or improperly seated in mating connector.
Chassis, blower & extruded heatsinks	Dirt and Corrosion	Clean with cloth moistened with soapy water.
Electrical wiring	Broken, burned or pinched wire; frayed, worn or missing insulation	Repair or replace defective wires.
Soldering connections	Corrosion, loose, cracked, or dirty connections	Clean and resolder connections.
Dirt and moisture buildup	Short circuits, arcing, corrosion, overheating	Clean as required.
Front panel controls and meters	Dirt and corrosion	Clean with cloth moistened with soapy water.  Use a Kimwipe tissue and GTC glass cleaning compound to clean the meter faces.

## 5-5. CALIBRATION AND ADJUSTMENTS

To perform the following calibration and adjustment procedures, the cover must be removed from the power supply. Because removal of the cover allows access to potentially hazardous power voltages (up to 253 VAC) and because of the importance of accurate readings to performance, only technically trained personnel should perform calibration procedures.

### WARNING

Hazardous voltages (up to 253 VAC) are present during equipment operations. Press switch to OFF position and disconnect power cord from power source. Allow a minimum of 3 minutes for discharge of storage capacitance before removing the cover or performing any maintenance function.

Reference assembly 10-010-074-XX while performing calibration procedures.

a. Voltage Reference. The voltage reference is provided by an adjustable current regulator Q1. To calibrate for the 1 mA programming coefficient (constant voltage) the following sequence is recommended.

- (1) Remove all jumpers and external connections to TB1-3.
- (2) Set current control potentiometer on front panel fully counterclockwise.
- (3) Connect a precision digital multimeter (DMM) to TB1-3(+) with reference to TB1-7(-). Set DMM to DC milliamps and 2 milliamps range.
- (4) Apply power to power supply.
- (5) Adjust R4 for 1.000 milliamps on DMM.
- (6) Remove power from power supply.
- (7) Reconnect all jumpers/connections to TB1-3 as required for local or remote voltage control.

b. Current Reference. The current reference is a precision current source consisting of Q3 and associated resistors. Calibration is accomplished through adjustment of R15. The following sequence is recommended.

- (1) Remove all jumpers and external connections to TB1-8.

- (2) Set voltage control potentiometer on front panel fully clockwise.
- (3) Connect a precision DMM to TB1-8(+) with reference to TB1-11(-). Set DMM to DC milliamps and 2 milliamp range.
- (4) Apply power to power supply.
- (5) Adjust R15 for 1.000 milliamps on DMM.
- (6) Remove power from power supply.
- (7) Remove DMM and reconnect jumpers/connections for TB1-8 as required for local or remote current control.

c. Voltage Zero Calibration. The voltage control circuit (U4) zero is adjusted by R35. The following sequence is recommended.

- (1) Connect jumper (short circuit) between RB1-4 and TB1-6.
- (2) Connect resistive load and DMM across output terminals of power supply. Set DMM to read DC volts and approximately 200 millivolt range.
- (3) Set current control potentiometer fully clockwise.
- (4) Apply power to power supply.
- (5) Adjust R35 until the power supply output voltage starts to increase in the normal polarity. Reverse adjustment direction of R35 until output voltage decreases to zero reading on the DMM. Do not continue adjustment once the output reads zero millivolts.
- (6) Remove power from power supply.
- (7) Remove resistive load and DMM from power supply output terminals.
- (8) Remove jumper from TB1-4 and TB1-6.

d. Current Zero Calibration. The current control circuit (U6) zero is adjusted with R38. The following sequence is recommended.

- (1) Connect a jumper (short circuit) between TB1-9 and TB1-11.
- (2) Connect a resistive load and DMM across the output terminals of the power supply. Set DMM to read DC volts and approximately 200 millivolt range.

- (3) Set voltage control potentiometer on front panel fully clockwise.
- (4) Apply power to power supply.
- (5) Adjust R38 until the power supply output voltage starts to increase in the normal polarity. Reverse adjustment direction or R38 until output voltage decreases to zero reading on the DMM. Do not continue adjustment when the output reads zero volts.
- (6) Remove power from power supply.
- (7) Remove resistive load and DMM from power supply output terminals.
- (8) Remove jumper between TB1-9 and TB1-11.

e. Current monitor/Parallel Tracking Amplifier Zero Calibration. The current monitor/parallel tracking amplifier zero is adjusted with R3. The following sequence is recommended.

- (1) Connect a jumper (short circuit) between TB1-9 and TB1-11.
- (2) Connect a resistive load across output terminals.
- (3) Connect a DMM between TB1-12(+) and TB1-13(-). Set DMM to DC volts on 0.2 volt scale.
- (4) Set front panel voltage and current control potentiometer fully counterclockwise.
- (5) Apply power to power supply.
- (6) Adjust R3 to 0.00 volts on DMM.
- (7) Remove power from power supply.
- (8) Remove jumper between TB1-9 and TB1-11.
- (9) Remove resistive load from power supply output terminals.

f. Voltage Full-Scale Calibration. Full-scale voltage calibration is adjusted with R46. The following sequence is recommended.

- (1) Connect a resistive load across output terminals.
- (2) Connect a DMM between TB1-2 and TB1-6. Set DMM to DC volts and scale to read maximum rated power supply voltage.

- (3) Connect a second DMM between TB1-4(+) and TB1-7(-). Set DMM to DC volts and scale to read 5.00 volts.
- (4) Rotate current control to maximum clockwise.
- (5) Apply power to power supply.
- (6) Rotate voltage control for 5.00 volt reading on DMM attached to TB1-4 and TB1-7.
- (7) Adjust R46 until output voltage reading is 100 percent of rated output voltage DC between TB1-2 and TB1-7.
- (8) Remove power from power supply.
- (9) Remove DMM's and resistive load from power supply terminals.

g. Display Assembly Calibration. Reference Assembly 10-010-086-XX while performing calibration.

(1) Meter Zero Calibration. The zero set for both voltage and current front panel meters is automatic.

(2) Meter Full-Scale Calibration. The full-scale adjustment for the digital panel meters M1 and M2 is adjusted by R8 and R11, respectively, of the display assembly 10-010-086-00. R8 is for full-scale current meter calibration and R11 is for full-scale voltage meter calibration. Both resistors are accessible from inside the power supply with the cover removed.

To calibrate for full-scale voltage or current, adjust the power supply to maximum rated output voltage (or current) using an external calibrated meter and adjust R2 on the appropriate meter to correspond to the rated output voltage or current.

## CHAPTER 6

### LIST OF MATERIALS

#### 6-1. INTRODUCTION

The repair parts list contains the major parts required to maintain the Series 3400. To ensure accurate procurement of replacement parts, the information contained in the parts list columns must be used effectively. The following paragraph describe the parts list format and include an explanation of the information presented in each of the columns.

The SEQ column contains the sequence number in ascending order. The REFERENCE column contains the reference designations of the electrical components. The DESCRIPTION column contains the standard identifying noun or item name. The ITEM column contains the part number Power Ten has assigned to items both purchased and Power Ten manufactured. The QUANTITY column contains the quantity for a unique configuration which is identified by a dash number.

## CHAPTER 7

### ILLUSTRATIONS

#### 7-1. INTRODUCTION

This chapter contains the appropriate schematic drawings for you model of the Series 3400.

3400(1KW) UNIT SHOWN. SEE PAGE 2 FOR 3450 OR 3400(2KW).

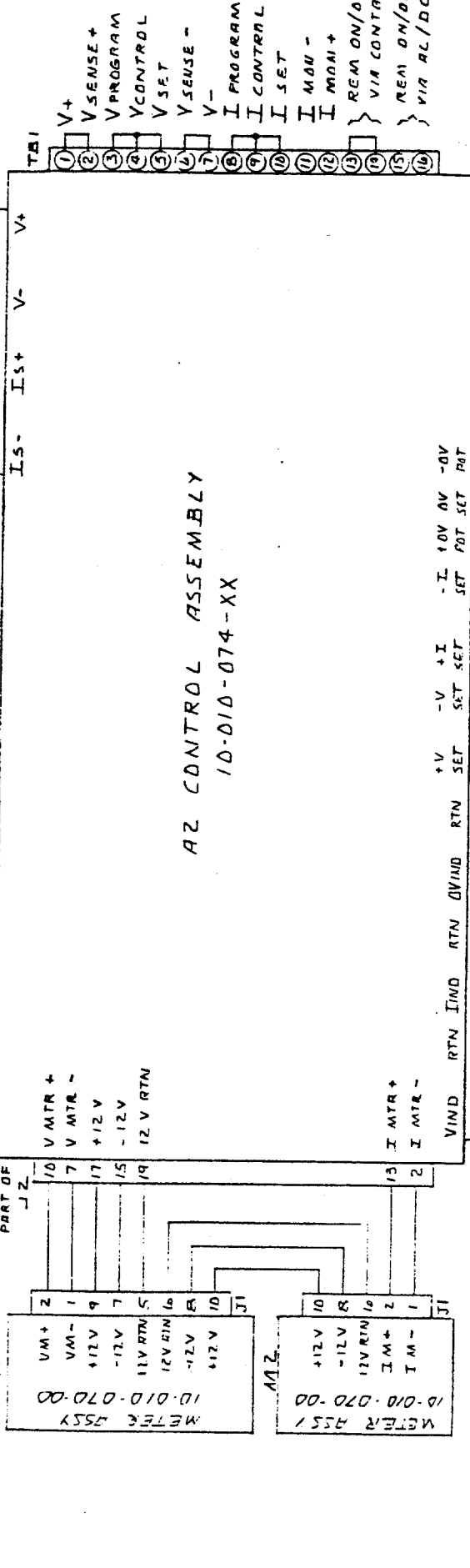
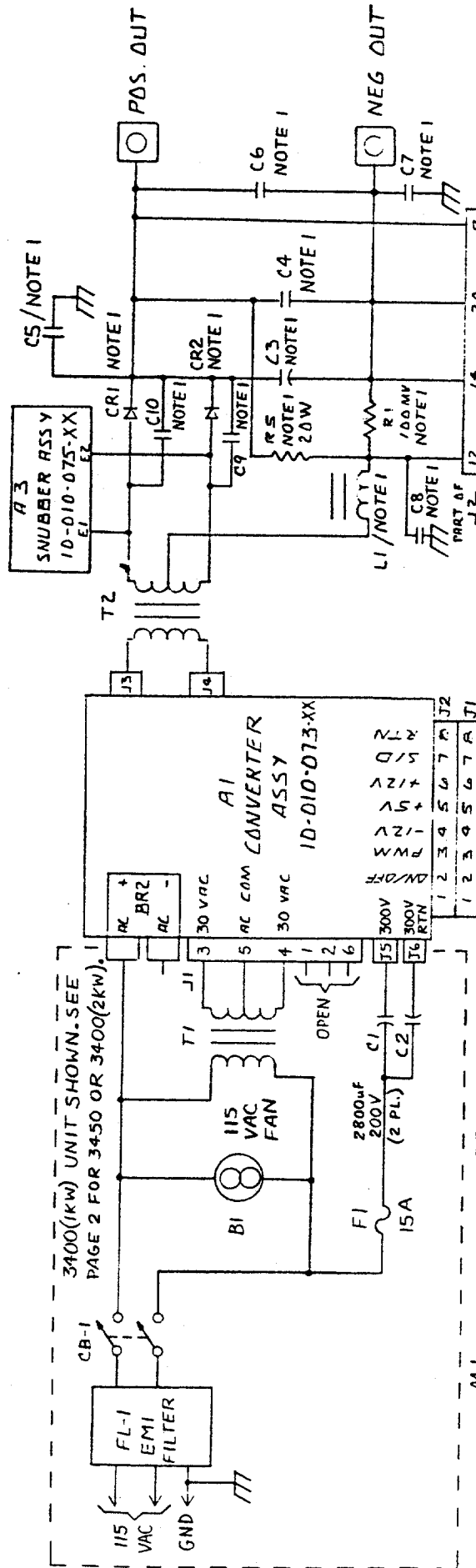

A2 CONTROL ASSEMBLY  
10-D10-074-XX

- 1 V+
- 2 VSENSE+
- 3 VPROGRAM
- 4 VCONTROL
- 5 VSET
- 6 VSENSE-
- 7 V-
- 8 IPROGRAM
- 9 ICONTROL
- 10 ISET
- 11 MDM-
- 12 MDM+
- 13 REM ON/OFF
- 14 VIA CONTACTS
- 15 REM ON/OFF
- 16 VIA RL/DC

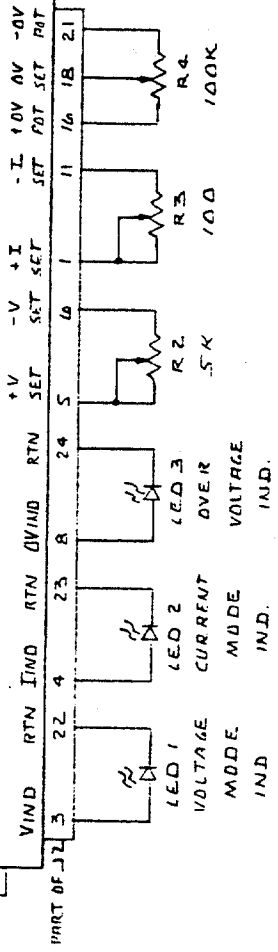

NOTES:  
1. REFER TO L/M.

POWER TEN INC.  
MINNETONKA, MINNESOTA 55345

SCALE: N/A  
DATE: 6-26-85  
APPROVED BY: [Signature]  
DRAWN BY: JB  
REVISED: 2-6-86

SCHEMATIC, 3400 SERIES/3450 SERIES P.S.  
3400-90 / 3450-90  
DRAWING NUMBER  
PAGE 1 OF 2



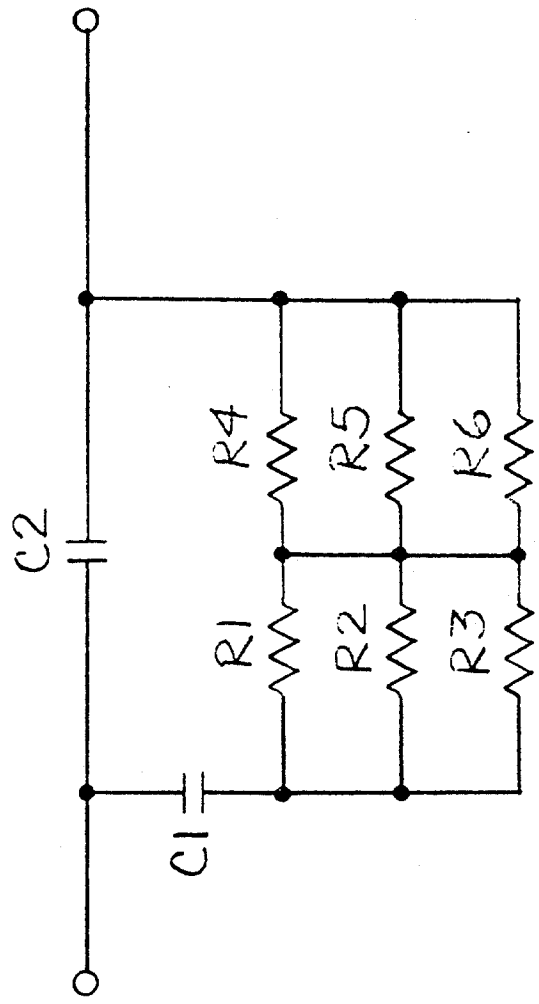

NOTE:  
SEE L/M FOR COMPONENT VALUES.

COPYRIGHT © Power Corp. Inc. 1973

SCALE: NONE	APPROVED BY: <i>P. Simpson</i>	DRAWN BY: CS
DATE: 7-10-85		REVISED
SCHEMATIC, SNUBBER BD, 3400 SERIES		
10-010-075-90		DRAWING NUMBER



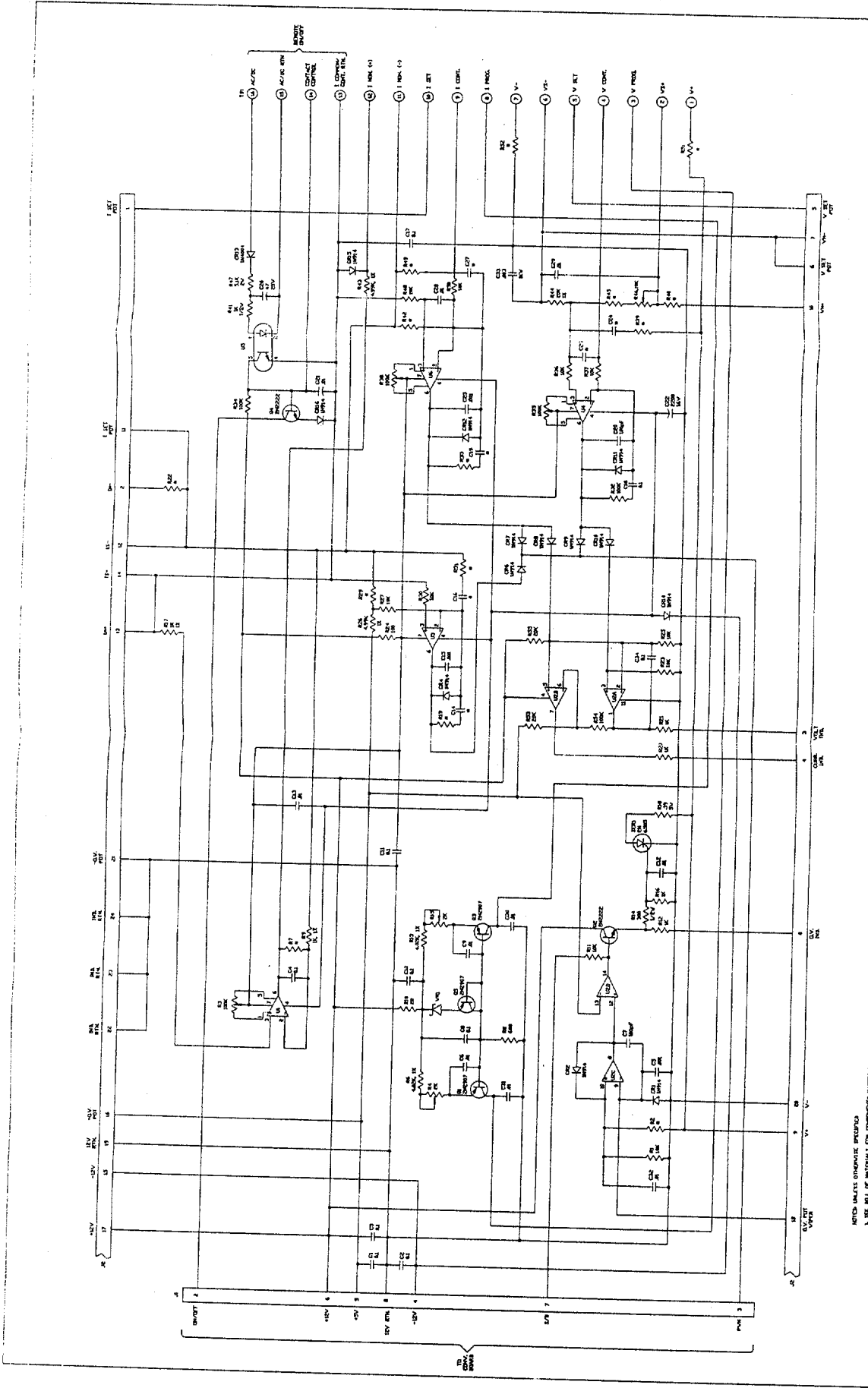

NOTES: UNLESS OTHERWISE SPECIFIED:  
 1. USE BILL OF MATERIALS FOR COMPONENTS MARKED WITH AN asterisk (\*).  
 2. ALL RESISTORS ARE 1/4 WATT, 5% TOLERANCE UNLESS OTHERWISE SPECIFIED IN DASH.  
 3. ALL CAPACITORS ARE 50V UNLESS OTHERWISE SPECIFIED IN DASH.

WIRE BUNDLE LINES  
 100  
 101  
 102  
 103  
 104  
 105  
 106  
 107  
 108  
 109  
 110  
 111  
 112  
 113  
 114  
 115  
 116  
 117  
 118  
 119  
 120  
 121  
 122  
 123  
 124  
 125  
 126  
 127  
 128  
 129  
 130  
 131  
 132  
 133  
 134  
 135  
 136  
 137  
 138  
 139  
 140  
 141  
 142  
 143  
 144  
 145  
 146  
 147  
 148  
 149  
 150  
 151  
 152  
 153  
 154  
 155  
 156  
 157  
 158  
 159  
 160  
 161  
 162  
 163  
 164  
 165  
 166  
 167  
 168  
 169  
 170  
 171  
 172  
 173  
 174  
 175  
 176  
 177  
 178  
 179  
 180  
 181  
 182  
 183  
 184  
 185  
 186  
 187  
 188  
 189  
 190  
 191  
 192  
 193  
 194  
 195  
 196  
 197  
 198  
 199  
 200

WIRE BUNDLE LINES  
 201  
 202  
 203  
 204  
 205  
 206  
 207  
 208  
 209  
 210  
 211  
 212  
 213  
 214  
 215  
 216  
 217  
 218  
 219  
 220  
 221  
 222  
 223  
 224  
 225  
 226  
 227  
 228  
 229  
 230  
 231  
 232  
 233  
 234  
 235  
 236  
 237  
 238  
 239  
 240  
 241  
 242  
 243  
 244  
 245  
 246  
 247  
 248  
 249  
 250

WIRE BUNDLE LINES  
 251  
 252  
 253  
 254  
 255  
 256  
 257  
 258  
 259  
 260  
 261  
 262  
 263  
 264  
 265  
 266  
 267  
 268  
 269  
 270  
 271  
 272  
 273  
 274  
 275  
 276  
 277  
 278  
 279  
 280  
 281  
 282  
 283  
 284  
 285  
 286  
 287  
 288  
 289  
 290  
 291  
 292  
 293  
 294  
 295  
 296  
 297  
 298  
 299  
 300

REV	DATE	BY	CHKD
1	10/1/78	J. J. [unclear]	[unclear]
2	10/1/78	[unclear]	[unclear]
3	10/1/78	[unclear]	[unclear]
4	10/1/78	[unclear]	[unclear]
5	10/1/78	[unclear]	[unclear]
6	10/1/78	[unclear]	[unclear]
7	10/1/78	[unclear]	[unclear]
8	10/1/78	[unclear]	[unclear]
9	10/1/78	[unclear]	[unclear]
10	10/1/78	[unclear]	[unclear]
11	10/1/78	[unclear]	[unclear]
12	10/1/78	[unclear]	[unclear]
13	10/1/78	[unclear]	[unclear]
14	10/1/78	[unclear]	[unclear]
15	10/1/78	[unclear]	[unclear]
16	10/1/78	[unclear]	[unclear]
17	10/1/78	[unclear]	[unclear]
18	10/1/78	[unclear]	[unclear]
19	10/1/78	[unclear]	[unclear]
20	10/1/78	[unclear]	[unclear]
21	10/1/78	[unclear]	[unclear]
22	10/1/78	[unclear]	[unclear]
23	10/1/78	[unclear]	[unclear]
24	10/1/78	[unclear]	[unclear]
25	10/1/78	[unclear]	[unclear]
26	10/1/78	[unclear]	[unclear]
27	10/1/78	[unclear]	[unclear]
28	10/1/78	[unclear]	[unclear]
29	10/1/78	[unclear]	[unclear]
30	10/1/78	[unclear]	[unclear]
31	10/1/78	[unclear]	[unclear]
32	10/1/78	[unclear]	[unclear]
33	10/1/78	[unclear]	[unclear]
34	10/1/78	[unclear]	[unclear]
35	10/1/78	[unclear]	[unclear]
36	10/1/78	[unclear]	[unclear]
37	10/1/78	[unclear]	[unclear]
38	10/1/78	[unclear]	[unclear]
39	10/1/78	[unclear]	[unclear]
40	10/1/78	[unclear]	[unclear]
41	10/1/78	[unclear]	[unclear]
42	10/1/78	[unclear]	[unclear]
43	10/1/78	[unclear]	[unclear]
44	10/1/78	[unclear]	[unclear]
45	10/1/78	[unclear]	[unclear]
46	10/1/78	[unclear]	[unclear]
47	10/1/78	[unclear]	[unclear]
48	10/1/78	[unclear]	[unclear]
49	10/1/78	[unclear]	[unclear]
50	10/1/78	[unclear]	[unclear]

TO PAGE 2

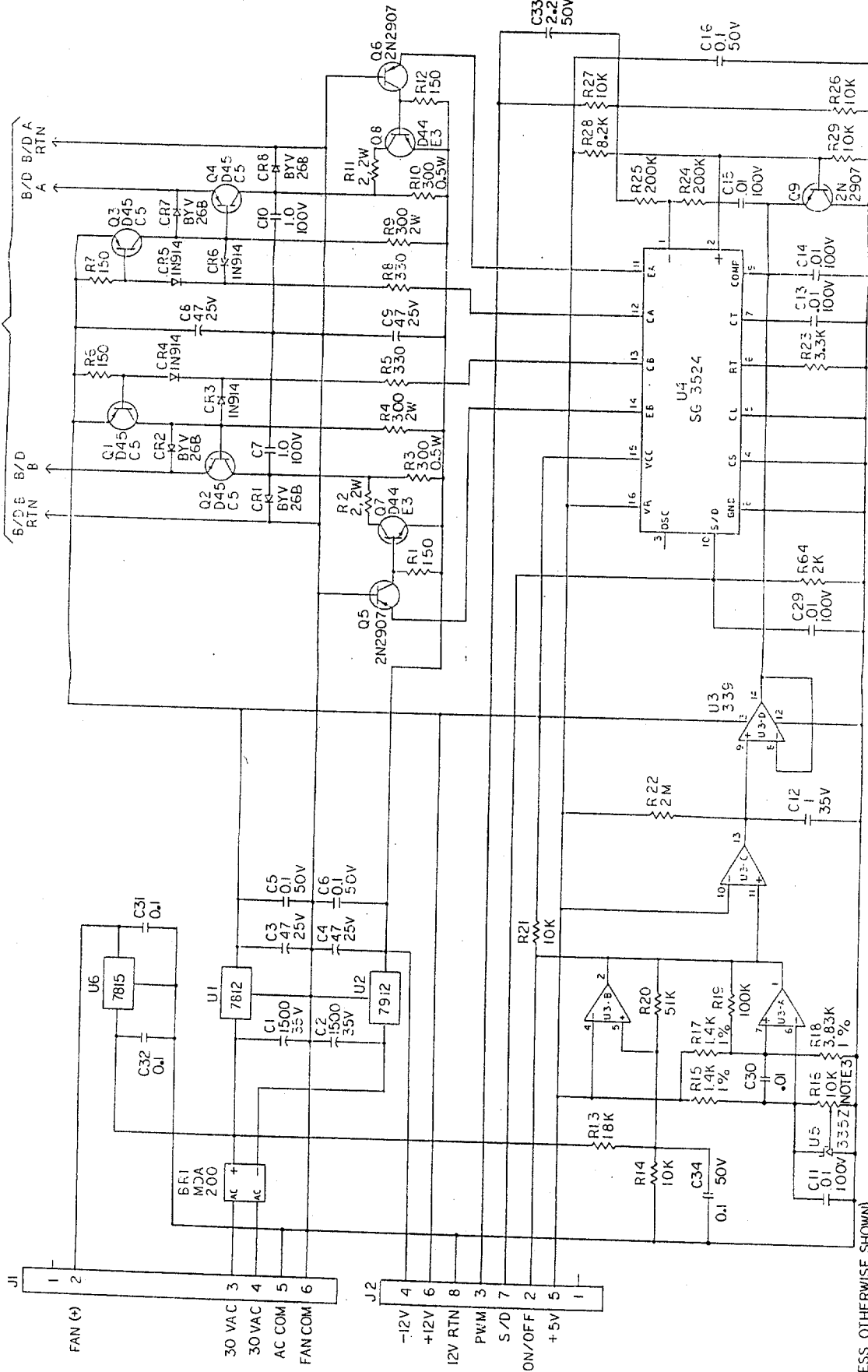

NOTES (UNLESS OTHERWISE SHOWN)  
 1- ALL CAPACITORS ARE IN MICROFARADS.  
 2- ALL RESISTORS ARE IN OHMS.  
 3- REFER TO L/M.

