

**Sorensen**



---

**Instruction  
Manual for  
ACR Series**

**Silicon Controlled  
Rectifier  
AC Regulators**

**This manual covers ACR models:**

<b>500</b>	<b>5000</b>
<b>1000</b>	<b>7500</b>
<b>2000</b>	<b>10,000</b>
<b>3000</b>	<b>15,000</b>



FIVE-YEAR WARRANTY

Sorensen Company warrants all parts of equipment of its manufacture, except special purpose tubes and semi-conductor devices which carry their own manufacturer's warranty, to be free from defects caused by faulty material or poor workmanship. Sorensen Company warrants its products to conform to applicable commercial or military specifications when confirmed on the Order Acknowledgment form to be free from defects caused by faulty material or poor workmanship. Sorensen Company's obligation is limited under the warranty to repair or replacement of products in kind, or at its option to issuance of a credit of original purchase price. Returns must be accompanied by a Sorensen Company Return Material Authorization form and conform to standard conditions for adjustment. The aforesaid warranty shall expire five (5) years following the last day of the month of shipment from Sorensen Company's plant. The foregoing states the entire warranty extended by Sorensen Company. No other warranty, expressed or implied, is made and, specifically, Sorensen Company makes no warranty of merchantability or fitness for any purpose. In no case shall Sorensen Company be liable for any special or consequential damages. Authorization must be obtained prior to return of defective items.

SORENSEN COMPANY

## TABLE OF CONTENTS

<u>Section</u>		<u>Page No.</u>
	Warranty.....	ii
	Sorensen Service Representatives.....	final page
1. 1.	SPECIFICATIONS	
	Electrical.....	1-1
	Mechanical.....	1-1
	Specification Notes.....	1-2
2. 2.	INSTALLATION AND OPERATION	
	2.1 Terminals and Controls.....	2-1
	2.2 Remote Sensing.....	2-3
	2.3 Programming.....	2-4
3. 3.	PRINCIPLES OF OPERATION	
	3.1 Block Diagram Analysis.....	3-1
	3.2 Main Power Circuit.....	3-1
	3.3 Phase Relationship.....	3-2
	3.4 Control Circuits.....	3-2
	3.5 Sawtooth Generator.....	3-2
	3.6 Mixer.....	3-3
	3.7 Schmitt Trigger.....	3-3
	3.8 Squaring Network.....	3-3
	3.9 DC Amplifier.....	3-3
	3.10 Overvoltage Protection.....	3-4
	3.11 Undervoltage Protection.....	3-4
	3.12 Overcurrent Protection.....	3-4
4. 4.	MAINTENANCE AND REPAIR	
	4.1 General.....	4-1
	4.2 Troubleshooting.....	4-1
5. 5.	DRAWINGS AND PARTS LIST	
	5.1 General.....	5-1
	5.2 Parts List Data.....	5-1

## LIST OF ILLUSTRATIONS

<u>Figure No.</u>	<u>Title</u>	<u>Page No.</u>
1	Input Voltage Range.....	1-2
2	Terminal Board Connections.....	2-2
3	ACR Block Diagram.....	3-1
4	Phase Relationship.....	3-2
5	ACR 1000 Schematic Diagram(Typ. ACR 500, 2000, 3000)	5-3
6	ACR 5000 Schematic Diagram.....	5-4
7	ACR 10000 Schematic Diagram (Typ. ACR 7500, 15000)..	5-5
8	ACR Printed-Circuit Board (Typ. All Units).....	5-6

## LIST OF TABLES

ACR Specifications.....	1-1
ACR Troubleshooting.....	4-1
Replaceable Parts List.....	5-7

# 1. SPECIFICATIONS

## ACR: Electrical Specifications

**Remote Programming:** 10 ohms per volt (Typ.)

**Input Power Factor (Typical):** 0.75

**Remote Sensing:** All models 1.5 volts drop maximum per load lead.

**RFI:** Meets MIL-I-26600 specifications for Class III equipment.

Model	ACR500	ACR1000	ACR2000	ACR3000	ACR5000	ACR7500	ACR10,000	ACR15,000	
<b>Output Power*</b>	<b>Voltage (Vac)</b>	110 to 120 Vac, Single Phase							
	<b>k VA Range</b>	0-.50	0-1.0	0-2.0	0-3.0	0-5.0	0-7.5	0-10.0	0-15.0
<b>Voltage Regulation<sup>1</sup></b>	<b>Line</b>	±0.1%			±0.15%				
	<b>Load</b>	±0.1%			±0.15%				
<b>Resolution</b>	0.05% of E <sub>o</sub>								
<b>Load Power Factor</b>	Unity to zero lag <sup>2</sup>								
<b>Harmonic Distortion</b>	3% maximum (introduced by regulator) <sup>6</sup>								
<b>Response Time</b>	30 ms <sup>3</sup>					50 ms <sup>3</sup>			
<b>Operating Temperature Range</b>	0°C to +50°C								
<b>Storage Temperature</b>	-40°C to +85°C								
<b>Drift</b>	0.05% for 8 hours (after 30 minute warmup) <sup>4</sup>								
<b>Temperature Coefficient</b>	0.015% E <sub>o</sub> /°C				0.03% E <sub>o</sub> /°C				
<b>Meter (2% accuracy)</b>	Output voltmeter standard								
<b>Input Power</b>	<b>Voltage</b>	95 to 130 Vac, Single Phase							
	<b>Maximum Current (Aac)</b>	7	14	26	39	63	94	123	183
	<b>Frequency</b>	50/60Hz <sup>5</sup>							
<b>% Efficiency (full VA)</b>	84	86	88	90	92	93	94	95	

\*ACR units may be connected in multiple to supply regulated three phase power (Write for Application Note PAN ACR-2)

### Notes:

- For full load change or ±10% line voltage change.
- For 7.5 kVA and larger models, the input voltage range is reduced to 100-130 Vac for power factor loads below 0.7 lagging.
- The speed to recover to 63% of the peak deviation of the transient caused by maximum line or load changes. Complete recovery may be from 1 to 8 cycles, depending on the magnitude of line or load change or up to 10 cycles for a simultaneous combination of worst-case line and load changes.
- With constant line, load and ambient temperature.
- May be operated from 47 to 53 Hz or 57-63 Hz. All units are factory adjusted for optimum 60 Hz performance and may be readjusted for optimum 50 Hz performance.
- Harmonic distortion measured at nominal 60 Hz or 50 Hz.

## ACR: Mechanical Specifications

Model Number	Dimensions: Inches (mm)				Weight: Lbs (Kg)
	Width	Height	Depth	Rack Height	
500	15(381)*	5(127)	9(228.6)	5 1/4(133.4)	30(13.6)
1000	19(483)	5 1/4(133.4)	11(279.4)	5 1/4(133.4)	45(20.4)
2000	19(483)	5 1/4(133.4)	14(355.6)	5 1/4(133.4)	65(29.5)
3000	19(483)	7(177.8)	15(381)	7(177.8)	85(38.5)
5000	19(483)	7(177.8)	20(508)	7(177.8)	145(65.8)
7500	19(483)	12 7/32(310.4)	20(508)	12 7/32(310.4)	170(77.1)
10,000	19(483)	12 7/32(310.4)	20(508)	12 7/32(310.4)	190(86.2)
15,000	19(483)	12 7/32(310.4)	20(508)	12 7/32(310.4)	275(124.7)

\*19 inch (483 mm) Adapter (Rack) Panel is available.

## SPECIFICATION NOTES

### FREQUENCY RANGE

ACR REGULATORS MAY BE OPERATED OVER AN INPUT RANGE OF 57 TO 63, OR 47 TO 53 HZ, BUT SPECIFICATIONS ARE GUARANTEED ONLY AT 60 OR 50 HZ. DISTORTION WILL INCREASE AS THE FREQUENCY IS VARIED FROM THE NOMINAL 60 OR 50 HZ, AND VOLTAGE REGULATION ACCURACY WILL BE REDUCED. OPERATION AT 50 HZ REQUIRES TAP CHANGES ON HARMONIC FILTERS L3 AND L4, AND L8 (WHERE APPLICABLE).

### TIME CONSTANT

WHEN AN ABRUPT CHANGE OCCURS IN THE INPUT VOLTAGE OR OUTPUT LOAD, AN INSTANTANEOUS CHANGE IN OUTPUT VOLTAGE OCCURS. THIS CHANGE IS QUICKLY SUPPRESSED BY THE REGULATING ACTION OF THIS REGULATOR. THE TIME CONSTANT OF ACR REGULATORS IS THE SPEED TO RECOVER TO 63% OF THE PEAK DEVIATION OF THE TRANSIENT CAUSED BY MAXIMUM LINE OR LOAD CHANGES. COMPLETE RECOVERY MAY BE FROM 1 TO 8 CYCLES DEPENDING ON THE MAGNITUDE OF LINE OR LOAD CHANGE, OR UP TO 10 CYCLES FOR A SIMULTANEOUS COMBINATION OF WORST-CASE LINE AND LOAD CHANGES.

SINCE RMS RECOVERY TIME OBSERVATIONS ARE DIFFICULT TO OBTAIN, PEAK DEVIATIONS ARE USED AS ESTIMATES FOR TRANSIENT RECOVERY TIME. HOWEVER, IT IS POSSIBLE FOR THE PEAK VALUE OF THE VOLTAGE WAVE TO PERMANENTLY CHANGE AS MUCH AS 9% AFTER A LOAD CHANGE (EVEN THOUGH THE RMS VALUE REMAINS WITHIN A  $\pm 0.1\%$  BAND). BY SPECIFYING TIME CONSTANT OF RESPONSE WE TEND TO AVOID THIS AMBIGUITY BETWEEN PEAK AND RMS READING.

### REGULATION ACCURACY

REGULATION IS SPECIFIED AS  $\pm X\%$  ABOUT AN ARBITRARY POINT. AS THIS VALUE CAN BE EITHER ALL POSITIVE OR ALL NEGATIVE FROM THE CHOSEN POINT, THE OUTPUT IS KEPT WITHIN A BANDWIDTH OF  $2 X\%$  RMS. DETECTION OF RMS REGULATION WITH RECTIFIER TYPE VOLTMETERS, VTVM PEAK VOLTMETERS, OR OSCILLOSCOPE OBSERVATION, MAY BE IN ERROR. USE ONLY THERMOCOUPLE OR DYNAMOMETER TYPE VOLTMETERS TO OBSERVE REGULATION.

### INPUT VOLTAGE

THE SPECIFIED INPUT VOLTAGE RANGE IS NOT GENERALLY AFFECTED BY NOMINAL (115 VOLTS) OUTPUT VOLTAGE SETTING, INPUT FREQUENCY OR LOAD POWER FACTOR. HOWEVER, THERE IS A VARIATION DUE TO ALL OF THESE QUANTITIES AS SHOWN IN FIGURE 1.

### OUTPUT DISTORTION (TYPICAL)

OUTPUT DISTORTION VARIES TO A CERTAIN EXTENT WITH LINE AND LOAD MAGNITUDE, AND POWER FACTOR. TYPICALLY, FOR LOADS BETWEEN 1/4 AND FULL LOAD AND 1.0 AND 0.7 POWER FACTOR, FOR LINE VOLTAGE EXCURSIONS BETWEEN 105 AND 125 VOLTS, AND FOR INPUT DISTORTION LESS THAN 2%, THE OUTPUT DISTORTION WILL NOT EXCEED 3%.

### INPUT-OUTPUT ISOLATION

THE ACR SERIES DOES NOT PROVIDE FOR INPUT-OUTPUT ISOLATION. ACR'S HAVE A COMMON INPUT AND OUTPUT LINE WHICH ACTS SIMILAR TO AN AUTO-TRANSFORMER.

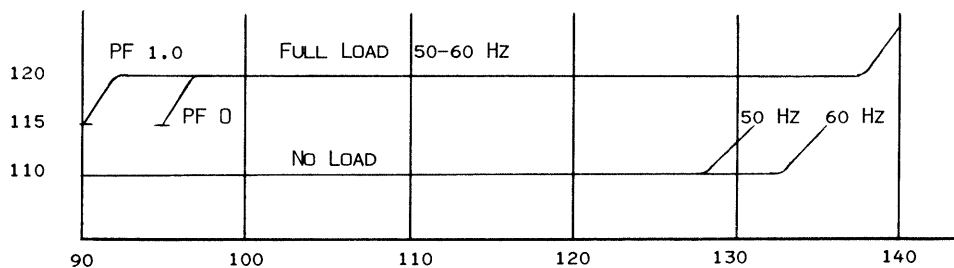

Figure 1. Input Voltage Range

## 2. I N S T A L L A T I O N A N D O P E R A T I O N

### 2.1 TERMINALS AND CONTROLS

#### 2.1.1. Input Power Connection

The input power is applied to the input terminal board at the rear of the unit. On small VA units, a line cord is supplied. Always connect neutral wire to "common" terminal on the terminal board. See Figure 2 for terminal connections.

#### 2.1.2. Input Frequency Conversion

To convert from 60 to 50-Hz operation, move wire(s) from terminal 2 to terminal 3 of L3 and L4. In addition, for 7500 VA and larger models, relocate wire(s) from terminal 2 to terminal 3 on choke L8.

#### 2.1.3. Output Power Connections

Output terminals at the rear of the unit provide for connecting a-c power output, remote sensing and voltage programming. See Figure 2 for terminal arrangement.

#### 2.1.4. Panel Lamp

The panel lamp indicates the presence of output power.

#### 2.1.5. Voltmeter

Units may be purchased with an optional voltmeter (refer to parts list).

#### 2.1.6. Controls

The 5000 VA and smaller models have an output voltage adjustment potentiometer and an on/off switch (S1) or circuit breaker (CB1) on the front panel. The circuit breaker on higher VA models protects the SCR's.

7500 VA and larger models have an output voltage adjustment potentiometer, an overload reset (CB2), a control circuit breaker (CB1), and control-circuit fuse F1, all on the front panel.

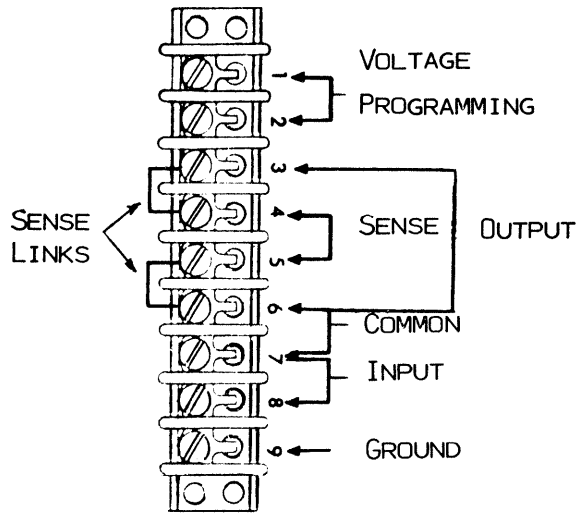

Rear Panel Terminal Layout, ACR 500 and 1000

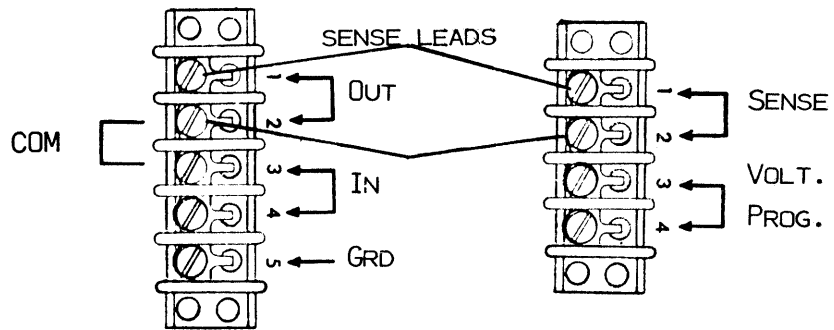

Rear Panel Terminal Layout, ACR 2000, 3000 and 5000

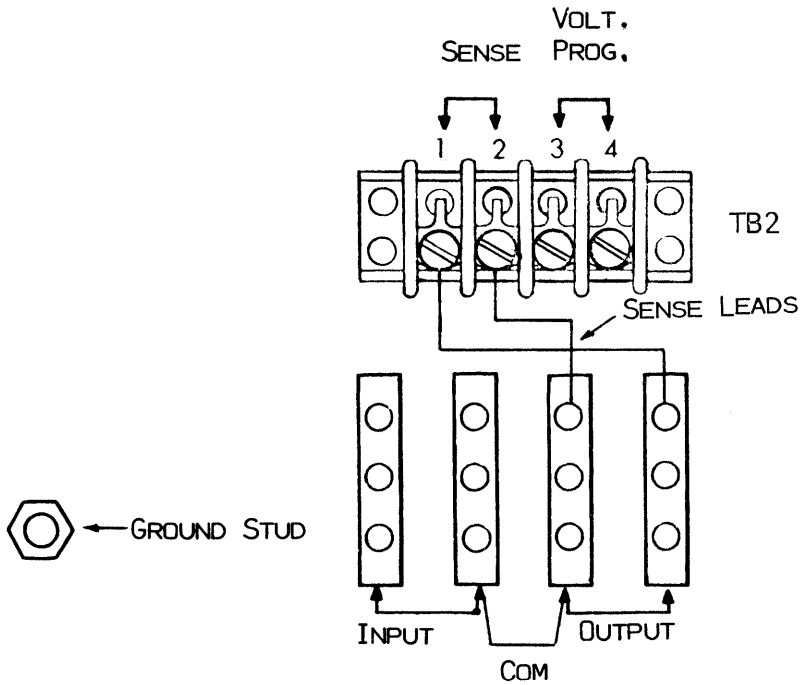

Rear Panel Terminal Layout, ACR 7500, 10000 and 15000

Figure 2. Terminal Board Connections

### 2.1.7. Protective Devices (Refer to schematic diagram; Figure 5)

The 500 and 1000 VA models have a thermal fuse (F1 on front panel) to protect against overloads considerably in excess (approximately 500%) of the rated capacity.

The 2000, 3000, and 5000 VA models are protected by overcurrent breaker CB1 (on the front panel) and thermal breaker CB2 (red reset button on rear panel).

The 1000, 2000, 3000 and 5000 VA models have an internal fuse (F2 on the rear panel) to protect the SCR's against amplifier failure or internal shorts.

The 7500, 10000 and 15000 VA models are protected by thermal overload breaker CB2 (reset push-button), control power breaker CB1 (to protect the SCR's) and control circuit fuse F1. All of these devices are located on the front panel.

### 2.1.8. Grounding

The "ground" connection on the terminal board is internally connected to the chassis, and should always be connected to the power line ground for personnel safety.

## 2.2. REMOTE SENSING

The ACR supply has provisions for regulating the output voltage at a load remote from the power supply. This is accomplished by removing the links between the sensing and output terminals, and running leads from the sensing terminals to the remote load. The following precautions must, however, be observed.

1. Use twisted wires or shielded cable for sensing leads in order to minimize pick-up.
2. The power leads must be chosen for a maximum of 1.5-volt drop in each power lead from the supply terminals to the sensing point.
3. The rated VA output of the supply applies at the output terminals. Any lead drops must be subtracted from these ratings to determine the output at the remote load.
4. "Open" sensing leads can result in low output or blown fuses. Be sure sensing leads are properly connected and securely tightened.

## 2.3. PROGRAMMING

The ACR units have provision for external programming of output voltage.

### 2.3.1. Voltage

The programming sensitivity is 10 ohms/volt. Tolerance is approximately  $\pm 3\%$ .

To program the output voltage, the voltage programming link is removed, and the program resistor is inserted in its place.

The front panel output control is in series with the programming terminals so that the front panel control may be used to set an initial output condition, with the programming resistance used to change this initial condition; or the front panel control may be set to zero so that complete control of the output voltage is achieved with the programming resistance.

In order to maintain the temperature coefficient and stability specified for the unit, the programming resistance should be a wire-wound resistor with a low temperature coefficient ( $\pm 150\text{PPM}$ ), or should be maintained in a constant ambient.

Note that the output voltage does not appear across the programming resistor as in many other types of supplies. The programming resistance in the ACR unit sees a constant current of approximately 5 millamperes.

#### CAUTION

*If an "open" exists between terminals 1 and 2, the supply will go to low output and the input circuit breaker may trip.*

### 2.3.2. Current

The current limit is factory adjusted to 120% of the rated output current, and is not externally programmable.

#### NOTE

*At "turn-on," the output experiences a low-voltage (90-100 volts) delay of 2 to 10 seconds before it reaches the normal output voltage level. This is the time necessary for the control amplifier to reach its operating level.*

### 3. P R I N C I P L E S O F O P E R A T I O N

#### 3.1 BLOCK DIAGRAM ANALYSIS

The operation of this instrument can best be understood by referring to block diagram Figure 3 and to schematic diagram, Figure 5.

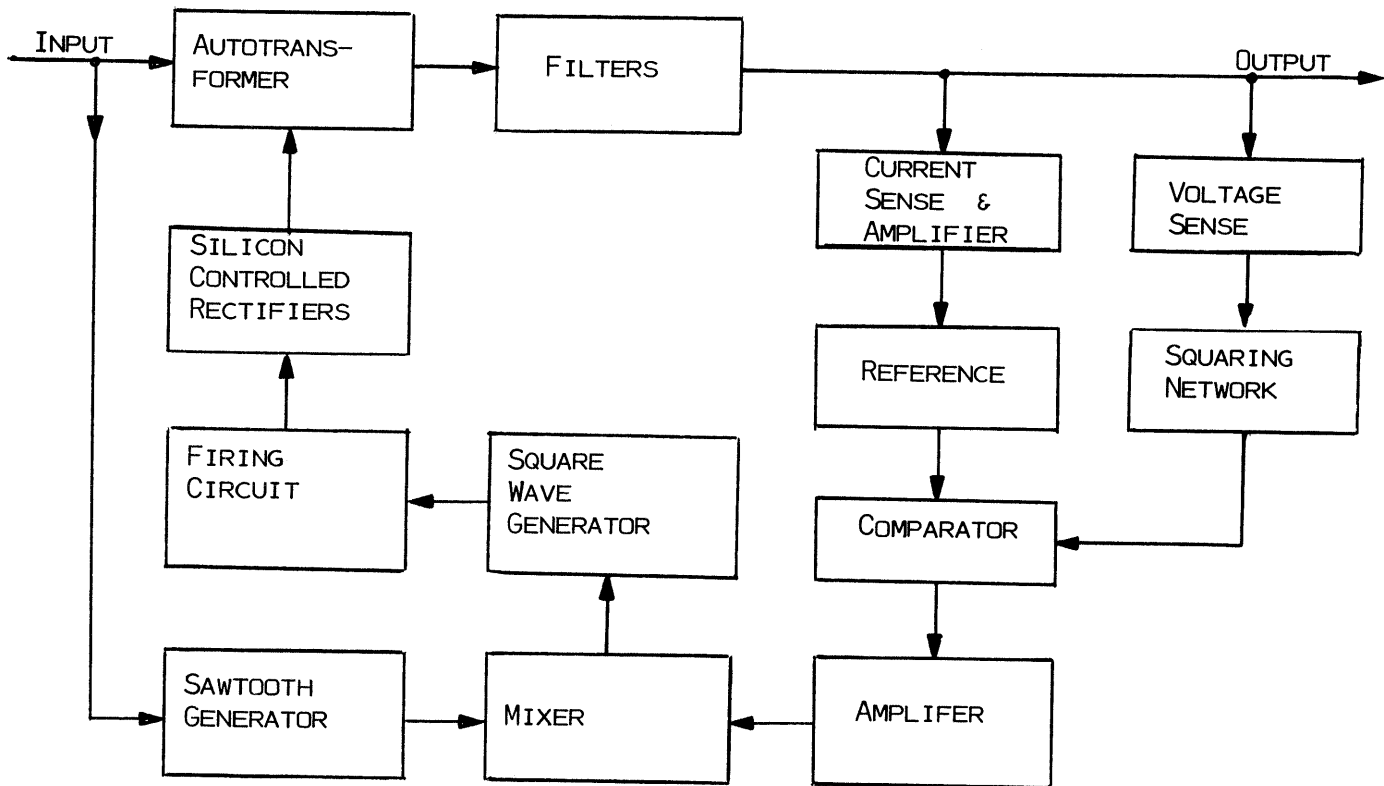

Figure 3. ACR Block Diagram

#### 3.2 MAIN POWER CIRCUIT

Input voltage is applied to the primary of the main transformer T1 which is filtered by L1, L3, C1 and C2 to supply the ac output voltage. This main power supply is regulated by controlled rectifiers CR1 and CR2 in series with the primary circuit of transformer T1. The controlled rectifiers cause phase delay in the correct amount to compensate for any deviation in the output voltage. Vector diagrams of the various voltages are shown in Figure 4.

### 3.3 PHASE RELATIONSHIP

The phase relationships that exist in the power circuit are shown by the following vector diagrams for both high and low input voltages.

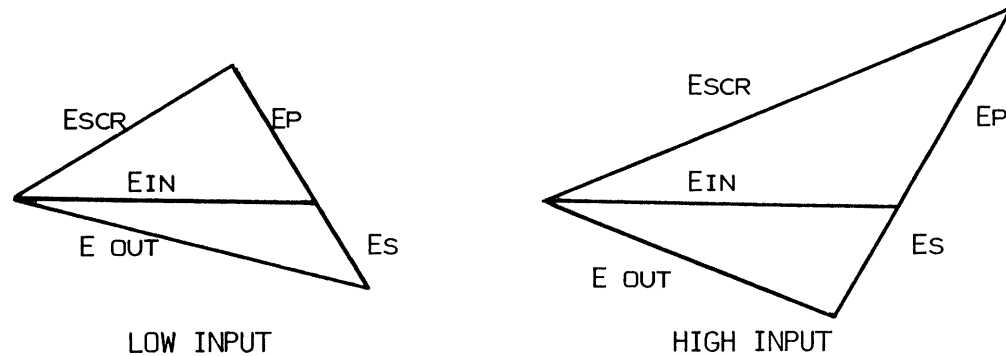

Figure 4. Phase Relationship

Escr	Voltage across the silicon controlled rectifier and choke
Ein	Input voltage
Eout	Regulated output voltage
Ep	Voltage across primary of the autotransformer
Es	Voltage across secondary of the autotransformer.

### 3.4 CONTROL CIRCUITS

The amplifier operating the controlled rectifier first generates a sawtooth waveform. This signal is then superimposed upon a dc voltage. Adjusting the amplitude of the dc voltage provides a variable operating point as a function of the time.

Transistors Q7 through Q13 and their associated circuitry provide the proper waveforms and pulses with the correct timing to fire the controlled rectifiers. Q2, Q4 and Q5 circuitry produces a dc voltage of the correct value on which is superimposed the sawtooth wave.

### 3.5 SAWTOOTH GENERATOR

The ac voltage at the secondary of transformer T2 is rectified by CR14 and CR15, and is then applied to the base of transistor Q7. RC network R29 and C15 comprise the sawtooth generator. The waveform across R31 is as shown below.

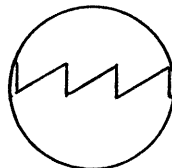

### 3.6 MIXER

The sawtooth waveform is fed to emitter-follower Q8 and coupled to mixer-block resistor R32. Mixed dc and the sawtooth signal are used to fire Schmitt trigger circuit Q9/Q10. (See wave shape on schematic.)

### 3.7 SCHMITT TRIGGER

Before the Schmitt trigger fires, Q10 is conducting and current flows through R36. Therefore, Q11, 12 and 13 are back-biased and cut off. When the voltage from the mixer fires the Schmitt trigger, Q10 cuts off and Q9 saturates, which in turn saturates Q11 through Q13. Q12 or Q13 can conduct only when the collectors are positive with respect to the base and emitter. Depending on the incoming line phase, one or the other will fire pulse transformer T5 or T6 which, in turn, fires the appropriate SCR. The square wave firing signal shown on the circuit diagram can be observed across R39.

### 3.8 SQUARING NETWORK

The network consisting of Q6 and CR9 and their associated circuitry takes the rectified dc signal from sensing transformer T3 and forms it into a waveform (shown below) which is applied across R19 and R20. R20 is the output voltage adjust potentiometer.

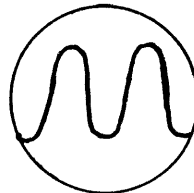

The signal is proportional to the root-mean-square of the output voltage.

### 3.9 DC AMPLIFIER

The squared output voltage signal is applied to the input of Q5. A reference voltage meanwhile is developed at the base of Q4 by zener CR6 and the voltage divider R7-R8.\* Q4-Q5 form a differential amplifier which amplifies the error signals developed by a comparison of the reference signal and the RMS signal developed across R19 and R20.

The output of the differential amplifier is developed across R10 and fed to the base of Q2. Voltage amplifier Q2 supplies the required current into mixer R32. This fires the Schmitt trigger at the proper point to insure the correct phase delay in the primary of T1.

\*R8 sets the "base" level of the reference voltage.

### 3.10 OVERVOLTAGE PROTECTION

Q3 and its associated circuitry serves several purposes. In case of line voltage failures (due to lightning or short circuits on the line) where the line voltage momentarily drops well below 95 volts and then returns to its original value within 500 milliseconds, Q3 prevents the output voltage from overshooting. Secondly, Q3 prevents overshoot from occurring in case of loss of sense. Lastly, in case of short circuits where the output voltage dips considerably, Q3 serves as "back up" protection for current limiting circuit.

### 3.11 UNDERVOLTAGE PROTECTION

If undervoltage protection is desired, one of two alternatives is available:

1. Where "no voltage" is more desirable than "low voltage" (60-90 volts), an ordinary manual reset, solenoid-type contactor may be used between the regulator and load.
2. Where voltage variations less than 95 volts cannot be tolerated, a transfer relay may be used to transfer the output of the unit to the line in case of overload or electronic failure. Contact factory for availability and specifications.

### 3.12 OVERCURRENT PROTECTION

Resistor R1 provides an output current signal to current-sensing transformer T4 which, by means of Q1 and voltage divider R3/R4, can adjust the reference voltage across R8 to lower the output voltage in case of over-currents which may tend to damage the SCR's. Where the over-current signal is short lived (such as tungsten lamp loads, transformer in-rush currents or small motors starting), the reference voltage recharges to its original value if the current drops below rated output. For heavier, sustained overloads, the output voltage remains at a very low value (typically 60-80 volts). Where the load impedance represents a 300-1000% overload, output fuse F1 will blow, or circuit breaker CB1 will trip. On most units, SCR fuse F2 is incorporated to protect the SCR's from damage in case of misfiring. F2 should be checked any time the circuit breaker trips, especially if the output drops to 60 to 90 volts.\* If the thermal circuit breaker CB2 opens (no output voltage), it can be reset after a few minutes "cooling time".

#### Caution

*For installations where large tungsten lamp loads, induction motors, or transformer input power supplies are switched on and off, only solenoid-type starters and relays with built-in time delays are recommended on the regulated voltage circuit.*

\* Use only Chase Shawmut "amp trap" fuses when replacing F2.

## 4. MAINTENANCE AND REPAIR

### 4.1 GENERAL

During normal life, this instrument requires no maintenance other than the care afforded similar equipment. It is suggested that dust and any other foreign matter be removed periodically, exercising care to prevent damage to the instrument by cleaning tools or excessively strong air blasts.

#### Caution

*Keep Terminal Board Links tight at all times*

### 4.2 TROUBLE SHOOTING

Only qualified personnel familiar with transistorized regulator circuitry should attempt the repair of the unit. Major servicing should be done only by the factory or one of its representatives. Due to the interchangeable control circuits, replacement plug-in control circuits can be obtained from the factory or a representative in a few days time. It is recommended that this procedure be followed except in an extreme emergency.

#### Caution

*SCR heat sinks, transformers, and ac capacitor terminals are above ground potential. Never touch without disconnecting unit power.*

<u>Symptom</u>	<u>Probable Cause</u>	<u>Procedure for Repair</u>
1. No output	a. Check F1 or CB2 b. Loose wires at the terminal board or at the circuit breaker	a. Replace or reset. b. Check and secure Q1 to Q6. Replace if necessary.
2. Low Output	a. Overload b. Fuse F2 blown c. Transistor Q1 or Q3 d. Loss of sensing	a. Check output current and compare with unit rating. Reduce load to rating. b. Check and replace with exact replacement. c. Check and replace. d. Check sensing connections and waveform across R19. If no waveform appears, check transistor Q6 and the wiring to transformer T3.

<u>Symptom</u>	<u>Probable Cause</u>	<u>Procedure for Repair</u>
2. Low Output (cond't)	<ul style="list-style-type: none"> <li>e. Defective SCR</li> <li>f. Defective sync</li>   <li>g. Defective amplifier</li>            <li>h. Transistors not properly seated in their sockets.</li> </ul>	<ul style="list-style-type: none"> <li>e. Check and replace.</li> <li>f. If no sawtooth at R1, check Q7 and Q8 and replace.</li> <li>g. Check reference supply across CR22 (12 volts). Check waveforms at points indicated on schematic diagram. If a poor sawtooth waveform appears across R32, slowly adjust R8 until it reforms and the firing square wave appears across R39. If it does not, remove Q2 from its socket and temporarily replace with variable resistor of approximately 100K (from emitter to collector). Slowly adjust resistor until the firing square wave appears. Then check Q1 to Q6.</li> <li>h. Check and reset.</li> </ul>
3. High Output	<ul style="list-style-type: none"> <li>a. Shorted SCR</li> <li>b. Defective transistor in amplifier or firing circuit</li> </ul>	<ul style="list-style-type: none"> <li>a. Check and replace.</li> <li>b. Proceed as in procedure 2g after removing Q2. If the resistor restores firing, check transistors Q1 to Q6 and replace where necessary. If the resistor does not restore proper firing, check transistors Q9 to Q13 and replace where necessary.</li> </ul>
4. Poor Regulation (must be checked with thermocouple or dynamometer type voltmeter)	<ul style="list-style-type: none"> <li>a. Peak current overload</li> <li>b. High input distortion (more than 5%)</li> <li>c. Defective current limiting</li> </ul>	<ul style="list-style-type: none"> <li>a. Check output current and waveform. If waveform is peaked due to capacitance on the line, consult factory</li> <li>b. Check input voltage waveform. If considerably distorted, consult factory.</li> <li>c. If current is over 110% and not peaked, reduce to 100% and recheck regulation. If still poor, remove Q1. If this clears up the trouble,</li> </ul>

Symptom

Probable Cause

Procedure for Repair

4. Poor Regulation  
(cont'd)

check Q1 for proper operation.  
Replace Q1 and readjust R4  
until regulation is within  
band specified.

5. Erratic Operation

a. Defective SCR or  
Fuse F2

a. Short out SCR fuse F2 and  
apply a small output load.  
If the unit regulates properly,  
replace fuse with exact re-  
placement. If the trouble  
persists, check the forward  
breakover voltage of the SCR.  
This may be done on an SCR  
tester such as the Solitron  
R200 or an equivalent. If  
the forward breakover voltage  
is less than 400 Vdc, replace  
the SCR.

b. Loss of sync  
c. Zener diode CR22 open

b. See procedure 2F.  
c. Check voltage across CR22.  
If different than  $12V \pm 10\%$   
replace CR22.



## 5. D R A W I N G S A N D P A R T S L I S T

### 5.1 GENERAL

This section provides a table of replaceable parts, keyed by circuit symbol to the schematic diagrams in Figures 5-1A, B and C. Figure 5-2 illustrates the component layout on a printed-circuit board, typical of those used in the ACR regulator.

### 5.2 PARTS LIST

Components in the parts list are tabulated alpha/numerically by circuit symbol. Separate columns are provided for each ACR model. A numerical value in the column indicates the quantity of the component used in a particular model. Included are the Sorensen and the recommended manufacturer part numbers. A coded list of representative manufacturers is presented in paragraph 5.3.

When ordering parts directly from Sorensen, include the model number and Sorensen part number. Call (603) 668-4500, or direct order to:

Sorensen Company  
Replacement Parts Dept.  
676 Island Pond Road  
Manchester, N. H. 03103

### 5.3 MANUFACTURER PARTS LIST CODES

The following manufacturer codes are used throughout the following parts list:

AB	Allen Bradley Co.
AC	Acushnet Capacitor Co.
AX	Aerovox Corp.
BNS	Bourns, Incorporated
BUS	Bussman Mfg./Division McGraw-Edison
CD	Cornell-Dublier Corp.
CEN	Centra Lab
CG	Corning Glass Works
CH	Cutler-Hammer
CL	Clarostat Corp.
CS	Case-Shawnut

### 5.3 MANUFACTURER PARTS LIST CODES (cont'd)

GE	General Electric Company
HM	Heinemann Electric
IND	Industrial Devices
IR	International Rectifier
IRC	International Resistance Company
KEM	Kemet Division Union Carbide Corp.
LF	Littelfuse Corporation
MA	Motorola
SEM	Semtech Corporation
SP	Sprague Electric
SR	Sorensen Company
TI	Texas Instrument
WH	Westinghouse Semiconductor Division
WL	Ward Leonard





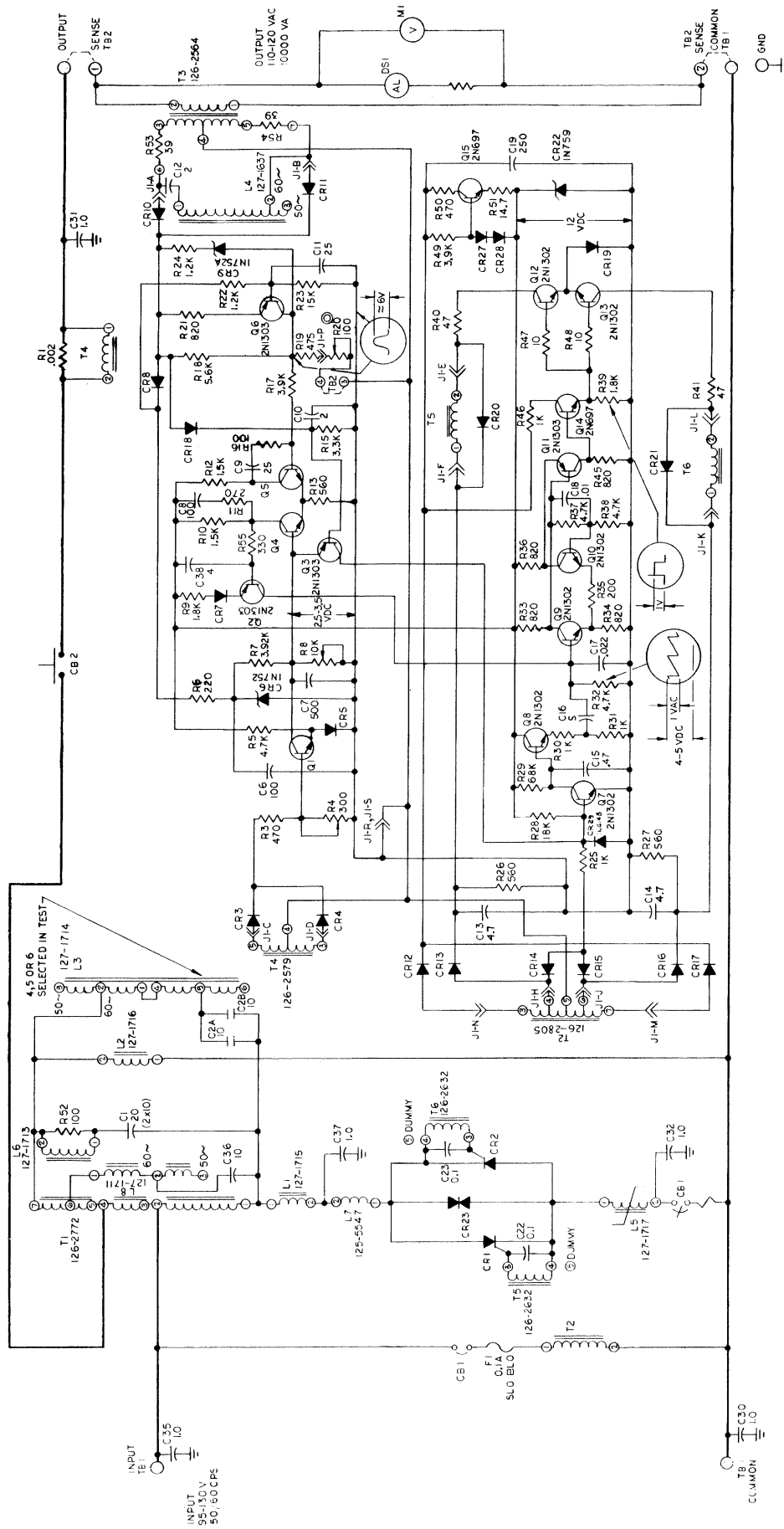

NOTES:  
 1. ALL VALUES EXPRESSED IN OHMS OR MICROSECONDS UNLESS OTHERWISE SPECIFIED.  
 2. Ⓞ DENOTES FRONT PANEL CONTROL.

Figure 5-1C, ACR 10000 Schematic Diagram  
 (Typical ACR 7500, 15000)

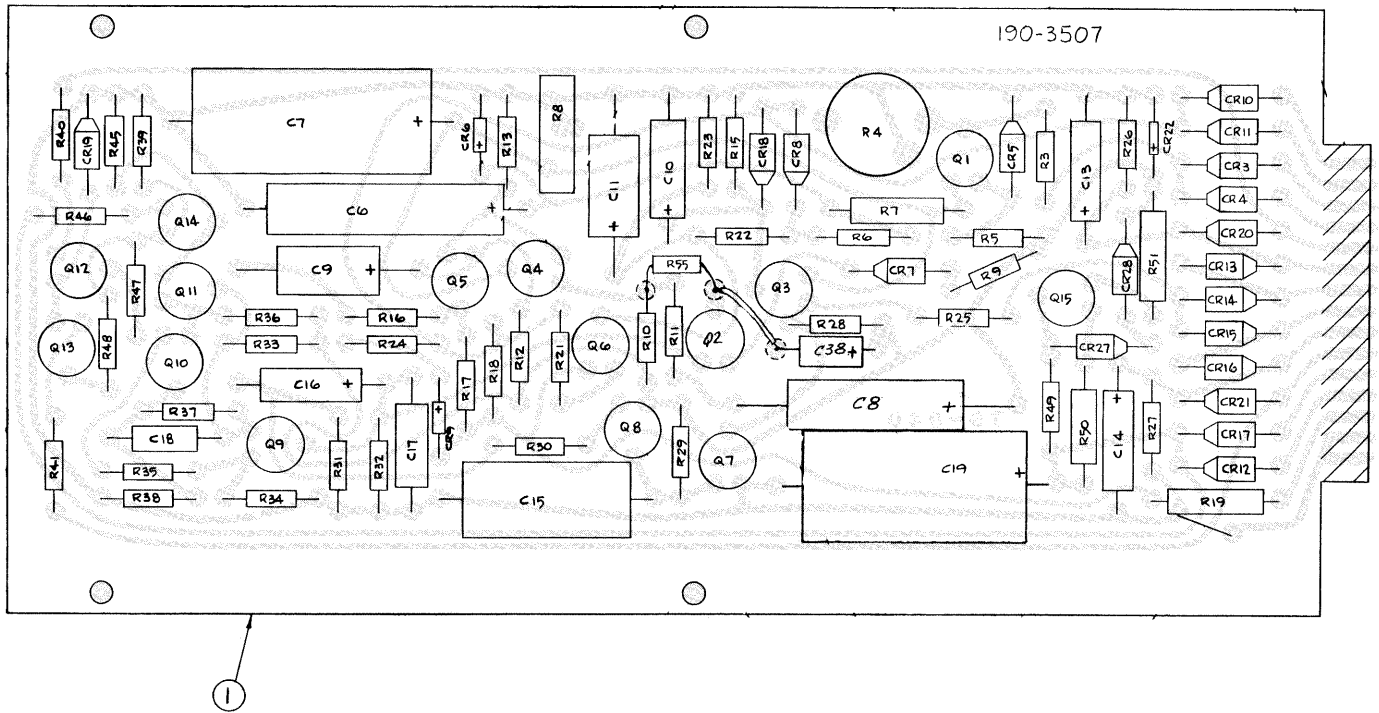

Figure 5-2, ACR Printed-Circuit Board  
(Typical All Units)

REPLACEABLE PARTS LIST  
ACR SERIES

CIRCUIT SYMBOL	ACR MODEL								DESCRIPTION	SORENSEN PART NUMBER	MANUFACTURER, TYPE
	500	1000	2000	3000	5000	7500	10000	15000			
									Capacitors (uF)		
C1	x	x	2	x	x	2	2	3	4, 440 Vac 10, 440 Vac 10, 440 Vac 25, 440 Vac 15, 660 Vac 7.5, 440 Vac 10, 440 Vac	24-540 24-541 24-541 1058530-1 1058529-1 24-566 24-541	SP, 200P SP, 200P SP, 200P AX, N94R AX, H94R GE, 49F SP, 200P
C2	x	x	x	x	x	x	2	2	4, 440Vac 10, 440Vac 5, 660Vac 7, 440Vac 8, 660Vac 15, 660Vac 10, 660Vac 15, 660Vac	24-540 24-541 24-3930-9 24-543 1058528-1 1058529-1 1058532-1 1058529-1	SP, 200P SP, 200P SP, RVC AX, P162F AX, H92R GE, 49F
C3	x	x	x	x	x	x	x	2	0.1, 200V Not used	24-2409-13	AX, P103F AC, V146XR
C4	x	x	x	x	x	x	x	x	0.1, 200V Not used	24-2409-13	AC, V146XR
C5	x	x	x	x	x	x	x	x	Not used		
C6	x	x	x	x	x	x	x	x	100, 25V	24-2279-14	SP, TE1211
C7	x	x	x	x	x	x	x	x	500, 12V	24-2284-4	SP, TVA
C8	x	x	x	x	x	x	x	x	100, 25V	24-2279-14	SP, TE1211
C9	x	x	x	x	x	x	x	x	25, 25V	24-2279-10	SP, TE1207
C10	x	x	x	x	x	x	x	x	2, 50V	24-2280-2	SP, TE1301
C11	x	x	x	x	x	x	x	x	25, 25V	24-2279-10	SP, TE1207
C12*	x	x	x	x	x	x	x	x	2, 200V	24-2409-21	AC, V146XR
C13	x	x	x	x	x	x	x	x	4.7, 50V	585071-37	KEM, T110B
C14	x	x	x	x	x	x	x	x	4.7, 50V	585071-37	KEM, T110B
C15	x	x	x	x	x	x	x	x	.47, 200V	24-2409-17	AC, V146XR
C16	x	x	x	x	x	x	x	x	5, 50V	24-2280-5	SP, TE1303
C17	x	x	x	x	x	x	x	x	0.022, 200V	24-2409-9	AC, V146XR
C18	x	x	x	x	x	x	x	x	0.068, 200V 0.01, 200V	24-2409-12 24-2409-7	AC, V146XR AC, V146XR
C19	x	x	x	x	x	x	x	x	250, 50V	24-2287-8	SP, TVA
C20	x	x	x	x	x	x	x	x	0.47, 600V 0.1, 200V Not used	166374-11 24-2409-13	CD, MMW AC, V146XR
C21	x	x	x	x	x	x	x	x	0.05, 500V 0.1, 200V Not used	24-2010 24-2409-13	CEN, 1D AC, V146XR
C22	x	x	x	x	x	x	x	x	0.47, 600V 0.1, 200V	166374-1 24-2409-13	CD, MMW AC, V146XR
C23	x	x	x	x	x	x	x	x	0.05, 500V 0.1, 200V	24-2010 24-2409-13	CEN, 1D AC, V146XR
C24	x	x	x	x	x	x	x	x	0.47, 600V 0.05, 500V	166374-1 24-2010	CD, MMW CEN, 1D
C25	x	x	x	x	x	x	x	x	Not used 1.0, 600V 0.47, 600V 0.47, 400V Not used	166374-13 24-2410-17 24-2411-17	CD, MMW AC, V146XR AC, V146XR

\*Matched set with L4 (Sorensen Part No. 190-3523)

REPLACEABLE PARTS LIST  
ACR SERIES

CIRCUIT SYMBOL	ACR MODEL								DESCRIPTION	SORENSEN PART NUMBER	MANUFACTURER, TYPE
	500	1000	2000	3000	5000	7500	10000	15000			
									<u>Capacitors (uF) (cont'd)</u>		
C26	x	x	x	x	x	x	x	x	Not used 0.47, 600V 0.05, 500V	24-2410-17 24-2010	AC, V146XR CEN, 1D
C27	x	x	x	x	x	x	x	x	Not used 1.0, 400V	24-2411-19	AC, V146XR
C28	x	x	x	x	x	x	x	x	Not used 0.05, 500V	24-2010	CEN, 1D
C29	x	x	x	x	x	x	x	x	Not used 0.47, 400V	24-2411-17	AC, V146XR
C30	x	x	x						Not used 0.47, 400V 0.47, 600V 0.1, 600V	24-2411-17 166374-11 166374-13	AC, V146XR CD, MMW CD, MMW
C31	x	x	x						Not used 1.0, 600V	166374-13	CD, MMW
C32	x	x	x						Not used 1.0, 600V	166374-13	CD, MMW
C33	x	x	x						Not used 0.05, 500V	166374-13	CD, MMW
C34	x	x	x						Not used 0.05, 500V	166374-13	CD, MMW
C35	x	x	x						Not used 1.0, 600V	166374-13	CD, MMW
C36	x	x	x						Not used 7.5, 440Vac 10, 440Vac	24-566 24-541	GE, 49F GE, 49F
C37	x	x	x						Not used 1.0, 600V	166374-13	CD, MMW
C38	x	x	x						Not used 40, 25V	24-2279-4	SP, TE1201.2
									<u>Circuit Breakers</u>		
CB1	x	x	x						Not used Input, 35A Input, 50A Input, 80A Input, 50A Input, 60A Input, 90A	92-309-3 92-309-4 92-315 92-328 92-326 92-332	TI, 4MC2103-35 TI, 4MC2-103-50 HM, 1163S HM, PAM12HK HM, PX0411TSHK HM, PX0411TSHK
CB2	x	x	x						Not used Thermal Overload, 25A Thermal Overload, 40A Thermal Overload, 70A Thermal Overload, 105A Thermal Overload, 150A Thermal Overload, 200A	92-312 92-313 92-314 92-327 92-325 92-331	TI, CM25 TI, CM40 TI, CLM70 TI, CLM105 TI, CLM150 TI, C7855-6

REPLACEABLE PARTS LIST  
ACR SERIES

CIRCUIT SYMBOL	ACR MODEL								DESCRIPTION	SORENSEN PART NUMBER	MANUFACTURER, TYPE
	500	1000	2000	3000	5000	7500	10000	15000			
									<u>Diodes</u>		
CR1&2	x	x		x					SCR	26-157	GE, C20D
			x	x					SCR	26-178-6	GE, C30DX7
					x				SCR	26-178-7	GE, C30EX7
						x			SCR	26-1005	WH, 209K
							x		SCR	26-197	GE, C52E
								x	Rectifier	587565-1	SEM, S11
CD3-5	x	x	x	x	x	x	x	x	Zener, 1N752	26-222	IR
CR6	x	x	x	x	x	x	x	x	Rectifier	587565-1	SEM, S11
CR7&8	x	x	x	x	x	x	x	x	Zener, 1N752A	588101-8	IR
CR9	x	x	x	x	x	x	x	x	Zener, 1N751A	26-204	IR
CR10-21	x	x	x	x	x	x	x	x	Rectifier	587565-1	SEM, S11
CR22	x	x		x	x				Zener, 1N4742A	588102-9	MA
			x			x	x	x	Zener, 1N759	26-221	MA
CR23	x	x							Thyrector	26-159	IR, 63-0420
			x	x					Rectifier, 368F	26-173-5	WH
					x				Rectifier, 1N1188A	587382-4	GE
CR24	x	x				x	x	x	Rectifier	26-617	IR, 63-0421
			x	x					Not used		
					x				Rectifier, 368F	26-173-5	WH
CR25	x	x				x	x	x	Rectifier, 1N1188AR	587382-9	GE
			x	x	x				Not used		
CR26	x	x				x	x	x	Rectifier	587565-1	SEM, S11
			x	x	x				Not used		
CR27	x	x							Rectifier	587565-1	SEM, S11
			x	x					Not used		
					x				Thyrector	26-159	IR, 63-0420
						x			Rectifier, 1N751A	26-204	MA
CR28	x	x	x	x					Rectifier	587565-1	SEM, S11
					x				Not used		
						x	x	x	Rectifier, 1N751A	26-204	MA
									Rectifier	587565-1	SEM, S11
DS1	x	x	x	x	x	x	x	x	<u>Pilot Lamp</u>	43-321	IND, IV-B
									<u>Fuses</u>		
F1	x								5A	42-444	LF, 314005
		x							10A	42-1809	
			x	x	x				Not used		
F2	x					x	x	x	0.1A SB	42-1202	BUS, MDL
		x							Not used		
			x	x					8A	42-3807	CS, A25X3
					x				20A	42-3808	CS, A25X20
									30A	42-3809	CS, A60X30

REPLACEABLE PARTS LIST  
ACR SERIES

CIRCUIT SYMBOL	ACR MODEL							DESCRIPTION	SORENSEN PART NUMBER	MANUFACTURER, TYPE
	500	1000	2000	3000	5000	7500	10000			
								<u>Chokes</u>		
L1	x							SCR	127-1598	SR
		x						SCR	127-1602	SR
			x					SCR	127-1612	SR
				x				SCR	127-1621	SR
					x			SCR	127-1618	SR
						x		SCR	127-1729	SR
							x	SCR	127-1715	SR
								SCR	127-1737	SR
L2	x							Load	127-1596	SR
		x						Load	127-1601	SR
			x					Load	127-1611	SR
				x				Load	127-1619	SR
					x			Load	127-1617	SR
						x		Load	127-1727	SR
							x	Load	127-1716	SR
								Load	127-1735	SR
L3	x							3rd Harm, Filter	127-1597	SR
		x						3rd Harm, Filter	127-1600	SR
			x					3rd Harm, Filter	127-1613	SR
				x				3rd Harm, Filter	127-1620	SR
					x			3rd Harm, Filter	127-1616	SR
						x		3rd Harm, Filter	127-1730	SR
							x	3rd Harm, Filter	127-1714	SR
								3rd Harm, Filter	127-1738	SR
L4*	x	x	x	x	x	x	x	5th Harm, Filter	127-1637	SR
L5	x							RFI Filter	125-5434	SR
		x						RFI Filter	125-5439	SR
			x					RFI Filter	125-5462	SR
				x				RFI Filter	125-5440	SR
					x			RFI Filter	125-5441	SR
						x		SCR, Choke	127-1726	SR
							x	SCR, Choke	127-1717	SR
								SCR, Choke	127-1734	SR
L6	x	x	x	x	x			Not used		
						x		7th Harm, Filter	127-1725	SR
							x	7th Harm, Filter	127-1713	SR
L7	x	x	x	x	x			7th Harm, Filter	127-1733	SR
						x		Not used		
							x	RFI Filter	125-5564	SR
L8								RFI Filter	125-5547	SR
	x	x	x	x	x			RFI Filter	125-5577	SR
						x		Not used		
						x	5th Harm, Filter	127-1728	SR	
							x	5th Harm, Filter	127-1711	SR
								5th Harm, Filter	127-1736	SR

\*Matched set with C12 (Sorensen Part No. 190-3523)

REPLACEABLE PARTS LIST  
ACR SERIES

CIRCUIT SYMBOL	ACR MODEL								DESCRIPTION	SORENSEN PART NUMBER	MANUFACTURER, TYPE	
	500	1000	2000	3000	5000	7500	10000	15000				
M1	x	x	x	x	x					<u>Voltmeter</u> Output, 0-150V Output, 0-150V	94-440-1 94-440-2	SR SR
Q1	x	x	x	x	x					<u>Transistors</u> 2N2926 2N2926	18-125-1 18-125-2	GE GE
Q2&3	x	x	x	x	x	x	x	x		2N1303	18-089	TI
Q4&5	x	x	x	x	x	x	x	x		2N2926	18-125-2	GE
Q6	x	x	x	x	x	x	x	x		2N1303	18-089	TI
Q7-10	x	x	x	x	x	x	x	x		2N1302	18-092	TI
Q11	x	x	x	x	x	x	x	x		2N1303	18-089	TI
Q12&13	x	x	x	x	x	x	x	x		2N1302	18-092	TI
Q14&15	x	x	x	x	x					Not used 2N697	18-115	TI
R1	x									<u>Resistors (ohms, 1/2W±10% unless noted)</u> 0.04 0.02 0.01 0.0066 0.004 0.003 0.002 0.0015	21-078 190-4103 190-3278 190-3280 190-3281 190-3519 190-3508 190-3515	SR SR SR SR SR SR SR SR
R2	x	x	x	x	x	x	x	x		Not used		
R3	x	x	x	x	x	x	x	x		470	280-1145P62	AB, EB
R4	x	x	x	x	x	x	x	x		300, 2W Variable	29-429	IRC, 110(CTS)
R5	x	x	x	x	x	x	x	x		4.7K	280-1145P98	AB, EB
R6	x	x	x	x	x	x	x	x		220	280-1145P50	AB, EB
R7	x	x	x	x	x	x	x	x		3.92K	28-1145	IRC, CEC(TO)
R8	x	x	x	x	x	x	x	x		10K, 2W Variable	586371-7	BNS, 3006
R9	x	x	x	x	x	x	x	x		1.8K	280-1145P83	AB, EB
R10	x	x	x	x	x	x	x	x		1.5K	280-1145P80	AB, EB
R11	x	x	x	x	x					180	280-1145P47	AB, EB
						x	x	x		270	27-1155	AB, EB
R12	x	x	x	x	x	x	x	x		1.5K	280-1145P80	AB, EB
R13	x	x	x	x	x	x	x	x		560	280-1145P65	AB, EB
R14	x	x	x	x	x					2.2K	280-1145P86	AB, EB
R15	x	x	x	x	x	x	x	x		Not used		
R16	x	x	x	x	x	x	x	x		3.3K, ±5%	280-1145P91	AB, EB
R17	x	x	x	x	x	x	x	x		100	280-1145P38	AB, EB
						x	x	x		3.9K	280-1145P95	AB, EB
					x					5.6K, ±5%	280-1145P100	AB, EB
R18	x	x	x	x		x	x	x		5.6K, ±5%	280-1145P100	AB, EB
					x					2.7K, ±5%	280-1145P88	AB, EB
R19	x	x	x	x		x	x	x		475, ±5%	280-1145P84	IRC, CEC (TO)
				x						182	28-1212	IRC, CEC (TO)

REPLACEABLE PARTS LIST  
ACR SERIES

CIRCUIT SYMBOL	ACR MODEL								DESCRIPTION	SORENSEN PART NUMBER	MANUFACTURER, TYPE
	500	1000	2000	3000	5000	7500	10000	15000			
									Resistors (ohms, 1/2W±10% unless noted) (cont'd)		
R20	x	x	x	x	x	x	x	x	100, 2W Variable	29-387	CL, 43-100
R21	x	x	x	x		x	x	x	820, ±5%	280-1145P70	AB, EB
					x				180., ±5%	280-1145P46	AB, EB
R22	x	x	x	x		x	x	x	1.2K, ±5%	280-1145P76	AB, EB
					x				Not used		
R23	x	x	x	x		x	x	x	15K	280-1145P116	AB, EB
					x				Not used		
R24	x	x	x	x		x	x	x	1.2K, ±5%	280-1145P76	AB, EB
					x				680, ±5%	280-1145P67	AB, EB
R25	x	x	x	x	x	x	x	x	1K	280-1145P74	AB, EB
R26	x	x	x	x	x	x	x	x	560	280-1145P65	AB, EB
R27	x	x	x	x	x	x	x	x	560	280-1145P65	AB, EB
R28	x	x	x	x	x	x	x	x	18K	280-1145P119	AB, EB
R29	x	x	x	x	x	x	x	x	68K	280-1145P140	AB, EB
R30	x	x	x	x	x	x	x	x	1K	280-1145P74	AB, EB
R31	x	x	x	x	x	x	x	x	1K	280-1145P74	AB, EB
R32	x	x	x	x	x	x	x	x	4.7K	280-1145P98	AB, EB
R33	x	x	x	x	x	x	x	x	820	280-1145P71	AB, EB
R34	x	x	x	x	x	x	x	x	820, ±5%	280-1145P70	AB, EB
R35	x	x	x	x	x	x	x	x	200, ±5%	280-1145P48	AB, EB
R36	x	x	x	x	x	x	x	x	820	280-1145P71	AB, EB
R37	x	x	x	x	x	x	x	x	4.7K	280-1145P98	AB, EB
R38	x	x	x	x	x	x	x	x	4.7K	280-1145P98	AB, EB
R39	x	x	x	x	x	x	x	x	1.8K	280-1145P83	AB, EB
R40	x	x	x	x					180	280-1145P47	AB, EB
					x	x	x		47	280-1145P26	AB, EB
R41	x	x	x	x					180	280-1145P47	AB, EB
					x	x	x		47	280-1145P26	AB, EB
R42	x	x		x					390, 2W	280-1147P58	AB, HB
			x						510, 1W, ±5%	280-1180P63	AB, GB
					x	x	x		Not used		
R43	x	x							Not used		
			x	x	x				33K, 2W, ±5%	27-343	AB, HB
R44	x	x							Not used		
			x	x	x				33K, 2W, ±5%	27-343	AB, HB
R45	x	x							Not used		
			x	x	x				33K, 2W, ±5%	27-343	AB, HB
						x	x	x	820	280-1145P71	AB, EB
R46	x	x							Not used		
			x	x	x				33K, 2W, ±5%	27-343	AB, HB
						x	x	x	1K	280-1145P174	AB, EB
R47	x	x	x	x	x				Not used		
						x	x	x	10	280-1145P2	AB, EB
R48	x	x	x	x	x				Not used		
						x	x	x	10	280-1145P2	AB, EB
R49	x	x	x	x	x				Not used		
						x	x	x	3.9K	280-1145P95	AB, EB
R50	x	x	x	x	x				Not used		
						x	x	x	470, 1W, ±5%	28-726	WL, GB
R51	x	x	x	x	x				Not used		
						x	x	x	14.7	28-1196	IRC,CEC(T0)
R52	x	x	x	x	x				Not used		
						x	x	x	100, 12.5W	27-590-73	WL
R53	x	x	x	x					39	27-1154	AB, EB
					x				Not used		
R54	x	x	x	x					39	27-1154	AB, EB
				x					Not used		

REPLACEABLE PARTS LIST  
ACR SERIES

CIRCUIT SYMBOL	ACR MODEL								DESCRIPTION	SORENSEN PART NUMBER	MANUFACTURER, TYPE	
	500	1000	2000	3000	5000	7500	10000	15000				
R55	x	x	x	x	x		x	x	x	<u>Resistors (ohms, 1/2W±10% unless noted)</u>  Not used 330	280-1145P56	AB, EB
S1	x	x		x	x	x		x	x	<u>Switches</u>  Input Power DPST Not used	45-112	CH,7561K5
T1	x									<u>Transformers</u>  Auto-transformer Auto-transformer Auto-transformer Auto-transformer Auto-transformer Auto-transformer Auto-transformer Auto-transformer Auto-transformer	126-2565 126-2569 126-2601 126-2604 126-2610 126-2784 126-2772 126-2787	SR SR SR SR SR SR SR SR
T2	x	x	x	x	x					Sync	126-2581	SR
T3	x	x	x	x	x	x	x	x	x	Sync	126-2805	SR
T4	x	x	x	x	x	x	x	x	x	Voltage sensing	126-2564	SR
T5	x	x	x	x	x	x	x	x	x	Current sensing	126-2579	SR
T6	x	x	x	x	x	x	x	x	x	Pulse	126-2632	SR
										Pulse	126-2632	SR
										<u>Miscellaneous</u>		
										<u>Terminal Boards</u>		
TB1	x									Input/output	43-038-2	SR
		x								Input/output	43-064-1	SR
			x							Input/output	42-078	SR
				x						Input/output	43-110	SR
					x					Input/output	90-3051	SR
						x				Input/output	190-3511	SR
							x			Input/output	190-3511	SR
								x		Input/output	190-3522	SR
TB2	x	x								Not used		
			x	x	x	x	x	x		Input/output	42-079	SR

REPLACEABLE PARTS LIST  
ACR SERIES

CIRCUIT SYMBOL	ACR MODEL								DESCRIPTION	SORENSEN PART NUMBER	MANUFACTURER, TYPE
	500	1000	2000	3000	5000	7500	10000	15000			
---	x	x	x	x	x	x	x	x	<u>Miscellaneous (cont'd)</u>  <u>ACR MODEL</u> <u>SCHEMATIC DIAGRAM</u>  ACR 500            D200-3513 ACR 1000        D200-3531 ACR 2000        D200-3533 ACR 3000        D200-3534 ACR 5000        D200-3532 ACR 7500        D200-3796 ACR 10,000      D200-3790 ACR 15,000      D200-3808	<u>CIRCUIT BOARD ASSEMBLY</u>  190-3219 190-3219 190-3219 190-3219 190-3405 190-3507 190-3507 190-3507	

# SERVICE NOTES

# FIELD SERVICE REPRESENTATIVES

## UNITED STATES

### ALABAMA

B & C Instruments, Inc.  
7920 Unit 5, Charlotte Drive  
Huntsville, Alabama 35802  
Tel. (205) 883-6530

### ARIZONA

Arizona Electronic Standards Lab.  
1848 West Campbell  
Phoenix, Arizona 85015  
Tel. (602) 264-9351

### CALIFORNIA

E.P. Specialists  
7052 Orangewood Street  
Suite No. 1  
Garden Grove, California 92641  
Tel. (714) 898-8339

J.D. & Associates  
282 Charcot Avenue  
San Jose, California 95131  
Tel. (408) 435-1010

### ILLINOIS

J.H. Metrology Co., Inc.  
1801 Hicks Road - Unit F  
Rolling Meadows, Illinois 60008

### LOUISIANA

SEA-TRAC Marine  
114 Hickory Ave.  
New Orleans, Louisiana 70123  
Tel. (504) 737-0591

### MARYLAND

Applied Metrology Inc.  
10067 N. 2nd Street  
Laurel, Maryland 20810  
Tel. (301) 953-1010

### MICHIGAN

Comtel Standards Laboratory  
21223 Hilltop Street  
P.O. Box 5034  
Southfield, Michigan 48037  
Tel. (313) 358-2500

### MINNESOTA

Instrumentation Services Inc.  
957 Winnetka Avenue, North  
Minneapolis, Minnesota 55427  
Tel. (612) 544-8916

### MISSOURI

Industrial Service Laboratories  
118 N.W. Business Park Lane  
Riverside Business Park  
Kansas City, Missouri 64150  
Tel. (816) 587-5400

Industrial Service Laboratories  
4354 Olive Street  
St. Louis, Missouri 63108  
Tel. (314) 535-5760

### NEW HAMPSHIRE

Sorensen Company  
676 Island Pond Road  
Manchester, New Hampshire 03103  
Tel. (603) 668-4500

### NEW JERSEY

Ampower Electronic Instrument  
Co. Inc.  
40 Vreeland Street  
Totowa, New Jersey 07512  
Tel. (201) 256-0013

### NEW MEXICO

Instrument Service Laboratories  
680 Haines Avenue N.W.  
Albuquerque, New Mexico 87102  
Tel. (505) 842-1107

### NEW YORK

Mohawk Ltd.  
1 Newell Lane  
Chadwicks, New York 13319  
Tel. (315) 737-7328

### OHIO

Comtel Instrument Company  
5387 Avion Park Drive  
Cleveland, Ohio 44143  
Tel. (216) 442-8080

### TEXAS

Certified Test Equipment  
601 Easy Street  
Garland, Texas 75042  
Tel. (214) 494-3446

### WASHINGTON

XTEK  
14824 Northeast 31st Circle  
Redmond, Washington 98052  
Tel. (206) 885-6969

Radar Marine Electronics  
16 Squalicum Mall  
Bellingham, Washington 98225  
Tel. (206) 733-2012

## WORLDWIDE

### AUSTRALIA

HAWKER PACIFIC Pty., LTD.  
Advanced Products Division  
7 Rachael Close  
Silverwater, N.W.W. 2141

### CANADA

Allan Crawford Associates Ltd.  
5835 Coopers Avenue  
Mississauga, Ontario Canada L4Z 1R9  
Tel. (416) 890-2010

Allan Crawford Associates Ltd.  
1935 30th Avenue N.E. Unit 14  
Calgary, Alberta Canada T2E 6Z5  
Tel. (403) 230-1341

Brunelle Instrument Company  
73 6th Range South  
Industrial Park  
St. Elie D'Orford  
Quebec JOB 2S0  
Tel. (819) 563-9096

### ENGLAND

Cossor Electronics Ltd.  
The Pinnacles, Harlow  
Essex CM19 5BB, England  
Tel. (279) 26862

Hollidyne Electronics Ltd.  
Watermill Industrial Estate  
Aspenden Road  
Buntingford, Hertfordshire  
England SG9 9JS  
Tel. 01-44-0763-7258

### FRANCE

GPL s.a.  
7, rue Henri Gatotot  
92320 Chatillon-sous-Bagneux  
Tel. (1) 746-03-10

### ISRAEL

Agentex Ltd.  
ATIDIM  
Scientific Industries Park  
End of Dvora Hanevia Road  
P.O. Box 10150  
Tel Aviv 61101 Israel  
Tel. 03-493111

### ITALY

3G Electronics S.r.l.  
Via Perugino 9  
20135 Milano, Italy  
Tel. 39-2-54-42-91

### WEST GERMANY/AUSTRIA

Neumuller GmbH  
Eschenstrasse 2  
8028 Taufkirchen/Muenchen  
W. Germany  
Tel. 089/61181

# Sorensen

A Raytheon Company